



## **Drainage and Grease Management for the Commercial Kitchen**

Hygiene**First**



## ACO. creating the future of drainage

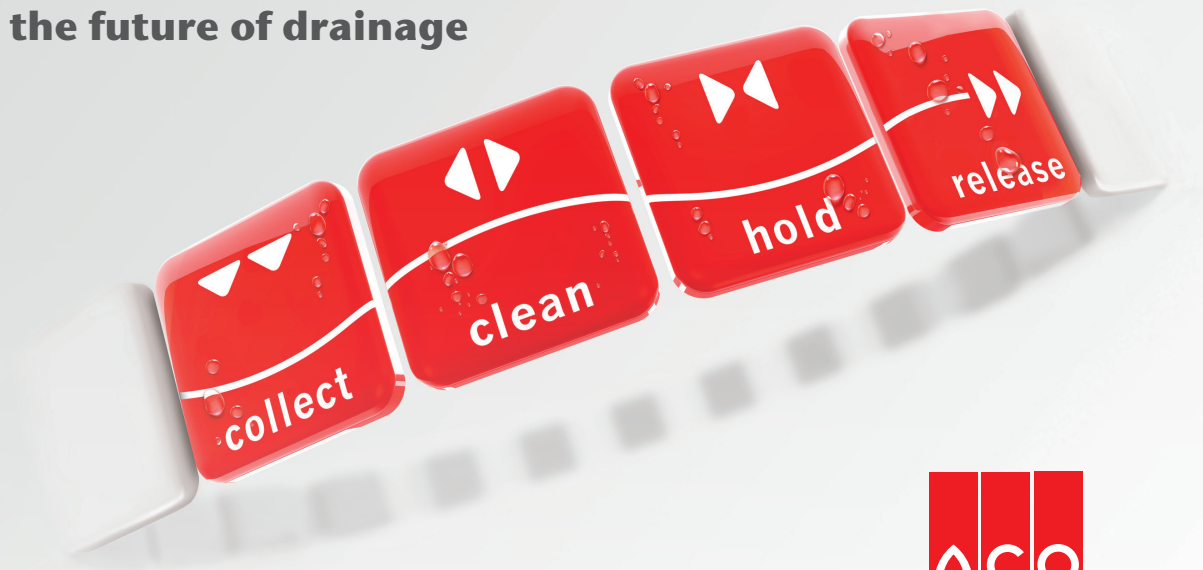

### The ACO system chain provides drainage solutions to meet the needs of tomorrow's food service facilities.

Hostile environments, hot water and grease must be counteracted by more complex and sophisticated drainage concepts. ACO achieves this with intelligent system solutions which address food safety, people and water protection. Every product within the ACO system safely controls the water as it passes along the chain to ensure that it can be hygienically, economically and ecologically handled.



#### **collect:**

The surface water or the liquids being treated are collected as quickly and as completely as possible by the drainage system. This part of the ACO system chain guarantees protection, safety and comfort for the people, buildings and traffic routes in the immediate vicinity.



#### **clean:**

The collected liquids are treated using integrated physical, chemical or biological processes that ensure they can be discharged into public sewers – the minimum requirement. This part of the ACO system chain creates the conditions for recycling and sustainable use.



#### **hold:**

Containers, barriers and valves ensure that liquids stay within the drainage system where they can be properly controlled. This part of the ACO system chain enhances the protection and safety of food, your building and the environment.



#### **release:**

Pumps, lifting plant and pipe systems transfer the collected, treated and controlled water into the downstream systems and processes. This part of the ACO system chain brings the collected, treated and controlled water to the interfaces for further treatment, re-use or release.



## CONTENT

<b>ACO system chain</b>	<b>02</b>
<hr/>	
<b>About ACO</b>	<b>04</b>
<hr/>	
<b>HygieneFirst</b>	<b>06</b>
<hr/>	
<b>Drainage and Grease Management for the Commercial Kitchen</b>	<b>08</b>
<hr/>	
<b>Drainage Management</b>	<b>10</b>
<hr/>	
<b>Grease Management</b>	<b>12</b>
<hr/>	
<b>ACO product overview</b>	<b>16</b>
<hr/>	
<b>ACO service chain</b>	<b>18</b>



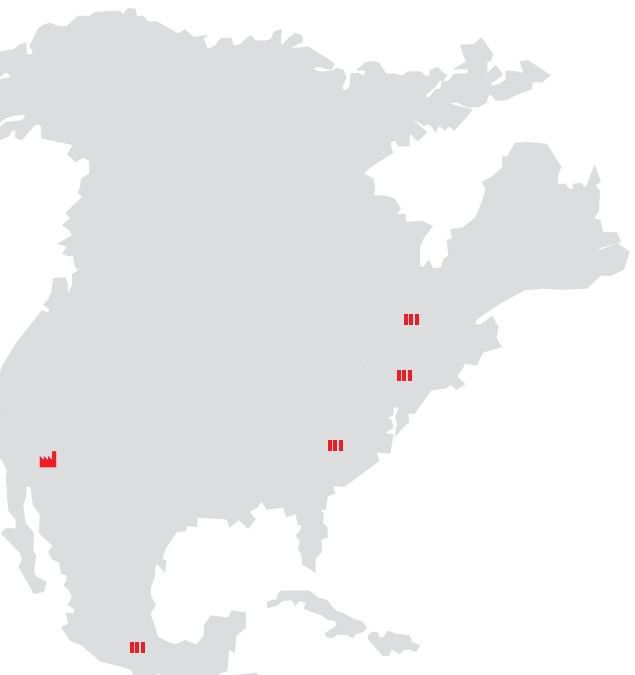

## About ACO

### Who we are

ACO is the established leader in providing drainage systems for the food service industry. Each drainage system is designed to provide maximum reliability, longevity and durability while preventing hygienic issues that can put your facility at risk. More than 60 years of drainage experience makes ACO the world-class supplier of drainage systems.

### What we do

ACO drainage and grease separation systems are designed around the three most important topics for the food service industry: food safety, cost management and health & safety. We design our products to drain processed wastewater hygienically and economically, exceeding the high standards established by the European Hygienic Engineering and Design Group (EHEDG).

### Where we are

With sales offices throughout the world and 29 modern production sites situated throughout all continents, we are fully conversant with international standards and also work extensively with key industry bodies to stay ahead of the head when it comes to creating the most modern systems available.

### Why choose us

We work hand-in-hand with commercial kitchen specialists and designers to create systems suited specifically to their needs. When using ACO drainage systems you can expect optimal top performance, design with emphasis on hygienic performance, and the highest level of confidence that you are using the best drainage system on the market.





## ACO at a glance

- 1946, company founded by Josef-Severin Ahlmann
- 4.200 staff in more than 40 countries
- 30 production sites in 15 countries
- Sales 2017: 775 million €

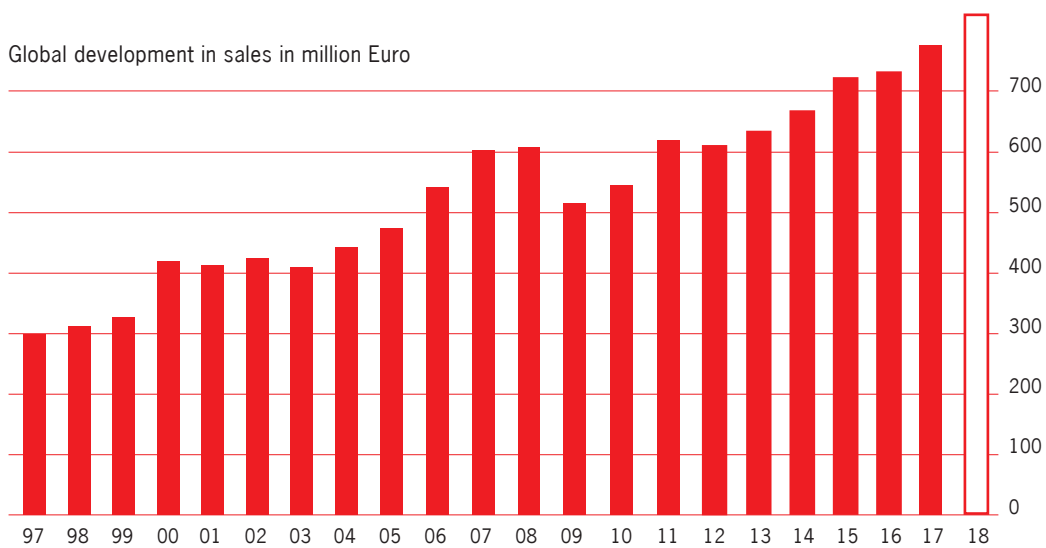

## Hygiene**First**

As one of the world's leading commercial drainage specialists, ACO Group understands the critical role that drainage plays in a successful commercial food preparation business. We appreciate that food safety, hygiene and cost control are all vital factors yet we also understand that for many, drainage is out of sight and therefore out of mind.

As a result, many drainage systems are not designed well. At best this leads to costly on going cleaning and maintenance, and at worst it can result in food contamination, closure of a facility and the loss – or even closure – of business. As the company that's driving the future of drainage, we are determined to change this by raising the profile of hygienic drainage and improving standards across every part of the process.

Our HygieneFirst philosophy represents our commitment to delivering products that provide ultimate hygienic performance. We design intelligent drainage solutions that minimize operational costs without compromising food safety.









## **Drainage & Grease Management for the Commercial Kitchen**

Commercial kitchens are extremely busy environments with potentially wet and greasy floors due to the abundance of liquids used in both the cooking and cleaning processes, and of course, liquids are often very hot! Waste water can also contain fat which is a major cause of pipe blockages and cannot be released to the waste water system. In combination, these factors may affect Food Safety, Operational cost and Health & Safety.

### **Food safety**

Food safety can be severely affected due to poor drainage and grease separation systems. ACO solutions are designed to effectively and safely drain away and handle process water. We design our products specifically to reduce the risk of food contamination.

### **Cost control**

Management of costs is a major factor in business today. Commercial kitchen equipment including drainage and grease separation systems should fulfil its function with low operational cost in mind throughout its entire lifespan. ACO drainage and grease separation systems are designed so they can be easily maintained, reducing associated cleaning costs and maximising hygienic performance.

### **Health & safety**

Minimizing the risk of injury in the workplace is of prime importance to any commercial kitchen facility. It's essential that your facility has a drainage system which improves health and safety conditions during cleaning, emptying and operation, while ensuring hygiene is always front of mind.





## **Drainage Management**

Hygienic standards in the commercial kitchen industry are rising. ACO is meeting these changing demands by incorporating hygienic design principles, industry best practice and the guidelines of bodies including the European Hygienic Engineering and Design Group (EHEDG) into the design of its drainage solutions.

Operational costs are a major factor in business today. Every product and system needs to fulfil its function efficiently throughout its entire lifespan. ACO provides the expertise and quality necessary to provide the perfect balance between high levels of food safety and operational cost.

The kitchen is a potentially hazardous environment because of the ever-present element of heat, liquids and grease. ACO drainage systems are specifically designed to reduce the build-up of liquids by disposing of water and grease effectively and immediately.

### Food safety features of ACO drainage

ACO hygienic drainage fulfils hygienic requirements to prevent harmful bacteria contamination. We apply relevant hygiene design principles reserved for food contact surfaces recommended by EHEDG.

Our product design ensures minimal build-up of food particles and debris as well as a safe connection with the surrounding floor to minimise any opportunity for bacteria to grow throughout the drainage system.

Sleek slope function and hygienically designed products ensure our system is fully drainable eliminating the stagnant odour of waste water.

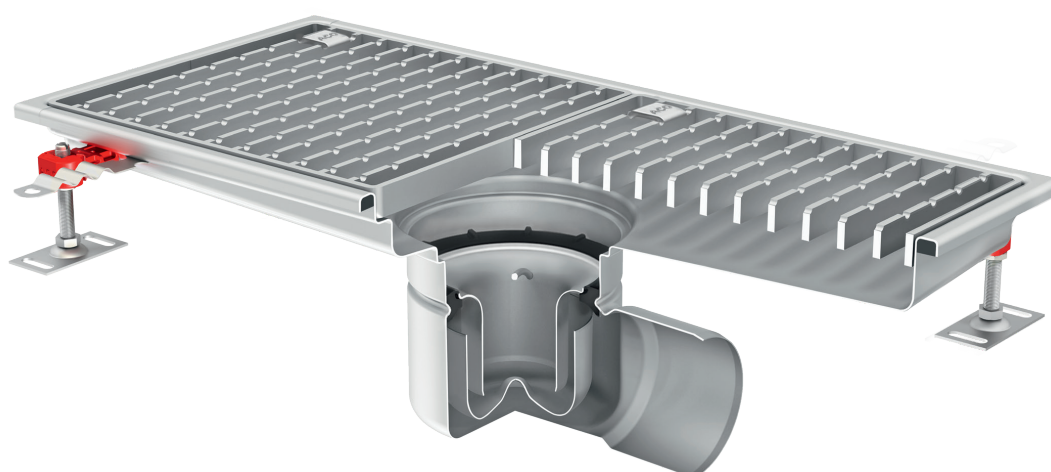
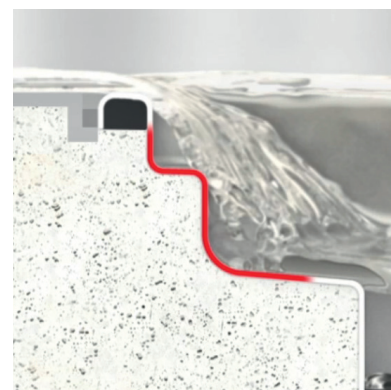
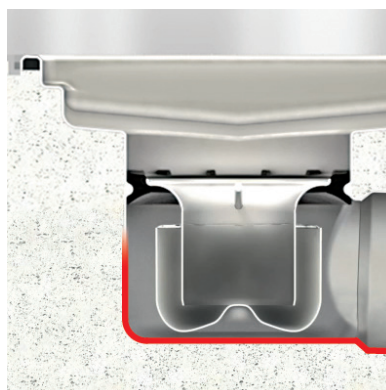

## Cost control features of ACO drainage

ACO drainage system can be easily maintained, reducing associated cleaning costs thanks to their functional design and cleaning recommendations which have been developed in partnership with premium cleaning agent suppliers.

ACO's advanced manufacturing technologies ensure durability and our special surface treatment guarantees corrosion resistance. Our systems perform effectively at all times and keep disruption to a minimum.

We provide expertise in drainage system planning, correct installation and creating a safe connection with the surrounding floor to avoid unnecessary cost.

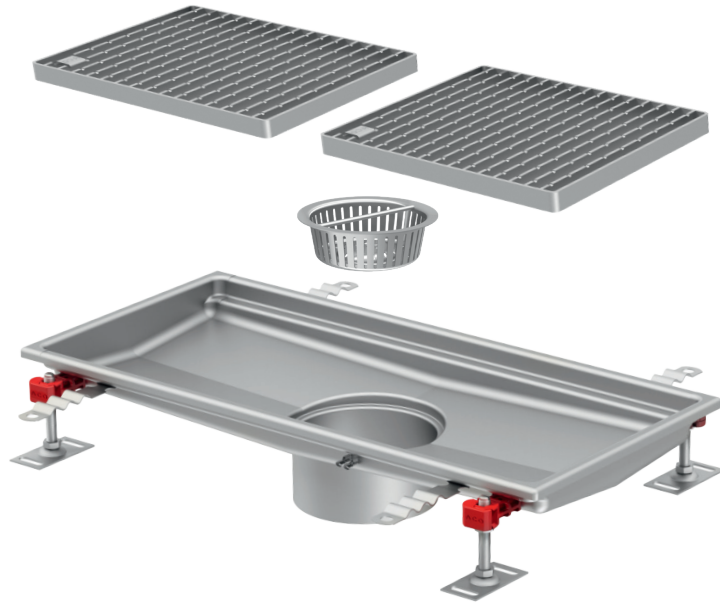

## Health & Safety features of ACO drainage

For additional safety in high risk areas that require heavy water usage is available slip resistant ladder and cast grating.

Each component of the drainage system is easy to remove and clean, and there are no sharp edges for optimum employee safety.

ACO drainage products have a fire resistant solution certified according to EN 136.

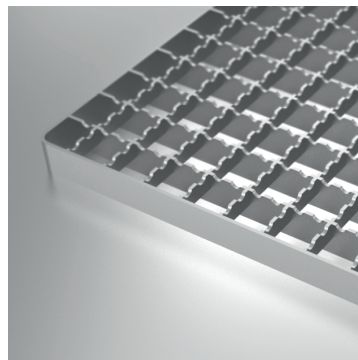
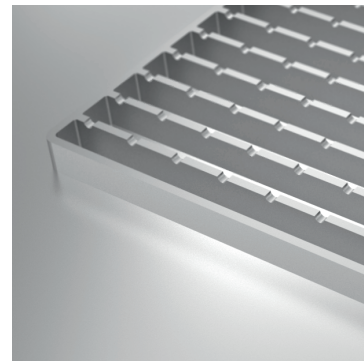
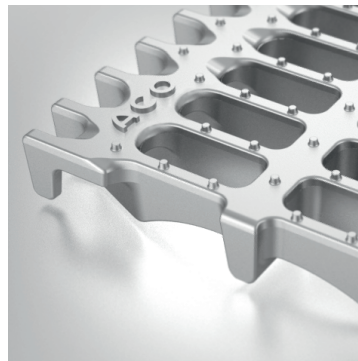



ACO

## **Grease Management**

Commercial kitchens generating waste water must have pre-treatment plants to ensure that solids and liquids that release harmful or unpleasant vapours or interfere with operations are not discharged into the public sewerage network.

In addition to odour reduction, ACO systems also reduce the amount of work required to handle grease disposal and cleaning. For example, if a grease separator features automated cleaning, it is no longer necessary to use external cleaning equipment. The use of the filling device also allows refilling to take place directly at the separator.

Health & Safety is of prime importance in a commercial kitchen operation with particularly attention being paid to process reliability and fire prevention.

### Food safety features of ACO grease separators

System ACO grease separators eliminate unpleasant smells during cleaning and disposal.

Effective hydro mechanical high pressure 360° internal cleaning (175 bar) removes all residue in the separator.

Grease separators are available in stainless steel for optimal hygiene.

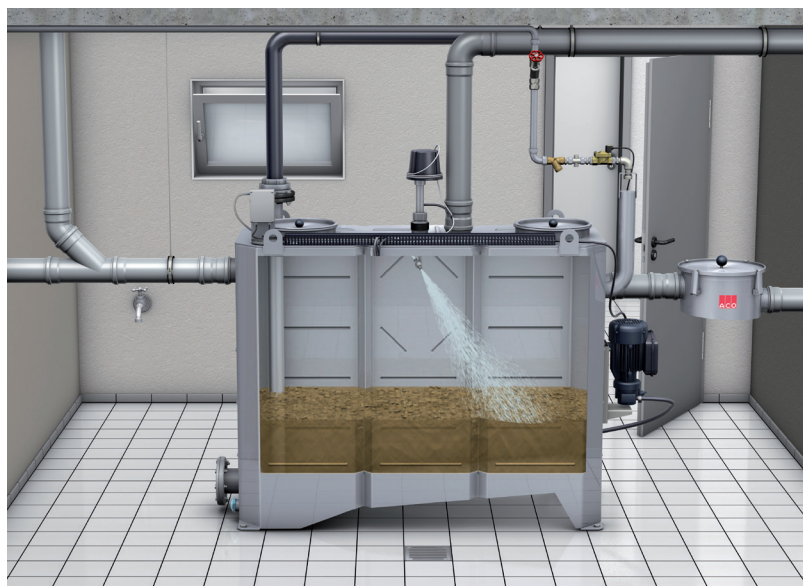

### Cost control features of ACO grease separators

ACO grease separators automatically measure the grease layer, so the operator knows when they need emptying.

Operational flexibility is ensured by our GSM Mobile module. Information about inspections and maintenance needs are sent to mobile phones.

Operational cost are optimised due to automatic cleaning and grease disposal.

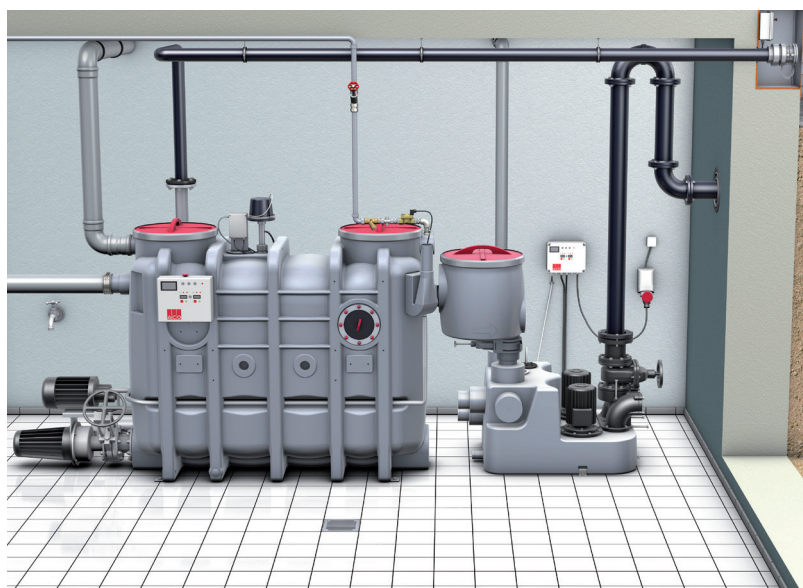



## Health & Safety features of ACO grease separators

Benefiting from automatic cleaning, ACO's grease separator eliminates any health and safety risk during disposal and cleaning.

Sizing, layout and the right solution specification support ensure safe installation and maintenance.

ACO grease separators offer a stainless steel incombustible solution.

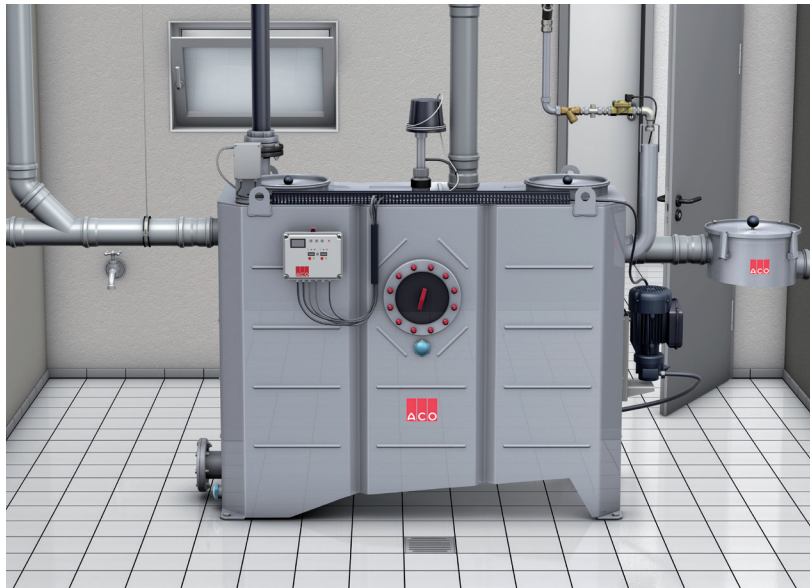

## Commercial Kitchen

There are three principal areas in every commercial kitchen: the storage and preparation area, the production area, and the washing and disposal area. Each area handles different processes in the commercial kitchen environment and has different demands for waste water management. Nevertheless there are some aspects which are common for all three.

### A well-designed drainage system should have:

- A debris filter at outlet
- Easily removable non-slip gratings
- Easily removable foul air trap
- Hygienic design to avoid bacteria traps
- Proper volume capacity size
- A grease separator for removal of fats and grease

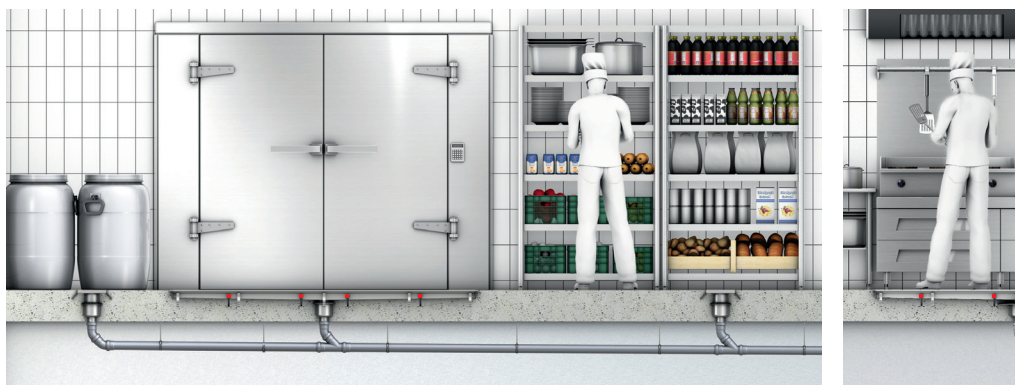

**Storage area**

**Preparation area**

### Drainage Management



ACO hygienic gully



ACO modular box channel

### Grease Management

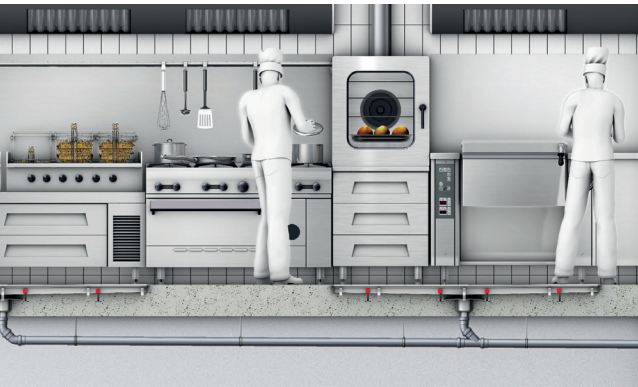

**Production area**

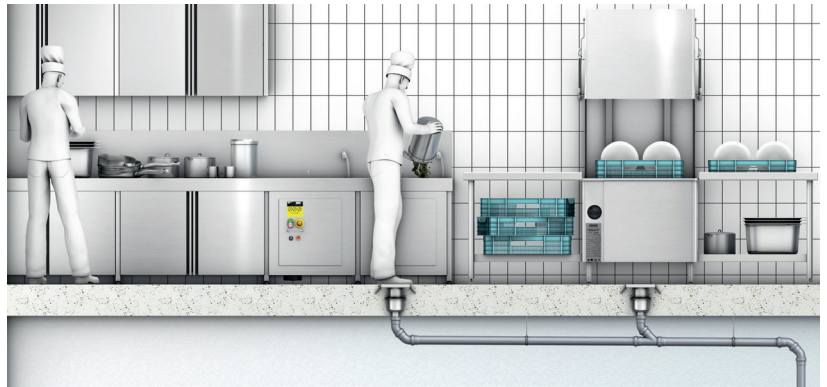

**Washing area**

**Disposal area**

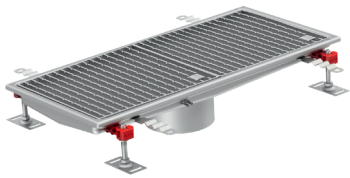

ACO hygienic box channel



ACO modular slot channel



ACO pipe



ACO Lipumax P-DA



ACO Lipurat-RAE

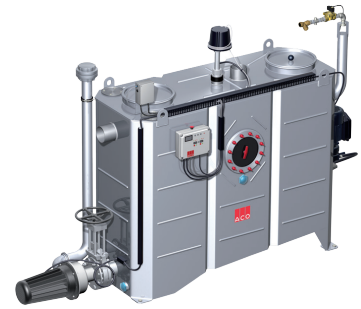

ACO Lipurat-OAE



## Product overview

### ACO hygienic gully

The ACO hygienic gully range incorporates hygienic design principles to ensure the optimum hygienic performance. ACO hygienic gullies are available in three body sizes to cater for different flow rates and construction requirements including shallow construction depths and applications where preventative fire measures are required. ACO hygienic gullies are certified according to EN 1253.



### ACO hygienic box channel

The ACO hygienic box channel range incorporates hygienic principles to ensure the optimum hygienic performance. The hygienic box channel range is ideal for applications where high standards of hygiene are required as they are capable of handling large volumes of fluid. ACO hygienic box channels are certified according to EN 1253.



### ACO modular slot and ACO modular box channels

Our modular range with standardised 20, 125 and 200 mm widths provides a most versatile system with off-the-shelf availability. Accessories such as corner units and a choice of grating make this system perfect for a wide range of applications. Certified to EN 1433, CE marked.



### ACO pipes

The ACO stainless steel push-fit pipe system is designed for grey or black water. ACO pipe offers a product life in excess of 40 years thanks to use of stainless steel. Easy installation and on-site handling is ensured by push-fit assembly. ACO pipe is more hygienic, robust and durable than plastic pipe systems for gravity and vacuum drainage.



### ACO grease separators

A comprehensive range caters for all size requirements within the EN 1825 specification, with performance at or beyond the standard's requirement. Our separators can be specified with varying degrees of sophistication: grease removal and cleaning maintenance can be automated, minimising disruption in busy catering environments. Separators are tested and certified according to EN 1825 and are therefore CE marked.



## The ACO service chain

As the leading manufacturer of drainage solutions, we pride ourselves in being experts in everything relating to drainage. We are always happy to share our comprehensive expertise with our partners on the selling side, as well as architects, planners and the trades. This not only helps us simplify your working day but also enables us to safeguard the quality and the market leadership of ACO solutions.



**train:**

**Information and further education**

We share the global expertise of the ACO Group with dealers, planners, architects and installers who prioritise quality. We invite you to profit from our expertise and attend a number of CPD training sessions organized by us.



**design:**

**Planning and optimisation**

There are many different options when it comes to the specification and design of drainage solutions but which concept produces the most economical, hygienic and safest technical solution? We'll help you find the right answer.



**support:**

**Construction advice and assistance**

We provide you with project-related advice and support to ensure that no unpleasant surprises occur between the planning and realisation of a drainage solution.



**care:**

**Inspection and servicing**

ACO products are designed and built for long service. Our customer care services also ensure that ACO continues to satisfy your high quality requirements year after year.



