

ID22

ACO Industrial Drainage

Product Catalogue



ACO. creating
the future of drainage

The ACO system chain provides drainage solutions which meet the future needs of industries where hygiene is essential



COLLECT:	CLEAN:	HOLD:	RELEASE:
Collect and remove	Pre-clean and process	Protect and attenuate	Pump, discharge and reuse

In a food service environment, hot water, grease and organic waste must be counteracted by more complex and sophisticated drainage concepts. ACO achieves this with intelligent system solutions which optimise food safety, health and safety of employees and the protection of water. Every ACO product within the ACO system chain safely controls water as it passes along the chain to ensure it can be hygienically, economically and ecologically handled in a viable way.



ACO system chain
in action



Introducing ACO Industrial Drainage	■ General introduction	6	1
	■ HygieneFirst	6	
	■ Hygienic design requirements	7	
	■ Hygienic design principles	8	
	■ Material - stainless steel and surface treatment	9	
	■ Standards and Certifications	10	
	■ System overview and benefits	11	
	■ Selection guide	12	
ACO gully	■ Introduction	20	2
	■ ACO hygienic gully 142	22	
	■ ACO hygienic gully 157	36	
	■ ACO hygienic gully 218	58	
	■ ACO hygienic gully 315	78	
	■ ACO hygienic gully 440	79	
	■ ACO gully EG150	80	
	■ Gratings	82	
	■ Accessories	101	
	■ Flow rates and construction heights	107	
ACO channel	■ Introduction	112	3
	■ ACO hygienic box channel	114	
	■ ACO vinyl box channel	122	
	■ ACO frameless ladder grating	126	
	■ ACO hygienic ladder grating	128	
	■ ACO mesh grating	134	
	■ ACO hygienic slot cover	136	
	■ Accessories for ACO box channels	139	
	■ ACO customized box channel	140	
	■ ACO slot channel	146	
	■ ACO customized slot channel	149	
	■ ACO modular box channel 125	158	
	■ Grating for ACO modular box channel 125	164	
	■ Accessories for ACO modular box channel 125	169	
	■ ACO modular box channel 200	170	
	■ Grating for ACO modular box channel 200	178	
	■ Accessories for ACO modular box channel 200	182	
	■ ACO modular slot channel 20	183	
	■ Accessories for ACO modular slot channel 20	189	
	■ ACO design channel	191	
■ Flow rates and Construction heights	192		
ACO pipe	■ Introduction	198	4
	■ Straight pipes	200	
	■ Fittings	207	
	■ Flow rates	232	
	■ Operating pressures	234	
ACO Industrial Drainage Support	■ Transport & handling	238	5
	■ ACO fire protective solution	240	
	■ Cleaning procedures	244	
	■ Typical installation examples	250	
	■ Material	266	



1

Introducing ACO Industrial Drainage

Introducing ACO Industrial Drainage

General introduction	Introduction – product portfolio and application	6
	Hygiene First	6
Hygienic design requirements	Introduction – services and product certifications	7
	Hygienic Design	7
	Material	7
Hygienic design principles	Hygienic Design	8
	Material – stainless steel and surface treatment	9
Standards and certifications	ACO gully and ACO channel	10
	ACO pipe	10
System overview and benefits	Food safety	11
	Cost control	11
	Health & Safety	11
	Application	12
	Drainage Type	13
	Material resistance	13
	Floor structure and finish	14
Selection guide	Retention capacity	15
	Channel geometry	15
	Flow rates	16
	Gratings selection guide	16
	Different load class standards	17



Discover more about our products:
buildingdrainage.aco/home

ACO Industrial Drainage
online information



General introduction

1

ACO is one of the World's leading drainage specialists with 60 years' experience gained across a wide range of sectors. Our passion for producing high performance products has led us to make major investments in research and development.

We are working in partnership with commercial facility owners, managers and operators. We are continuously developing our products and enhancing our expertise. We understand the critical role that drainage plays in a successful business.

Our product portfolio includes items which are fully compliant with the highest hygienic requirements. We also have a full understanding of the food industry's own standards such as HACCP and we work with bodies including the European Hygienic Engineering and Design Group (EHEDG).

ACO drainage is used in applications anywhere where hygienic, corrosion resistant and durable drainage performance is essential:

- Professional kitchens
- Food processing facilities
- Brewing, bottling and canning plants
- Chilled warehouses
- Laboratories
- Chemical industries
- Pharmaceutical industries
- Restaurants
- Schools
- Hospitals
- Hotels
- and others



Hygiene**First**

As one of the World's leading commercial drainage specialists, The ACO Group understands the critical role that drainage plays in a successful commercial food preparation business.

We appreciate that food safety, hygiene and cost control are all vital factors, yet we also understand that for many, drainage is out of sight and out of mind.

As a result, many drainage systems are not designed well, which leads to inefficiencies, costly on going cleaning and maintenance. In worst case scenario it can result in food contamination, closure of a facility and even loss of a business. As the company that's driving the future of drainage, we are determined to change this by raising the profile of hygienic drainage and improving standards across every part of the process.

Our HygieneFirst philosophy represents our commitment to delivering products that provide ultimate hygienic performance. We design intelligent drainage solutions that minimize operational costs without compromising food safety.

Hygienic design requirements

ACO offers sustainable, integrated drainage systems which are designed to protect business, the environment and ultimately public health.

Our aim is to constantly improve every aspect of safety, hygiene and functional performance.

We believe that our systems and services are truly unique, delivering unparalleled benefits to everyone involved in project delivery or subsequent operation.

NSF International

ACO has become the first and only drainage company to obtain 14159-1 – Hygiene Requirements for the Design of Meat and Poultry Processing Equipment certification for its products from NSF International.

The certification has been awarded to ACO in recognition of the hygienic performance of its drainage systems and products, and its compliance with the strict standards and procedures of the NSF.

It also underlines ACO's ongoing commitment to the very high standards of manufacturing and to research-led product development which ensures its products deliver optimum hygienic performance.

EHEDG

ACO hygienic drainage fulfils stringent hygienic requirements to prevent harmful bacteria contamination. We apply relevant hygienic design principles that are reserved for food contact surfaces EN 1672, EN ISO 14159 and EHEDG documents No. 8, 13 and 44 to the design of our drainage products.



Hygienic design

Full drainability

The outlet is in lowest position.

Sleek slope functionality provides a fully drainable solution.

Round internal corners

Minimum radius of internal corners is 3 mm.

Hygienic joints

Butt welds are fully welded.

Metal-to-metal contact at non-disassembled joints is avoided.

Sealed joints are designed to prevent accumulation of soil and bacteria.

Edge in-fill

The channel frame edge is filled with a waterproof material.

Material

Stainless steel grade min. 1.4301 according to EN 10088 (304 according to AISI).

Fully pickled and passivated or electropolished.

Hygienic design principles

Hygienic design

1

All internal radii equal or larger than 3 mm which greatly increases cleaning effectiveness

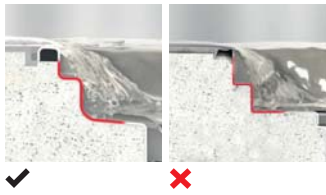

Hygienic joints: deep-drawn body ensures smooth contours eliminating crevices that can harbour dangerous bacteria

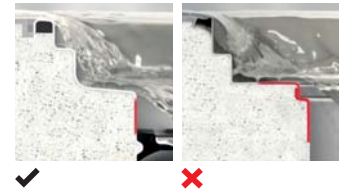

Dry sump design, completely drainable - eliminating stagnant water, smells, microbial growth and potential chemical hazards.

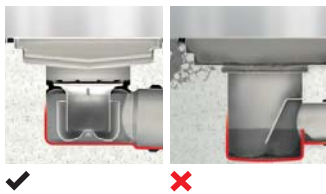

Edge in-fill ensures stable and durable transmission between the gully and surrounding floor and helps to minimise the risk of floor cracks which could harbour microorganism



Cleaning performance



Material

Stainless steel

Stainless steel is the name given to a wide range of steels which have the characteristics of greatly enhanced corrosion resistance over conventional mild and low alloy steels. The enhanced corrosion resistance of stainless steel essentially comes from the addition of at least 11% of chromium, however, most commonly used stainless steels contain around 18% of chromium. Other significant alloying elements include nickel and for superior corrosion resistant properties, molybdenum.

Stainless steel has the following unique advantages:

- High corrosion resistance
- Nonporous, easy to clean and disinfect
- Aesthetically pleasing
- Resistant to extreme temperatures and thermal shock
- Coefficient of linear expansion similar to concrete
- 100% recyclable material

ACO drainage is manufactured from austenitic stainless steel, grades 1.4301 or 1.4404 according to EN 10088 (304 or 316L according to AISI).

It is ideal for applications including food processing, leisure, dairy, brewing, pharmaceutical, chemical and petrochemical industries.

Surface treatment

The process cutting, forming and welding of stainless steel will introduce impurities into the surface of the material and unless the appropriate action is taken, the material will begin to corrode and ultimately fail in service. Therefore, after fabrication, it is vital that stainless steel is treated with the correct surface treatment to ensure it is fully corrosion resistant. By applying pickle passivation as the primary surface treatment, the corrosion resistance of stainless steel can be fully restored to its original state, ensuring long and reliable life performance together with the required aesthetic appearance.

Finishes used by ACO include:

Pickle passivation (acid treatment)

All ACO drainage is pickle passivated by immersing products in a series of acid baths. This is a fundamental requirement for removing iron embedded particulates introduced in the fabrication process and also for restoring the chromium depleted regions generated by the welding process.

ACO has one of the largest and most advanced pickle passivation installations in Europe which ensures the optimum corrosion resistance of our products.

Electropolishing (electrochemical process)

After pickle passivation, some products are then immersed in an electrolytic fluid in which the products become the anode of a direct current electrical circuit. This process is characterized by a selective attack of the surface of the components whereby upstanding roughness is preferentially dissolved and will yield a progressively smoother, brighter surface. All hygienic box channel grates are electropolished as a standard.

Brushing (mechanical process)

ACO channels have a brushed upper edge for aesthetic reasons.

Standards and certifications

1

ACO gully and ACO channel

ACO gully and ACO channel ranges are designed, manufactured, tested and certified in accordance with EN 1253. Furthermore ACO modular channels are also certified in accordance with EN 1433 and they are CE marked.

We apply the relevant hygienic design principles reserved for food contact surfaces EN 1672, EN ISO 14159 and EHEDG documents No. 8, 13, 44 and NSF International.

ACO fire protective kit is tested according to EN 1366-2 (Fire resistance tests for service installations) and classified according to EN 13501 (Fire classification of construction products and building elements).

ACO pipe

The ACO pipe push-fit system is classified and certified as non-combustible product and is manufactured in compliance with EN 1124. This standard classifies the ACO pipe systems as class A1 fire resistant (highest rating).

ACO pipe systems are certified also by SITAC authority as fire resistant (cert. no. 0410-01).

Special certificate of fire resistance for coated pipes (no. CSI PK-13-083) is available.

System overview and benefits

ACO provides solutions which optimise food safety, employee's health and safety and water protection. Every ACO product safely controls the water to ensure that it can be hygienically, economically and ecologically managed in a viable way.



Food safety

- ACO hygienic drainage fulfills hygienic requirements to prevent harmful bacteria contamination. We apply relevant hygienic design principles reserved for food contact surfaces as recommended by EHEDG.
- Our product design ensures minimal build-up of food particles and debris as well as a safe connection with the surrounding floor to minimise any opportunity for bacteria to grow throughout the drainage system.
- Sleek slope function and hygienically designed products ensure our system is fully drainable, eliminating the stagnant odour of waste water.

Cost control

- ACO drainage systems can be easily maintained, reducing associated cleaning costs, thanks to their functional design and cleaning recommendations which have been developed in partnership with premium cleaning agent suppliers.
- ACO's advanced manufacturing technologies ensure durability and our special surface treatment guarantees corrosion resistance. Our systems perform effectively at all times and keep business disruption to a minimum.
- We provide expertise in drainage system planning, correct installation and creating a safe connection with the surrounding floor to avoid unnecessary costs.

Health & Safety

- For additional safety in high risk areas that require heavy water usage, a slip resistant grating is available.
- Each component of the drainage system is easy to remove and clean, and there are no sharp edges for optimum employee safety.
- ACO drainage products have a fire resistant solution certified according to EN 136.

Selection guide

Application

1

The layout of the drainage system as well as the design of drainage elements has an impact on future operational effectiveness and on costs.

This guide offers a range of basic areas which need to be considered when specifying a drainage system.

To specify an appropriate drainage system for a particular application, the zone of operation and amount and frequency of water used is crucial.

Production process/ Cleaning process	Zones with high risk for food safety	Zones with medium or low risk for food safety	Zones without direct risk for food safety
Wet production process/ Wet cleaning process	■ Hygienic design - one piece solution without connections; ladder or cast gratings or slot covers	■ Hygienic design - connections and mesh gratings could be considered if cleaning and sanitation procedures allow	■ Hygienic design - recommended for easy cleaning and maintenance. A combination of products could be considered for easy layout design
	■ High retention - high flow rate	■ High retention - high flow rate	■ High retention - high flow rate
	■ Slip resistance - high requirement	■ Slip resistance - high requirement	■ Slip resistance - high requirement
Dry production process/ Wet cleaning process	■ Hygienic design - one piece solution without connections; ladder or cast gratings or slot covers	■ Hygienic design - connections and mesh gratings could be considered if cleaning and sanitation procedures allow	■ Hygienic design is recommended for easy cleaning and maintenance; combination of products could be considered for easy layout design
	■ High flow rate	■ High flow rate	■ High flow rate
	■ Slip resistance - medium requirement	■ Slip resistance - medium requirement	■ Slip resistance - medium requirement
Dry production process/ Controlled wet cleaning process	■ Hygienic design - one piece solution without connections; ladder or cast gratings or slot covers	■ Hygienic design - connections and mesh gratings could be considered if cleaning and sanitation procedures allow	■ Hygienic design - recommended for easy cleaning and maintenance. A combination of products could be considered for easy layout design
	■ Medium to low flow rate	■ Medium to low flow rate	■ Medium to low flow rate
	■ Odour proof cover	■ Odour proof cover	■ Odour proof cover

Drainage type

Based on the basic application, the type of drainage needs to be selected according to the layout of the operational space and technology employed.

Point drainage



Linear drainage



Material resistance

The chemical mixture of the waste water from the process and/or from the cleaning as well as temperature of the final mixture influences the material resistance of the drainage system.

ACO drainage is manufactured from austenitic stainless steel; grades 1.4301 or 1.4404 according to EN 10088 (304 or 316L according to AISI) and is ideal for applications within food processing, dairy, brewery, commercial kitchen, pharmaceutical, chemical, petrochemical industries and leisure.

Besides stainless steel, drainage products also contain sealing materials:

ACO gullies – all the seals are made of NBR (acryl nitrile-butadiene rubber)

or SBR (styrene-butadiene rubber)

ACO box and slot channels – flange connection seals are made of NBR (acryl nitrile-butadiene rubber)

ACO modular box and slot channels – flange connection seals are made of NBR (acryl nitrile-butadiene rubber)

ACO pipes – socket seals can be made from either EPDM (ethylene propylene diene monomer) or FPM (fluoroelastomer) – Viton®.







For details of material resistance see page 254 or contact our Sales/Technical department.

Floor structure and finish

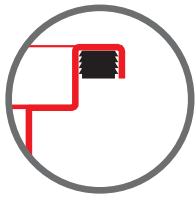
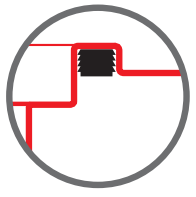
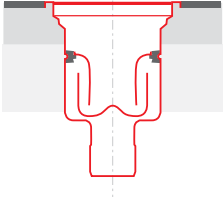
Depending on the composition of the floor construction; the appropriate type of gully or channel should be selected.

If there is insulation in the floor structure, the O-ring needs to be removed from the friction ring, which will allow the water from the insulation to be drained to the gully body.

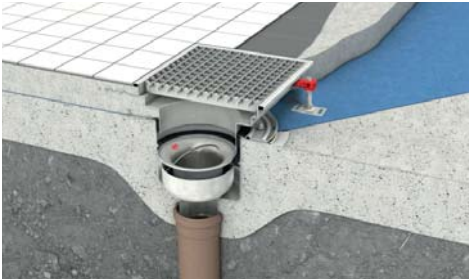
Depending on the floor finish; the appropriate edge of the channel or gully top should be selected.

	Channels + Telescopic gullies			Fixed height gully
Floor finish	Tiled, concrete or resin floor	Vinyl	Tiled, thin bed installation	Tiled, concrete or resin floor
Channel or gully edge	Standard edge	Vinyl edge	Extended edge	Standard edge
Channel or gully top drawing				
Waterproof membrane connection	Connected to gully body		Connected to channel / gully top	Independent of the gully
Gully body type	Telescopic adjustable Adhesive bonding flange or mechanical clamping flange		Telescopic adjustable Location flange	Fixed height gully
Gully body picture				
Installation example				

Retention capacity

Depending on the application, the appropriate retention capacity should be considered.

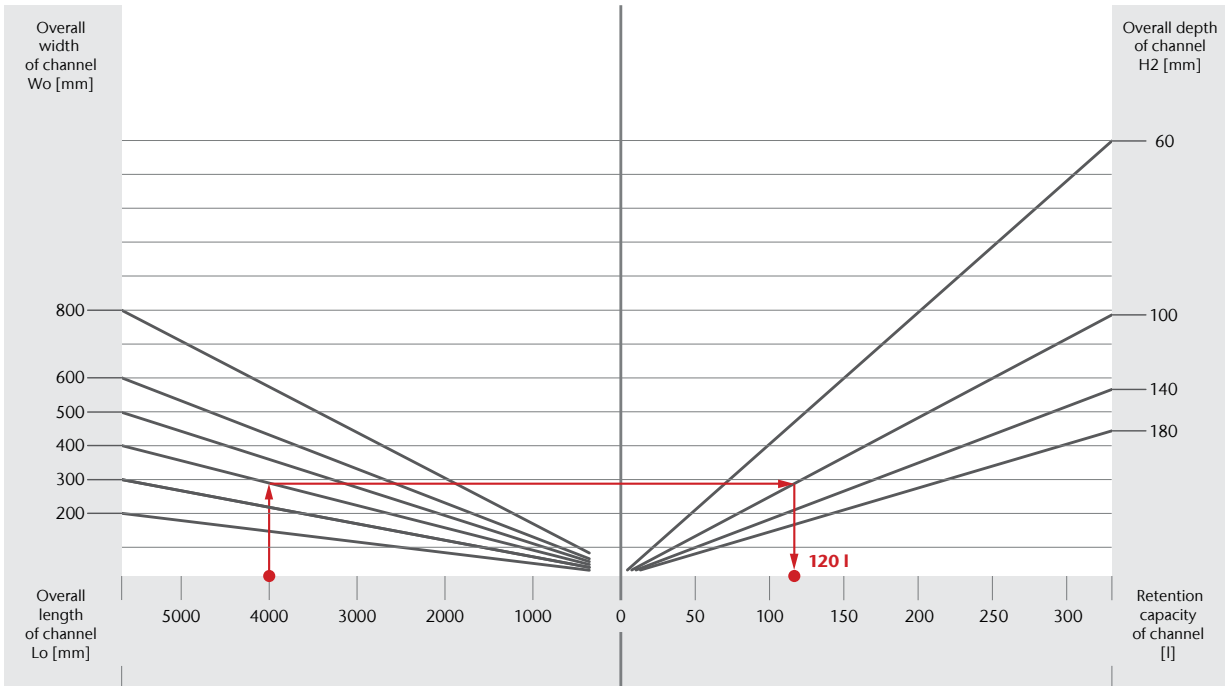

Example: channel length 4000mm, width 400mm, depth 100mm, retention capacity 120 l.

Channel geometry

Based on the retention capacity considered, as well as the floor structure, the particular dimensions of a channel

or gully top (for telescopic solution) need to be specified. For the channel a construction height at the outlet

position as well as the position of the outlet and the height of the endcaps has to be defined.

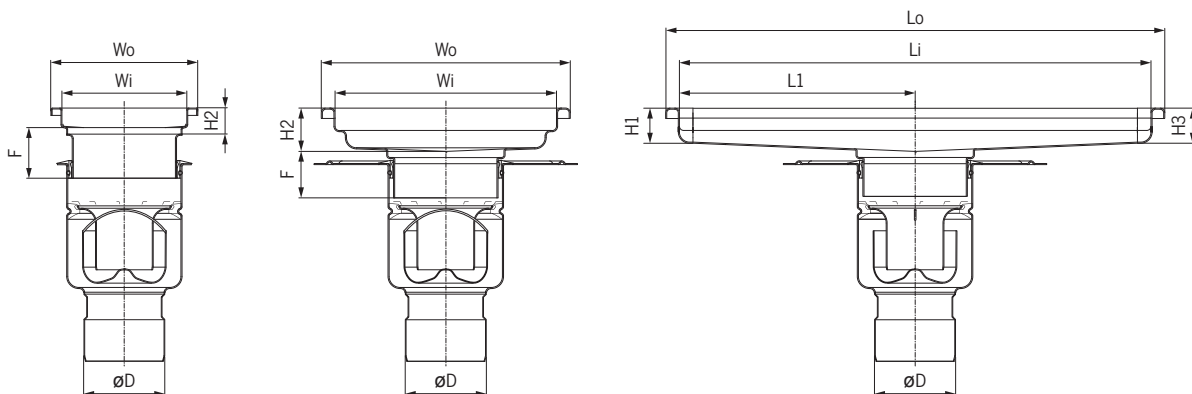

Flow rates

Flow rates reflect the system's ability to constantly drain a certain amount of water.

Flow rate is generally defined by the ACO gully size.

For details of flow rates see page 107 or contact our Sales/Technical department.

Accessories

For the collection of solid parts, the gully or channel should be fitted with a silt basket.

Telescopic connection without flange for waterproofing

Telescopic connection with flange for waterproofing

ACO gully EG150

ACO hygienic gully 142

ACO hygienic gully 157

ACO hygienic gully 218

Accessories delivered as standard with the gully

- Friction ring
- Friction ring; FAT; FAT support

Optional accessories

- | | | | |
|--|--|--|--|
| <ul style="list-style-type: none"> ■ Sieve ■ FAT with silt basket ■ FAT | <ul style="list-style-type: none"> ■ Silt basket for fixed height gully 0.3 l ■ Silt basket for telescopic gully 0.4 l | <ul style="list-style-type: none"> ■ Silt basket for vertical gully 0.6 l ■ Silt basket for horizontal gully 0.3 l | <ul style="list-style-type: none"> ■ Silt basket for vertical gully 1.4 l ■ Silt basket for horizontal gully 0.7 l |
|--|--|--|--|

Gratings selection guide

When selecting the correct grating for your application, careful attention must be given to number of factors. The most important challenge is selecting the right type of grating with appropriate load class. Careful consideration of this will positively influence the grating lifespan.

The correct grating type and load class

The grating itself is the most exposed part of gully or channel in regards to traffic. To minimize the risk of failures, a proper grating type and load class have to be considered based on the defined traffic during all future operations.

■ Type of machinery

Depending on the type of production facility, usually there is a wide range of traffic machinery that will pass over the drainage. Forklifts with pneumatic tires and trolleys with small plastic wheels both behave differently when moving over the same type of grating.

■ Unusual traffic

In occasional situations, machinery that hasn't been considered during grating specification may

enter the area where the drainage is installed. This can include heavy trucks used for cleaning or disposal of waste. Even though this will happen rarely, it presents a great risk of damaging the gratings in just this one instance.

■ Traffic frequency

Wide range of ACO gratings and covers offers a great selection base for both light and heavy load requirements. Consider all grating types and combinations for the most comfortable use.

■ Drainage location

In real life scenario, the traffic movement can be irregular, causing sudden impacts or torque generated by wheels turning on the grating itself. This dynamic load stress can mount up to 2 times the static load value.







Different load class standards

ACO gullies and ACO channels are tested and specified in accordance with EN 1253 norm and the ACO modular channels are tested and specified in accordance with EN 1433 norm.

The testing method for the two norms is different; therefore the values are not directly comparable.

To assist with evaluating and comparing the two different load standards, the table below provides a simple comparison between the EN 1253 and EN 1433 load class specifications.

Traffic type		Recommended load class*		Description
		EN 1253	EN 1433	
Pedestrian		L 15	A 15	Pedestrian areas, change rooms, toilets and areas inaccessible to vehicular machinery
Light Duty		R 50	B 125	Light commercial and industrial areas accessible to solid tyres
Medium Duty		M 125	C 250	Commercial and industrial areas accessible to vehicular traffic, such as machinery with solid tires and pallet jacks
Heavy Duty		N 250		
Extra Heavy Duty		P 400	D 400	Commercial and industrial areas subjected to heavy traffic

* The EN 1433 and EN 1253 load class specification norms for each type of traffic correspond with results acquired under laboratory testing.

Other grating features to consider during selection are hygienic performance, chemical resistance, flow rate and slip resistance.

All of these are necessary to choose the appropriate grating that will last for a long time without any defects.

The table below provides an overview of available gratings and their properties.

ACO grating type	ACO frameless ladder grating	ACO ladder grating	ACO slot cover	ACO mesh grating		
	Slip resistant	Slip resistant	Plain	Slip resistant	Plain	
Surface	electropolished	electropolished	electropolished	sand blasted top	electropolished	electropolished
Slip resistance	Yes	Yes	No	Yes	Yes	No
Cleanability	Excelent	Good	Good	Good	Sufficient	Sufficient
Potential for slip - Pendulum test BS 7976-2	Low	Low	Moderate	Low	Low	Moderate
Slip resistance classification - Ramp test DIN 51130	R11	R11	R9	R11	R11	R9
Load class availability acc. EN 1253 for hygienic channels	M 125	R 50; M 125; N 250; P 400*	R 50; M 125; N 250; P 400*	R 50; M 125; N 250	L 15	L 15
Load class availability acc. EN 1253 for hygienic gullies	M 125	R 50; M 125	N 250	R 50; M 125	L 15	L 15

* P 400 load class available as customised solution only



2 ACO
Gully

COLLECT:
Collect and remove



ACO Gully

Introduction	Hygienic design	20
	System overview	21
ACO hygienic gully 142	Fixed height, vertical outlet	22
	Fixed height, horizontal outlet	24
	Telescopic, vertical outlet	26
	Telescopic, horizontal outlet	29
	Gully top, telescopic	32
	Raising piece, telescopic	35
ACO hygienic gully 157	Fixed height, vertical outlet	36
	Fixed height, horizontal outlet	41
	Telescopic, vertical outlet	46
	Telescopic, horizontal outlet	49
	Gully top, telescopic	52
	Raising piece, telescopic	55
ACO hygienic gully 218	Fixed height, vertical outlet	58
	Fixed height, horizontal outlet	64
	Telescopic, vertical outlet	69
	Telescopic, horizontal outlet	72
ACO hygienic gully 315	Gully top, telescopic	74
	Raising piece, telescopic	77
ACO hygienic gully 440	Fixed height, vertical outlet	78
ACO gully EG150	Fixed height, vertical outlet	79
	Telescopic, vertical outlet	80
Gratings	Telescopic, horizontal outlet	81
	Gratings for gully top 200 x 200	82
	Gratings for gully top ø 230 mm	86
	Gratings for gully top 250 x 250	88
	Gratings for gully top 300 x 300	92
	Gratings for gully top ø 300 mm	96
	Gratings for vinyl top Ø170	98
	Gratings for vinyl top Ø222	99
	Grating for ACO hygienic gully 315	100
	rating for ACO hygienic gully 315	100
Accessories	Accessories for ACO hygienic gully 142	101
	Accessories for ACO hygienic gully 157	102
	Accessories for ACO hygienic gully 218	104
	Accessories for ACO hygienic gully 315	105
	Accessories for ACO hygienic gully 440	105
	Accessories for ACO gully EG150	106
	ACO tundish portable	106
Flow rates and construction heights	Flow rates and construction heights for ACO hygienic gully	107



Discover more in a 3D environment:
buildingdrainage.aco/products

ACO gully
 online information



Introduction

Hygienic design

ACO hygienic drainage fulfils strongest hygienic requirements to prevent harmful bacterial contamination.

We apply the relevant hygienic design principles reserved for food processing equipment EN 1672, EN ISO 14159, EHEDG document No. 8, 13, 44.

ACO gully hygienic features:

- Full drainability
- Internal radii equal or larger than 3 mm
- Hygienic joints
- Edge infill
- Stainless steel grade min. 1.4301 according to EN 10088 (304 according to AISI)
- Fully pickled and passivated

2

Hygienic slip resistant gratings

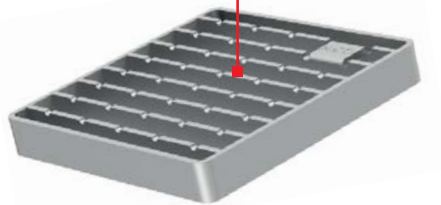

All internal radii equal or larger than 3 mm which greatly increases cleaning effectiveness

Hygienic joints: deep-drawn body ensures smooth contours eliminating crevices that can harbour dangerous bacteria

Full drainability: Dry sump design, completely drainable - eliminating stagnant water, smells, microbial growth and potential chemical hazards.

Edge in-fill ensures stable and durable transmission between the gully and surrounding floor and helps to minimize risk of floor cracks which could harbour microorganism

Foul air trap without overlapped joints

Foul air trap internal corners smooth and rounded

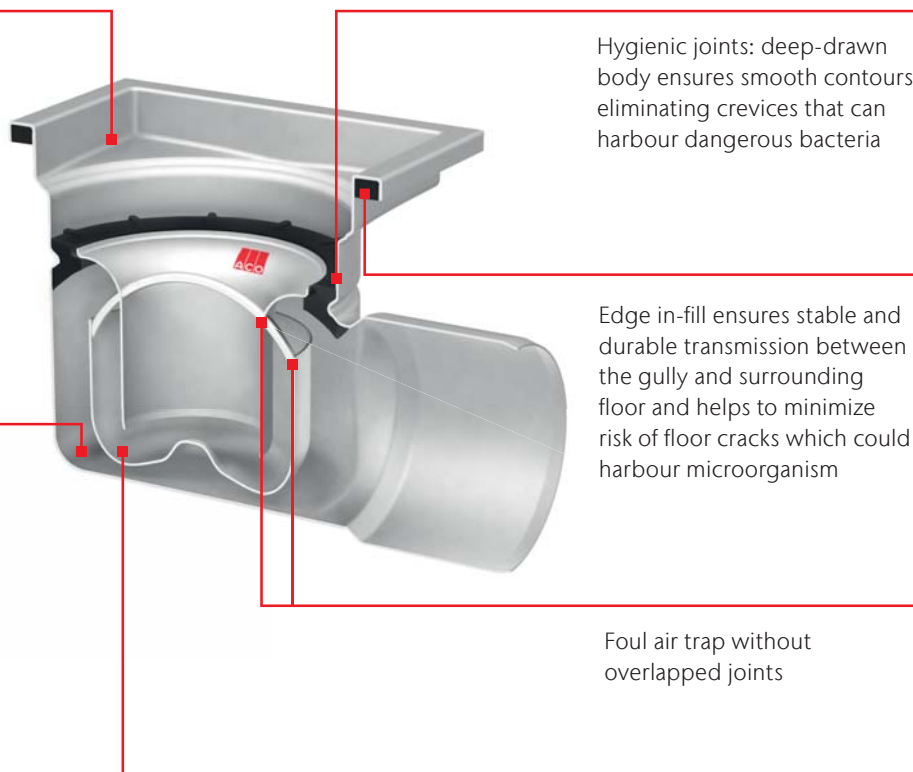

System Overview

ACO gully range is available in a number of versions featuring different flow rates, grating designs, sizes and spigot outlet diameters to suit various applications.

The floor construction and depth together with the use of any waterproofing membrane play an important role in the selection of the appropriate type of gully.

The ACO gully range is available with vertical or horizontal spigot outlets.

Fixed height gullies are convenient and free-standing units which are suitable for cementitious, resin or tiled floors.

Telescopic gullies can be installed either with a gully top or ACO channel in most flooring constructions, including floors with waterproofing membranes.

Fixed height solution



Telescopic solution



- 1** Gratings
- 2** Silt basket
- 3** Foul air trap
- 4** Foul air trap support
- 5** ACO gully body
- 6** Gully top
- 7** Friction ring
- 8** ACO EasyFix levelling feet

ACO hygienic gully 142 fixed height, vertical outlet

Product information

Fixed height gully can be specified as a point drainage in areas where waterproofing is independent of the gully body.

Those gullies can be combined with different grates depending on requested load class.

Product benefits

- Hygienic design following EN 1672, EN ISO 14159 and EHEDG document No. 8, 13 and 44
- Fully pickled and passivated
- Fully removable and easily cleanable stainless steel foul air trap (FAT)
- Protective cover available. See page 264 for more details
- Tested and certified according to EN 1253
- Fire tested and certified solution available for classes EI 90 – EI 180 (EN 13 501-2)
- Wide range of gratings for load class L 15, R 50, M 125 or N 250 (EN 1253) including slip resistant solution
- Adjustable EasyFix levelling feet



Order information

	Top size [mm]	Outlet diameter ø [mm]	Foul air trap	Flow rate EN-1253-1 / Direct [l/s]	Material	Item number
	200 x 200	75	Without FAT	N/A	1.4301	414700
					1.4404	414800
	200 x 200	75	With FAT	1,45 / 2,1	1.4301	414701
					1.4404	414801

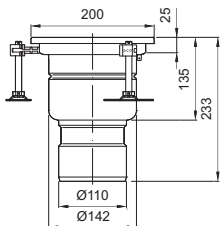
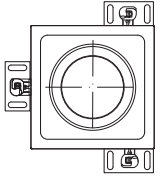
	Top size [mm]	Outlet diameter ø [mm]	Foul air trap	Flow rate EN-1253-1 / Direct [l/s]	Material	Item number	
 	200 x 200	110	Without FAT	N/A	1.4301	414702	
					1.4404	414802	
				With FAT	1,45 / 2,1	1.4301	414703
						1.4404	414803

Extended edge

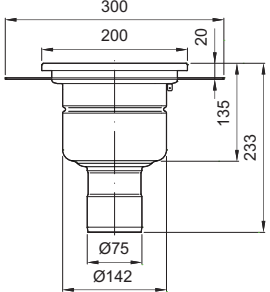
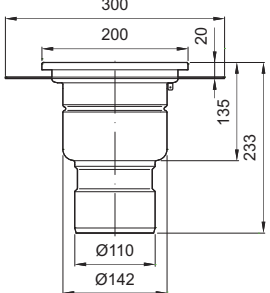
	200 x 200	75	With FAT	1,45 / 2,1	1.4301	414744
					1.4404	414844
	200 x 200	110	With FAT	1,45 / 2,1	1.4301	414745
					1.4404	414845

2

ACO hygienic gully 142 fixed height, horizontal outlet

Product information

Fixed height gully can be specified as a point drainage in areas where waterproofing is independent of the gully body.

Those gullies can be combined with different grates depending on requested load class.

Product benefits

- Hygienic design following EN 1672, EN ISO 14159 and EHEDG document No. 8, 13 and 44
- Fully pickled and passivated
- Fully removable and easily cleanable stainless steel foul air trap (FAT)
- Protective cover available. See page 264 for more details
- Tested and certified according to EN 1253
- Wide range of gratings for load class L 15, R 50, M 125 or N 250 (EN 1253) including slip resistant solution
- Adjustable EasyFix levelling feet



Order information

Top size [mm]	Outlet diameter ø [mm]	Foul air trap	Flow rate EN-1253-1 / Direct [l/s]	Material	Item number
------------------	------------------------------	---------------	--	----------	-------------

Standard edge

	200 x 200	75	Without FAT	N/A	1.4301	414704
					1.4404	414804
			With FAT	1.45 / 1.7	1.4301	414705
					1.4404	414805

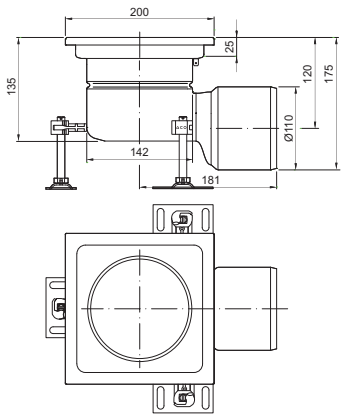
	Top size [mm]	Outlet diameter ø [mm]	Foul air trap	Flow rate EN-1253-1 / Direct [l/s]	Material	Item number	
	200 x 200	110	Without FAT	N/A	1.4301	414706	
					1.4404	414806	
				With FAT	1.45 / 1.7	1.4301	414707
						1.4404	414807

Extended edge

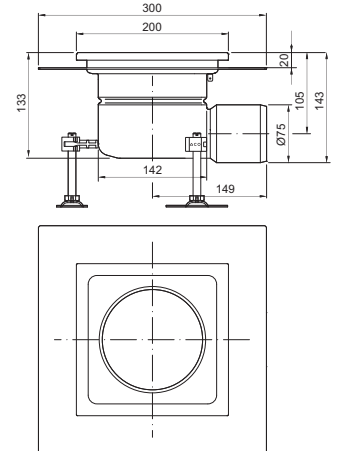
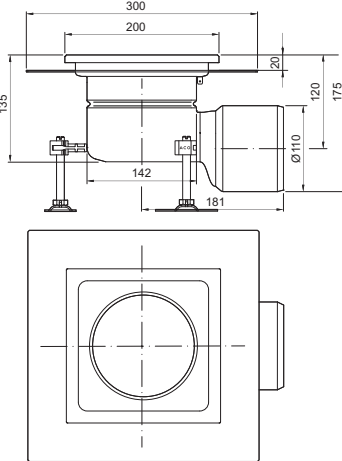
	200 x 200	75	With FAT	1.45 / 1.7	1.4301	414746
					1.4404	414846
	200 x 200	110	With FAT	1.45 / 1.7	1.4301	414747
					1.4404	414847

ACO hygienic gully 142 telescopic, vertical outlet

Product information

Telescopic gully can be combined either with gully tops or with linear drainage channels.

Gullies are equipped with flanges for connection of waterproof membrane.

Telescopic solution enables height and rotational adjustment of connected gully top or channel.

Product benefits

- Hygienic design following EN 1672, EN ISO 14159 and EHEDG document No. 8, 13 and 44
- Fully pickled and passivated
- Fully removable and easily cleanable stainless steel foul air trap (FAT)
- Tested and certified according to EN 1253
- Fire tested and certified solution available for classes EI 90 – EI 180 (EN 13 501-2)
- Suitable for all floor types including vinyl flooring
- Telescopic friction ring included



Order information

	Type of flange	Outlet diameter ø [mm]	Foul air trap	Flow rate EN-1253-1 / Direct [l/s]	Material	Item number	
	Location flange	75	Without FAT	N/A	1.4301	414708	
						1.4404	414808
			With FAT	1,4 - 1,7 / 2,1	1.4301	414709	
					1.4404	414809	

Accessories for ACO hygienic gully 142 → Page 101

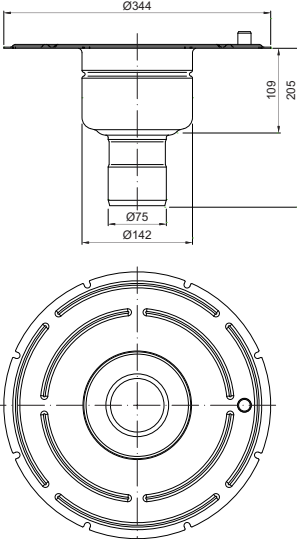
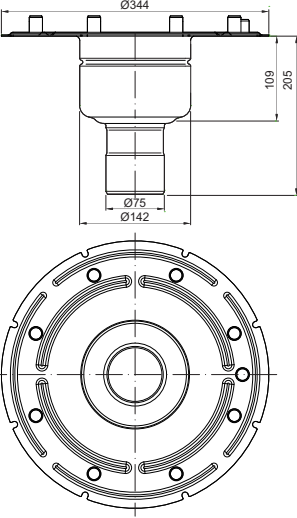
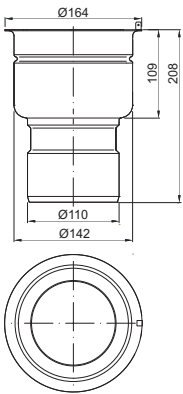
	Type of flange	Outlet diameter ø [mm]	Foul air trap	Flow rate EN-1253-1 / Direct [l/s]	Material	Item number			
	Adhesive bonding flange	75	Without FAT	N/A	1.4301	414710			
					1.4404	414810			
				Mechanical clamping flange	75	Without FAT	N/A	1.4301	414712
								1.4404	414812
						With FAT	1,4 - 1,7 / 2,1	1.4301	414713
								1.4404	414813
	Location flange	110	Without FAT	N/A	1.4301	414714			
					1.4404	414814			
			With FAT	1,6 - 2 / 1,7	1.4301	414715			
					1.4404	414815			

2

ACO hygienic gully 142
telescopic, vertical outlet

2

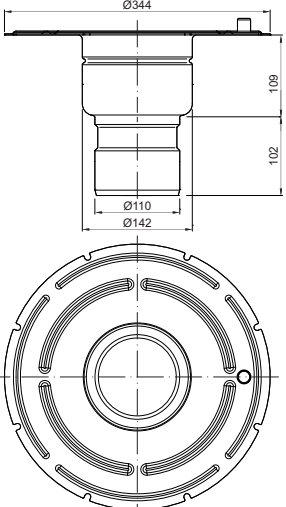
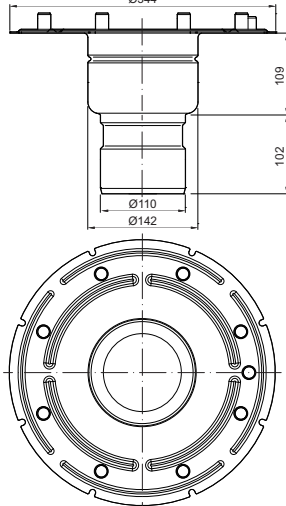
Type of flange	Outlet diameter ø [mm]	Foul air trap	Flow rate EN-1253-1 / Direct [l/s]	Material	Item number
 <p>Adhesive bonding flange</p>	110	Without FAT	N/A	1.4301	414716
		With FAT	1,6 - 2 / 1,7	1.4404	414816
		Without FAT	N/A	1.4301	414717
		With FAT	1,6 - 2 / 1,7	1.4404	414817
 <p>Mechanical clamping flange</p>	110	Without FAT	N/A	1.4301	414718
		With FAT	1,6 - 2 / 1,7	1.4404	414818
		Without FAT	N/A	1.4301	414719
		With FAT	1,6 - 2 / 1,7	1.4404	414819

ACO hygienic gully 142 telescopic, horizontal outlet

Product information

Telescopic gully can be combined either with ACO gully top or ACO channel in most flooring constructions.

Telescopic solution enables height and rotational adjustment of connected gully top or channel.

Gullies are equipped with flanges for connection of waterproof membrane.

Product benefits

- Hygienic design following EN 1672, EN ISO 14159 and EHEDG document No. 8, 13 and 44
- Fully pickled and passivated
- Fully removable and easily cleanable stainless steel foul air trap (FAT)
- Tested and certified according to EN 1253
- Suitable for all floor types including vinyl flooring
- Telescopic friction ring included
- Adjustable EasyFix levelling feet



2

Order information

	Type of flange	Outlet diameter ø [mm]	Foul air trap	Flow rate EN-1253-1 / Direct [l/s]	Material	Item number	
	With location flange	75	Without FAT	N/A	1.4301	414720	
						1.4404	414820
			With FAT	1,4 - 1,7 / 1,7	1.4301	414721	
					1.4404	414821	

ACO hygienic gully 142
telescopic, horizontal outlet

2

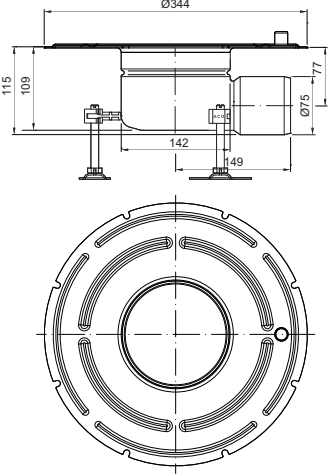
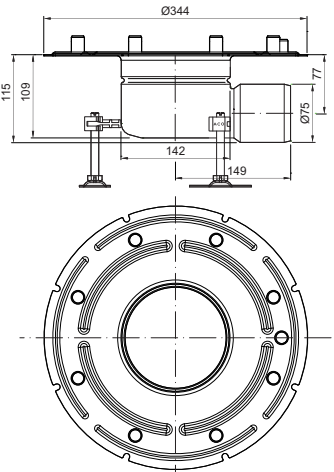
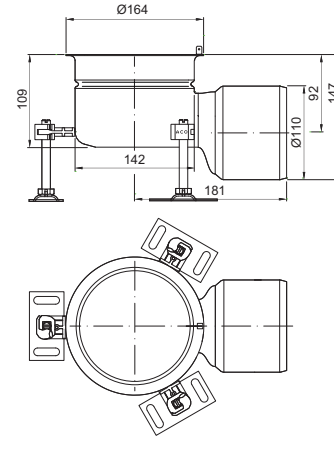
	Type of flange	Outlet diameter ø [mm]	Foul air trap	Flow rate EN-1253-1 / Direct [l/s]	Material	Item number	
	With adhesive bonding flange	75	Without FAT	N/A	1.4301	414722	
						1.4404	414822
			With FAT	1,4 - 1,7 / 1,7	1.4301	414723	
					1.4404	414823	
	With mechanical clamping flange	75	Without FAT	N/A	1.4301	414724	
						1.4404	414824
			With FAT	1,4 - 1,7 / 1,7	1.4301	414725	
					1.4404	414825	
	With location flange	110	Without FAT	N/A	1.4301	414726	
						1.4404	414826
			With FAT	1,4 - 1,7 / 1,7	1.4301	414727	
					1.4404	414827	

Accessories for ACO hygienic gully 142 → Page 101

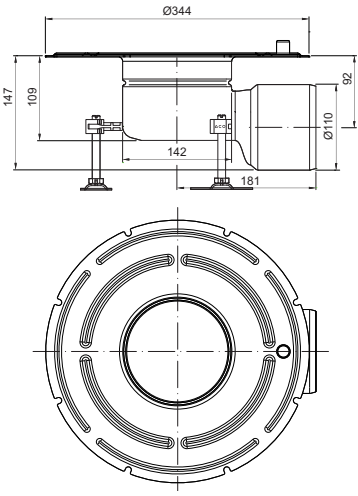
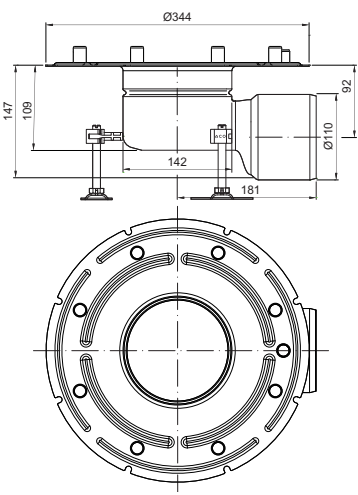
Type of flange	Outlet diameter ø [mm]	Foul air trap	Flow rate EN-1253-1 / Direct [l/s]	Material	Item number
 <p>With adhesive bonding flange</p>	110	Without FAT	N/A	1.4301	414728
		With FAT	1,4 - 1,7 / 1,7	1.4404	414828
		Without FAT	N/A	1.4301	414729
		With FAT	1,4 - 1,7 / 1,7	1.4404	414829
 <p>With mechanical clamping flange</p>	110	Without FAT	N/A	1.4301	414730
		With FAT	1,4 - 1,7 / 1,7	1.4404	414830
		Without FAT	N/A	1.4301	414731
		With FAT	1,4 - 1,7 / 1,7	1.4404	414831

2

ACO hygienic gully 142 gully top, telescopic

Product information

Gully top can be combined with telescopic gully.

Different gully top types are available depending on floor structure.

Product benefits

- Hygienic design following EN 1672, EN ISO 14159 and EHEDG document No. 8, 13 and 44
- Fully pickled and passivated
- Protective cover available. See page 264 for more details
- Tested and certified according to EN 1253
- Wide range of gratings for load class L 15, R 50, M 125 or N 250 (EN 1253) including slip resistant solution
- Adjustable EasyFix levelling feet



2

Order information

	Gully top type	Gully top size [mm]	Material	Item number
	Standard edge	200 x 200	1.4301	414732
			1.4404	414832
	Extended edge	200 x 200	1.4301	414734
			1.4404	414834

Gratings for gully top 200 x 200 mm → Page 82

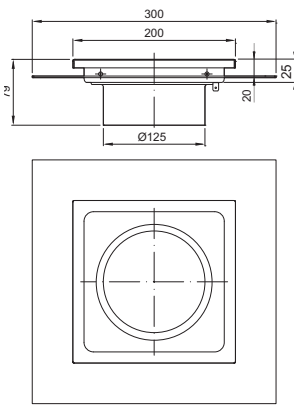
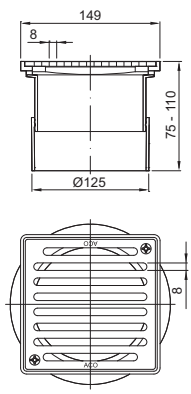
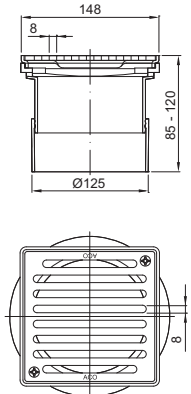
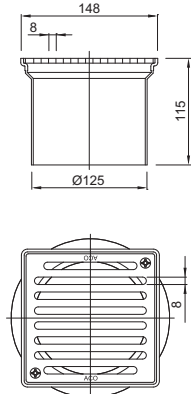
Gully top type	Gully top size [mm]	Material	Item number
	200 x 200	1.4301	414735
	149 x 149	Plastic	414903*
	148 x 148	Plastic	414904*
	148 x 148	1.4301	414905*

* Hygienic design following EN 1672, EN ISO 14159 and EHEDG document No. 8, 13, 44 not applied.

Gratings for gully top 200 x 200 mm → Page 82

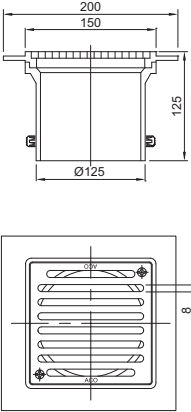
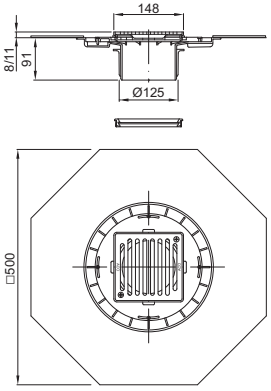
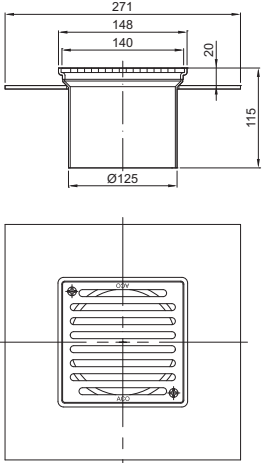
Gully top type	Gully top size [mm]	Material	Item number
	150 x 150	Plastic	414906*
	148 x 148	Plastic	414907*
	148 x 148	1.4301	414909*

* Hygienic design following EN 1672, EN ISO 14159 and EHEDG document No. 8, 13, 44 not applied.

Gratings for gully top 200 x 200 mm → Page 82

ACO hygienic gully 142 raising piece, telescopic

Product information

Raising piece can be used for floor structures where multi waterproofing is needed (heat insulation) or where construction height of the slab needs to be increased.

Product benefits

- Hygienic design following EN 1672, EN ISO 14159 and EHEDG document No. 8, 13 and 44
- Fully pickled and passivated
- Tested and certified according to EN 1253
- Suitable for all floor types including vinyl flooring
- Variety of flanges for membranes
- Telescopic friction ring included



2

	Type of flange	Material	Item number
	Location flange	1.4301	414736
		1.4404	414836
	Adhesive bonding flange	1.4301	414737
		1.4404	414837
	Mechanical clamping flange	1.4301	414738
		1.4404	414838

Accessories for ACO hygienic gully 142 → Page 101

ACO hygienic gully 157 fixed height, vertical outlet

Product information

Fixed height gully can be specified as a point drainage in areas where waterproofing is independent of the gully body.

Those gullies can be combined with different grates depending on requested load class.

Product benefits

- Hygienic design following EN 1672, EN ISO 14159 and EHEDG document No. 8, 13 and 44
- Fully pickled and passivated
- Fully removable and easily cleanable stainless steel foul air trap (FAT)
- Protective cover available. See page 264 for more details
- Tested and certified according to EN 1253
- Fire tested and certified solution available for classes EI 90 – EI 180 (EN 13 501-2)
- Wide range of gratings for load class L 15, R 50, M 125 or N 250 (EN 1253) including slip resistant solution
- Adjustable EasyFix levelling feet



Order information

Top size [mm]	Outlet diameter ø [mm]	Foul air trap	Flow rate EN-1253-1 / Direct [l/s]	Material	Item number
------------------	---------------------------	---------------	--	----------	-------------

Standard edge

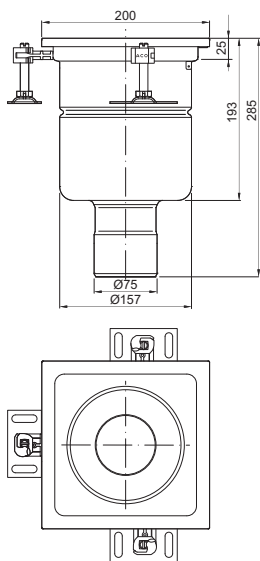

200 x 200	75			1.4301	408000
		Without FAT	N/A		
				1.4404	408100
		With FAT	2.7 / 4	1.4301	408001
				1.4404	408101

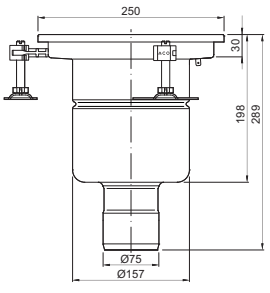
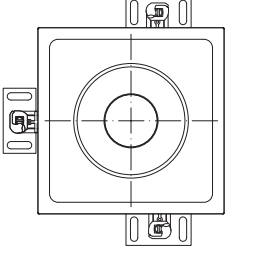
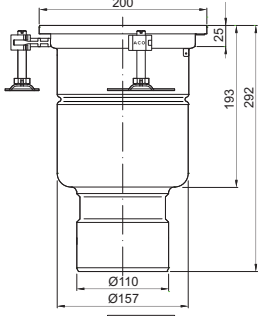
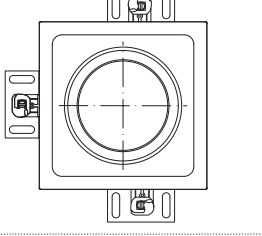
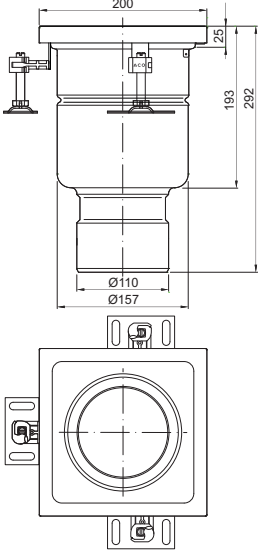
	Top size [mm]	Outlet diameter ø [mm]	Foul air trap	Flow rate EN-1253-1 / Direct [l/s]	Material	Item number
	250 x 250	75	Without FAT	N/A	1.4301	408016
					1.4404	408116
	250 x 250	75	With FAT	2.7 / 4	1.4301	408017
					1.4404	408117
	200 x 200	110	Without FAT	N/A	1.4301	408002
					1.4404	408102
	200 x 200	110	With FAT	3.5 / 4.5	1.4301	408003
					1.4404	408103
	200 x 200 with extended vertical edge and PUR infill	110	With FAT	3.5 / 4.5	1.4301	445556

2

ACO hygienic gully 157
fixed height, vertical outlet

	Top size [mm]	Outlet diameter ø [mm]	Foul air trap	Flow rate EN-1253-1 / Direct [l/s]	Material	Item number
Standard edge						
	250 x 250	110	Without FAT	N/A	1.4301	408018
					1.4404	408118
			With FAT	3.5 / 4.5	1.4301	408019
					1.4404	408119
Extended edge						
	200 x 200	75	With FAT	2.7 / 4	1.4301	408047
					1.4404	408147
	200 x 200	110	With FAT	3.5 / 4.5	1.4301	408099
					1.4404	408199

ACO hygienic gully 157 fixed height, vertical outlet, round top

Product information

Fixed height gully can be specified as a point drainage in areas where waterproofing is independent of the gully body.

Those gullies can be combined with different grates depending on requested load class.

Product benefits

- Hygienic design following EN 1672, EN ISO 14159 and EHEDG document No. 8, 13 and 44
- Fully pickled and passivated
- Fully removable and easily cleanable stainless steel foul air trap (FAT)
- Tested and certified according to EN 1253
- Wide range of gratings including slip resistant solution
- Fire tested and certified solution available for classes EI 90 – EI 180 (EN 13 501-2)
- Adjustable EasyFix levelling feet



2

Order information

	Top size ø [mm]	Outlet diameter ø [mm]	Foul air trap	Flow rate EN-1253-1 / Direct [l/s]	Material	Item number
	230	75	Without FAT	N/A	1.4301	446734
					1.4404	446742
	230	75	With FAT	2.7 / 4	1.4301	446735
					1.4404	446743

ACO hygienic gully 157
fixed height, vertical outlet, round top

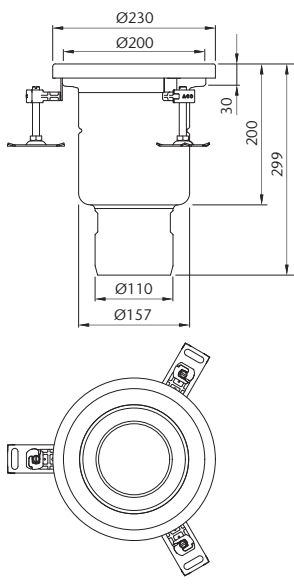
	Top size ø [mm]	Outlet diameter ø [mm]	Foul air trap	Flow rate EN-1253-1 / Direct [l/s]	Material	Item number
	230	110	Without FAT	N/A	1.4301	446736
					1.4404	446744
			With FAT	3.5 / 4.5	1.4301	446737
					1.4404	446745

2

ACO hygienic gully 157 fixed height, horizontal outlet

Product information

Fixed height gully can be specified as a point drainage in areas where waterproofing is independent of the gully body.

Those gullies can be combined with different grates depending on requested load class.

Product benefits

- Hygienic design following EN 1672, EN ISO 14159 and EHEDG document No. 8, 13 and 44
- Fully pickled and passivated
- Fully removable and easily cleanable stainless steel foul air trap (FAT)
- Protective cover available. See page 264 for more details
- Tested and certified according to EN 1253
- Wide range of gratings for load class L 15, R 50, M 125 or N 250 (EN 1253) including slip resistant solution
- Adjustable EasyFix levelling feet



Order information

	Top size [mm]	Outlet diameter ø [mm]	Foul air trap	Flow rate EN-1253-1 / Direct [l/s]	Material	Item number
	200 x 200	75	Without FAT	N/A	1.4301	408008
					1.4404	408108
			With FAT	2,6 / 4,2	1.4301	408009
					1.4404	408109

Standard edge

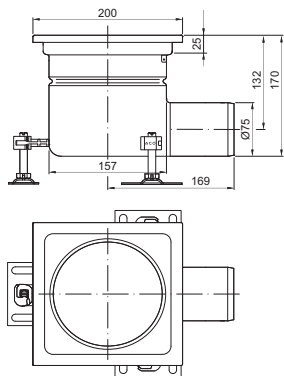

ACO hygienic gully 157
fixed height, horizontal outlet

2

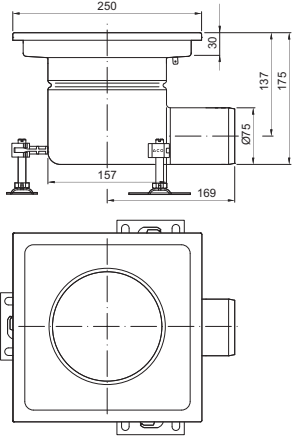
	Top size [mm]	Outlet diameter ø [mm]	Foul air trap	Flow rate EN-1253-1 / Direct [l/s]	Material	Item number
	250 x 250	75	Without FAT	N/A	1.4301	408024
					1.4404	408124
			With FAT	2,6 / 4,2	1.4301	408025
				1.4404	408125	

Standard edge

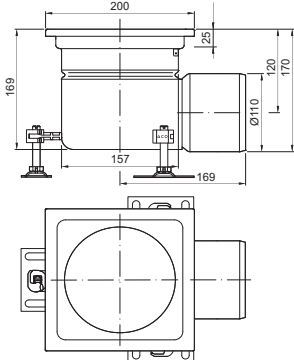
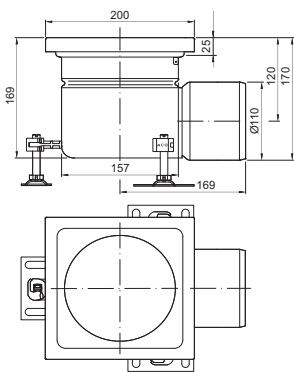
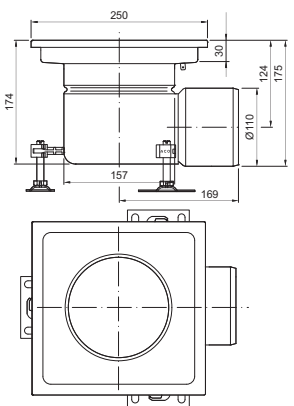
	200 x 200	110	Without FAT	N/A	1.4301	408010
					1.4404	408110
			With FAT	2,8 / 5	1.4301	408011
				1.4404	408111	
	200 x 200 with extended vertical edge and PUR infill	110	With FAT	2,8 / 5	1.4301	445557
					1.4404	408111
	250 x 250	110	Without FAT	N/A	1.4301	408026
					1.4404	408126
			With FAT	2,8 / 5	1.4301	408027
				1.4404	408127	

Gratings for gully top 200 x 200 mm → Page 82
Gratings for gully top 250 x 250 mm → Page 88

Accessories for ACO hygienic gully 157 → Page 102

	Top size [mm]	Outlet diameter ø [mm]	Foul air trap	Flow rate EN-1253-1 / Direct [l/s]	Material	Item number
Extended edge						
	200 x 200	75	With FAT	2,6 / 4,2	1.4301	408014
					1.4404	408114
	200 x 200	110	With FAT	2,8 / 5	1.4301	408015
					1.4404	408115

2

ACO hygienic gully 157 fixed height, horizontal outlet, round top

Product information

Fixed height gully can be specified as a point drainage in areas where waterproofing is independent of the gully body.

Those gullies can be combined with different grates depending on requested load class.

Product benefits

- Hygienic design following EN 1672, EN ISO 14159 and EHEDG document No. 8, 13 and 44
- Fully pickled and passivated
- Fully removable and easily cleanable stainless steel foul air trap (FAT)
- Protective cover available. See page 264 for more details
- Tested and certified according to EN 1253
- Wide range of gratings including slip resistant solution
- Adjustable EasyFix levelling feet



Order information

	Top size ø [mm]	Outlet diameter ø [mm]	Foul air trap	Flow rate EN-1253-1 / Direct [l/s]	Material	Item number
	230	75	Without FAT	N/A	1.4301	446738
					1.4404	446746
	230	75	With FAT	2,6 / 4,2	1.4301	446739
					1.4404	446747

	Top size ø [mm]	Outlet diameter ø [mm]	Foul air trap	Flow rate EN-1253-1 / Direct [l/s]	Material	Item number	
	230	110	Without FAT	N/A	1.4301	446740	
						1.4404	446748
			With FAT	2,8 / 5	1.4301	446741	
					1.4404	446749	

2

ACO hygienic gully 157 telescopic, vertical outlet

Product information

Telescopic gully can be combined either with gully top or ACO channel in most flooring constructions.

Telescopic solution enables height and rotational adjustment of connected gully top or channel.

Gullies are equipped with flanges for connection of waterproof membrane.

Product benefits

- Hygienic design following EN 1672, EN ISO 14159 and EHEDG document No. 8, 13 and 44
- Fully pickled and passivated
- Fully removable and easily cleanable stainless steel foul air trap (FAT)
- Tested and certified according to EN1253
- Fire tested and certified solution available for classes EI90 – EI 180 (EN 13 501-2)
- Suitable for all floor types including vinyl flooring
- Telescopic friction ring included



Order information

	Type of flange	Outlet diameter	Foul air trap	Flow rate		Material	Item number
		ø [mm]		EN-1253-1 / Direct	[l/s]		
	Location flange	75	Without FAT	N/A		1.4301	408048
						1.4404	408148
			With FAT	2,7 - 3,3 / 4		1.4301	408049
						1.4404	408149

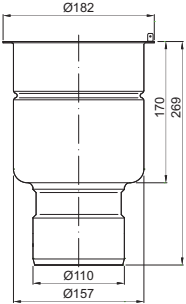
	Type of flange	Outlet diameter ø [mm]	Foul air trap	Flow rate EN-1253-1 / Direct [l/s]	Material	Item number
	Adhesive bonding flange	75	Without FAT	N/A	1.4301	408050
			With FAT	2,7 - 3,3 / 4	1.4301	408051
					1.4404	408150
					1.4404	408151
	Mechanical clamping flange	75	Without FAT	N/A	1.4301	408052
			With FAT	2,7 - 3,3 / 4	1.4301	408053
					1.4404	408152
					1.4404	408153
	Location flange	110	Without FAT	N/A	1.4301	408054
			With FAT	3,5 - 4,4 / 4,5	1.4301	408055
					1.4404	408154
					1.4404	408155

2

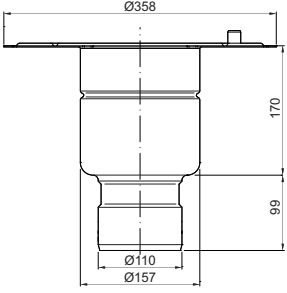
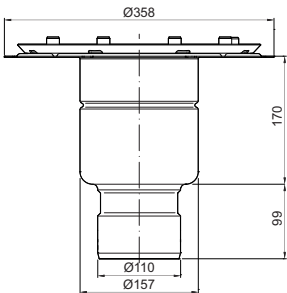
	Type of flange	Outlet diameter ø [mm]	Foul air trap	Flow rate EN-1253-1 / Direct [l/s]	Material	Item number
	Adhesive bonding flange	110	Without FAT	N/A	1.4301	408056
			With FAT	3,5 - 4,4 / 4,5	1.4404	408156
			Without FAT	N/A	1.4301	408057
			With FAT	3,5 - 4,4 / 4,5	1.4404	408157
	Mechanical clamping flange	110	Without FAT	N/A	1.4301	408058
			With FAT	3,5 - 4,4 / 4,5	1.4404	408158
			Without FAT	N/A	1.4301	408059
			With FAT	3,5 - 4,4 / 4,5	1.4404	408159

ACO hygienic gully 157 telescopic, horizontal outlet

Product information

Telescopic gully can be combined either with gully top or ACO channel in most flooring constructions.

Telescopic solution enables height and rotational adjustment of connected gully top or channel.

Gullies are equipped with flanges for connection of waterproof membrane.

Product benefits

- EN ISO 14159 and EHEDG document No. 8, 13 and 44
- Fully pickled and passivated
- Fully removable and easily cleanable stainless steel foul air trap (FAT)
- Tested and certified according to EN 1253
- Suitable for all floor types including vinyl flooring
- Telescopic friction ring included
- Adjustable EasyFix levelling feet



2

Order information

	Type of flange	Outlet diameter ø [mm]	Foul air trap	Flow rate EN-1253-1 / Direct [l/s]	Material	Item number	
	Location flange	75	Without FAT	N/A	1.4301	408072	
						1.4404	408172
			With FAT	2,6 - 3,3 / 4,2	1.4301	408073	
					1.4404	408173	

ACO hygienic gully 157
telescopic, horizontal outlet

2

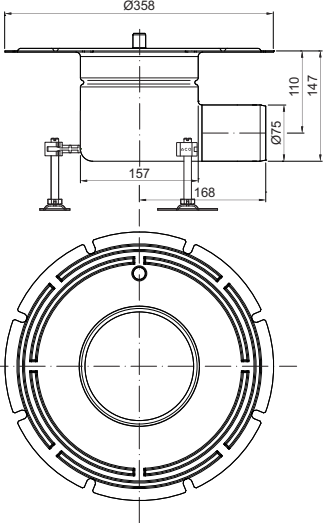
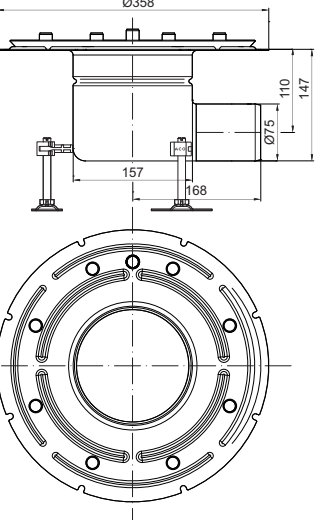
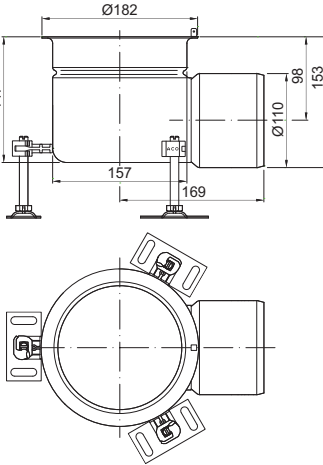
	Type of flange	Outlet diameter ø [mm]	Foul air trap	Flow rate EN-1253-1 / Direct [l/s]	Material	Item number
	Adhesive bonding flange	75	Without FAT	N/A	1.4301	408074
					1.4404	408174
			With FAT	2,6 - 3,3 / 4,2	1.4301	408075
				1.4404	408175	
	Mechanical clamping flange	75	Without FAT	N/A	1.4301	408076
					1.4404	408176
			With FAT	2,8 - 4,4 / 4,5	1.4301	408077
				1.4404	408177	
	Location flange	110	Without FAT	N/A	1.4301	408078
					1.4404	408178
			With FAT	2,8 - 4,4 / 4,5	1.4301	408079
				1.4404	408179	

Accessories for ACO hygienic gully 157 → Page 102

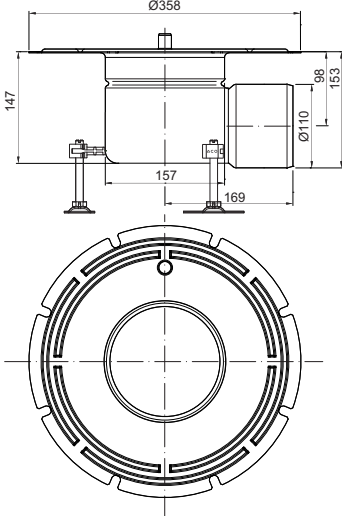
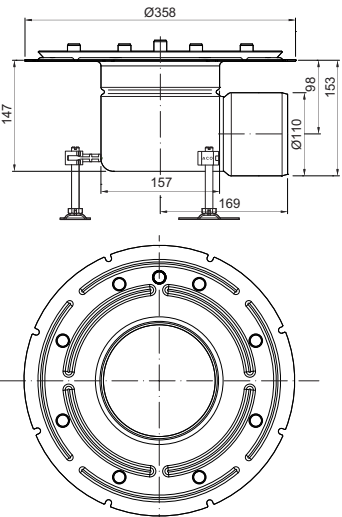
Type of flange	Outlet diameter ø [mm]	Foul air trap	Flow rate EN-1253-1 / Direct [l/s]	Material	Item number
 <p>Adhesive bonding flange</p>	110	Without FAT	N/A	1.4301	408080
		With FAT	2,8 - 4,4 / 4,5	1.4404	408180
		Without FAT	N/A	1.4301	408081
		With FAT	2,8 - 4,4 / 4,5	1.4404	408181
 <p>Mechanical clamping flange</p>	110	Without FAT	N/A	1.4301	408082
		With FAT	2,8 - 4,4 / 4,5	1.4404	408182
		Without FAT	N/A	1.4301	408083
		With FAT	2,8 - 4,4 / 4,5	1.4404	408183

2

ACO hygienic gully 157 gully top, telescopic

Product information

Gully top can be combined with telescopic gully. Different gully

top type is available depending on floor structure.

Product benefits

- Hygienic design following EN 1672, EN ISO 14159 and EHEDG document No. 8, 13 and 44
- Fully pickled and passivated
- Protective cover available. See page 264 for more details
- Tested and certified according to EN 1253
- Wide range of gratings for load class L 15, R 50, M 125 or N 250 (EN 1253) including slip resistant solution
- Adjustable EasyFix levelling feet



2

Order information

	Gully top type	Gully top size [mm]	Material	Item number
	Standard edge	200 x 200	1.4301	408208
			1.4404	408218
	Standard edge	200 x 200 with extended vertical edge	1.4301	446401

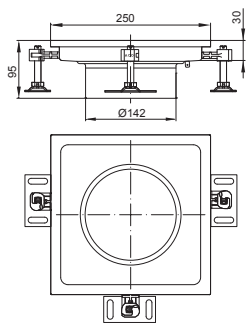
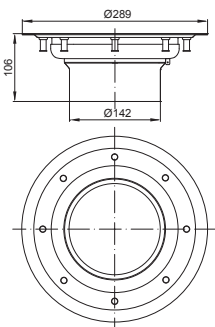
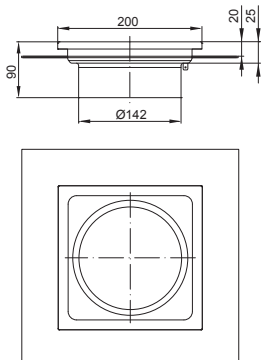
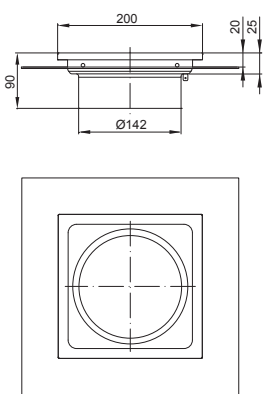
Gully top type	Gully top size [mm]	Material	Item number	
	Standard edge	250 x 250	1.4301	408248
			1.4404	408258
	Vinyl edge	Ø289	1.4301	408240*
			1.4404	408250*
	Extended edge	200 x 200	1.4301	408241
			1.4404	408251
	Extended edge with drainage holes	200 x 200	1.4301	408244
			1.4404	408254

2

* Hygienic design following EN 1672, EN ISO 14159 and EHEDG document No. 8, 13, 44 not applied.

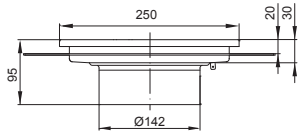
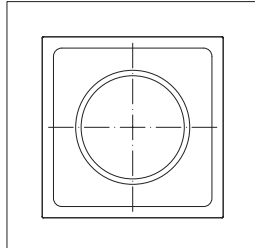
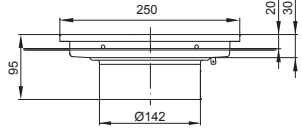
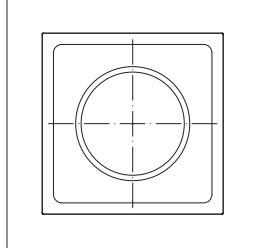
Gully top type	Gully top size [mm]	Material	Item number
		1.4301	408245
Extended edge	250 x 250	1.4404	408255
			
		1.4301	408246
Extended edge with drainage holes	250 x 250	1.4404	408256
			

ACO hygienic gully 157 gully top, telescopic, round top

Product information

Gully top can be combined with telescopic gully. Different gully top type is available depending on floor structure.

Product benefits

- Hygienic design following EN 1672, EN ISO 14159 and EHEDG document No. 8, 13 and 44
- Fully pickled and passivated
- Protective cover available. See page 264 for more details
- Tested and certified according to EN 1253
- Wide range of gratings including slip resistant solution
- Adjustable EasyFix levelling feet



Order information

	Gully top type	Gully top size ø [mm]	Material	Item number
			1.4301	446750
	Standard edge	230		
			1.4404	446751

ACO hygienic gully 157 raising piece, telescopic

Product information

Raising piece can be used for floor structures where multiple water-proofing is needed (heat insulation)

or where construction height of the slab needs to be increased.

Product benefits

- Hygienic design following EN 1672, EN ISO 14159 and EHEDG document No. 8, 13 and 44
- Fully pickled and passivated
- Tested and certified according to EN 1253
- Suitable for all floor types including vinyl flooring
- Variety of flanges for membranes
- Telescopic friction ring included

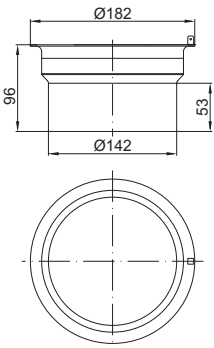
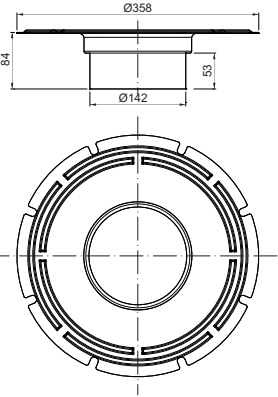

Order information

Type of flange	Material	Item number
	1.4301	408249
Location flange	1.4404	408259
	1.4301	408206
Adhesive bonding flange	1.4404	408216

Type of flange	Material	Item number
	1.4301	408207
	Mechanical clamping flange	1.4404

2

ACO hygienic gully 218 fixed height, vertical outlet - square top

Product information

Fixed height gully can be specified as a point drainage in areas where waterproofing is independent of

the gully body. Those gullies can be combined with different grates depending on requested load class.

Product benefits

- Hygienic design following EN 1672, EN ISO 14159 and EHEDG document No. 8, 13 and 44
- Fully pickled and passivated
- Fully removable and easily cleanable stainless steel foul air trap (FAT)
- Protective cover available. See page 264 for more details
- Tested and certified according to EN 1253
- Fire tested and certified solution available for classes EI 90 – EI 180 (EN 13 501-2)
- Wide range of gratings for load class L 15, R 50, M 125 or N 250 (EN 1253) including slip resistant solution
- Adjustable EasyFix levelling feet



Order information

	Top size	Outlet diameter	Foul air trap	Flow rate EN-1253-1 / Direct	Material	Item number
	[mm]	ø [mm]		[l/s]		
	300 x 300	110	Without FAT	N/A	1.4301	408004
					1.4404	408104
	300 x 300	110	With FAT	4.8 / 5.5	1.4301	408005
					1.4404	408105

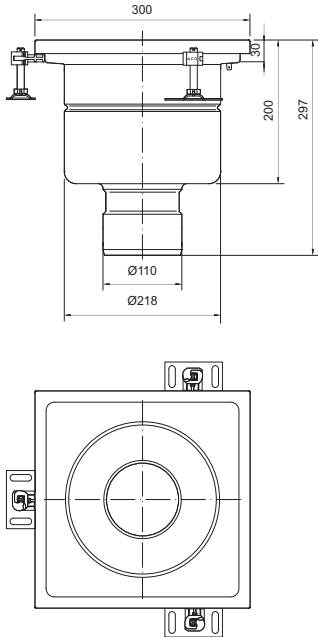
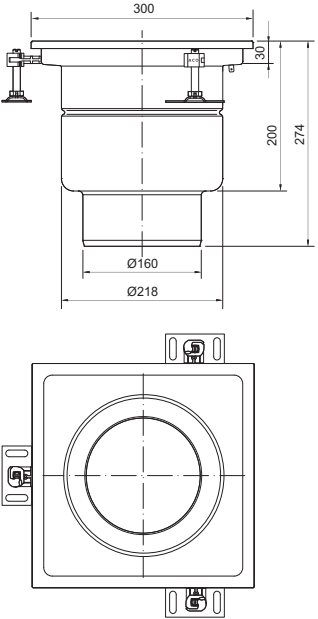
	Top size	Outlet diameter	Foul air trap	Flow rate	Material	Item number	
	[mm]	ø [mm]		EN-1253-1 / Direct [l/s]			
	300 x 300 with extended vertical edge and PUR infill	110	With FAT	4.8 / 5.5	1.4301	445559	
	300 x 300	160	Without FAT	N/A	1.4301	408006	
						1.4404	408106
						1.4301	408007
						1.4404	408107
			With FAT	5.0 / 5.5			

2

ACO hygienic gully 218
fixed height, vertical outlet - square top

2

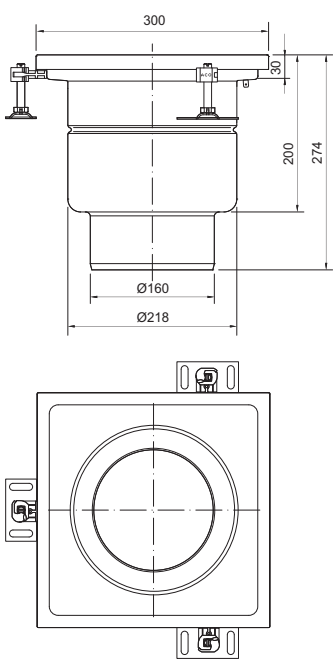
Top size	Outlet diameter	Foul air trap	Flow rate	Material	Item number
[mm]	ø [mm]		EN-1253-1 / Direct [l/s]		
 <p>300 30 200 274 Ø160 Ø218</p> <p>300 x 300 with extended vertical edge and PUR infill</p>	160	With FAT	5.0 / 5.5	1.4301	445560

ACO hygienic gully 218 extended fixed height, vertical outlet

Product information

Fixed height gully can be specified as a point drainage in areas where waterproofing is independent of

the gully body. Those gullies can be combined with different grates depending on requested load class.

Product benefits

- Hygienic design following EN 1672, EN ISO 14159 and EHEDG document No. 8, 13 and 44
- Fully pickled and passivated
- Fully removable and easily cleanable stainless steel foul air trap (FAT)
- Protective cover available. See page 264 for more details
- Tested and certified according to EN 1253
- Fire tested and certified solution available for classes EI 90 – EI 180 (EN 13 501-2)
- Wide range of gratings for load class L 15, R 50, M 125 or N 250 (EN 1253) including slip resistant solution
- Adjustable EasyFix levelling feet



2

Order information

Description	Top size [mm]	Outlet diameter ø [mm]	Foul air trap	Flow rate	Material	Item number
				EN-1253-1 / Direct [l/s]		
Standard edge extended foul air trap	300 x 300	110	Without FAT	N/A	1.4301	446849
					1.4404	446851
			With FAT	6.5 / 9.5	1.4301	446848
					1.4404	446850

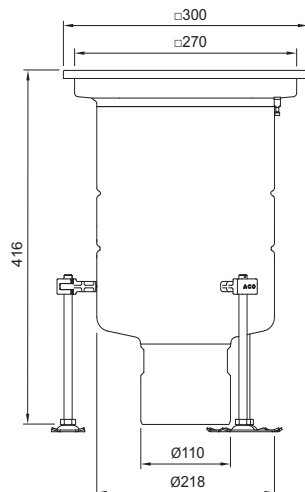

ACO hygienic gully 218
extended fixed height, vertical outlet

2

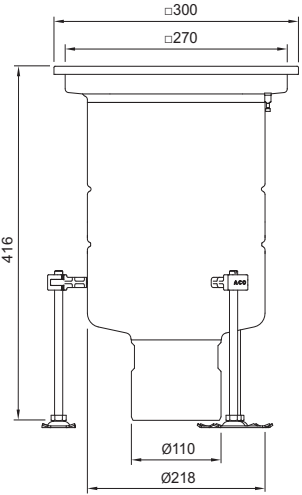
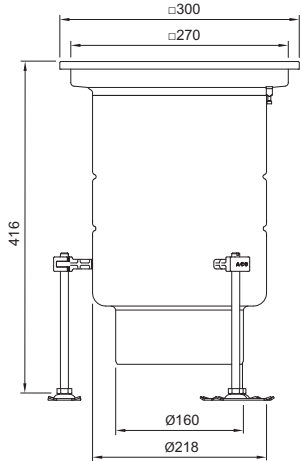
Description	Top size [mm]	Outlet diameter ø [mm]	Foul air trap	Flow rate EN-1253-1 / Direct [l/s]	Material	Item number
 <p>waste filter basket</p>	300 x 300	110	With FAT	6.5 / 4.8	1.4301	446941
					1.4404	446942
 <p>waste filter basket</p>	300 x 300	160	With FAT	6.5 / 4.8	1.4301	446943
					1.4404	446944

ACO hygienic gully 218 fixed height, vertical outlet - round top

Product information

Fixed height gully can be specified as a point drainage in areas where waterproofing is independent of

the gully body. Those gullies can be combined with different grates depending on requested load class.

Product benefits

- Hygienic design following EN 1672, EN ISO 14159 and EHEDG document No. 8, 13 and 44
- Fully pickled and passivated
- Fully removable and easily cleanable stainless steel foul air trap (FAT)
- Protective cover available. See page 264 for more details
- Tested and certified according to EN 1253
- Fire tested and certified solution available for classes EI 90 – EI 180 (EN 13 501-2)
- Wide range of gratings for load class L 15, R 50, M 125 or N 250 (EN 1253) including slip resistant solution
- Adjustable EasyFix levelling feet



2

Order information

	Top diameter	Outlet diameter	Foul air trap	Flow rate EN-1253-1 / Direct	Material	Item number
	[mm]	ø [mm]		[l/s]		
	300	110	Without FAT	N/A	1.4301	446752
					1.4404	446758
			With FAT	4.8 / 5.5	1.4301	446753
					1.4404	446759
	300	160	Without FAT	N/A	1.4301	446754
					1.4404	446760
			With FAT	5.0 / 5.5	1.4301	446755
					1.4404	446761

Standard edge

ACO hygienic gully 218 fixed height, horizontal outlet - square top

Product information

Fixed height gully can be specified as a point drainage in areas where waterproofing is independent of

the gully body. Those gullies can be combined with different grates depending on requested load class.

2

Product benefits

- Hygienic design following EN 1672, EN ISO 14159 and EHEDG document No. 8, 13 and 44
- Fully pickled and passivated
- Fully removable and easily cleanable stainless steel foul air trap (FAT)
- Protective cover available. See page 264 for more details
- Tested and certified according to EN 1253
- Wide range of gratings for load class L 15, R 50, M 125 or N 250 (EN 1253) including slip resistant solution
- Adjustable EasyFix levelling feet



Order information

	Top size [mm]	Outlet diameter ø [mm]	Foul air trap	Flow rate EN-1253-1 / Direct [l/s]	Material	Item number	
	300 x 300	110	Without FAT	N/A	1.4301	408012	
					1.4404	408112	
				With FAT	4,4 / 5	1.4301	408013
						1.4404	408113

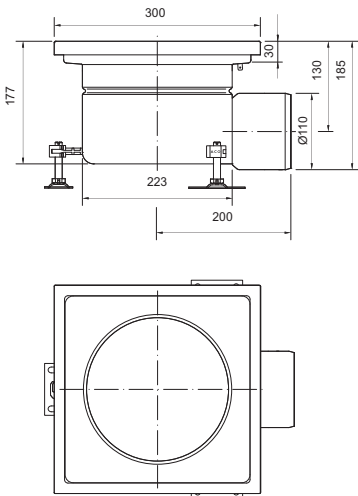
	Top size [mm]	Outlet diameter ø [mm]	Foul air trap	Flow rate EN-1253-1 / Direct [l/s]	Material	Item number
	300	110	With FAT	4,4 / 5	1.4301	445561
	300 x 300 with extended vertical edge and PUR infill					

2

ACO hygienic gully 218 extended fixed height, horizontal outlet

Product information

Fixed height gully can be specified as a point drainage in areas where waterproofing is independent of

the gully body. Those gullies can be combined with different grates depending on requested load class.

2

Product benefits

- Hygienic design following EN 1672, EN ISO 14159 and EHEDG document No. 8, 13 and 44
- Fully pickled and passivated
- Fully removable and easily cleanable stainless steel foul air trap (FAT)
- Protective cover available. See page 264 for more details
- Tested and certified according to EN 1253
- Wide range of gratings for load class L 15, R 50, M 125 or N 250 (EN 1253) including slip resistant solution
- Adjustable EasyFix levelling feet



Order information

Description	Top size [mm]	Outlet diameter ø [mm]	Foul air trap	Flow rate EN-1253-1 / Direct [l/s]	Material	Item number
-------------	------------------	------------------------------	---------------	--	----------	----------------

Standard edge

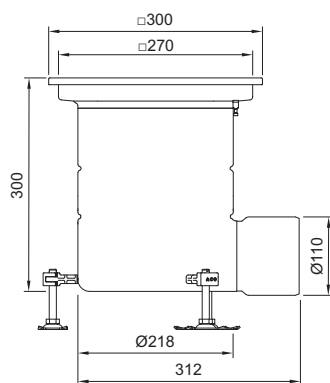

extended
foul air trap

300 x 300

110

Without FAT

N/A

1.4301 447664

1.4404 447666

With FAT

6.5 / 8.8

1.4301 447663

1.4404 447665

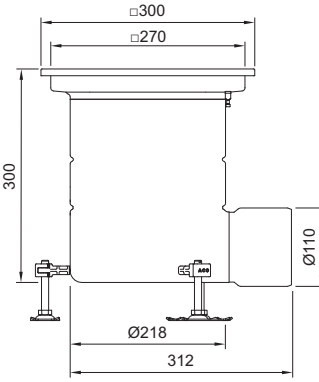
Description	Top size [mm]	Outlet diameter ø [mm]	Foul air trap	Flow rate		Material	Item number
				EN-1253-1 / Direct	[l/s]		
	300 x 300	110	With FAT	6.5 / 8.8	1.4301	446939	
					1.4404	446940	

2

ACO hygienic gully 218 fixed height, horizontal outlet - round top

Product information

Fixed height gully can be specified as a point drainage in areas where waterproofing is independent of

the gully body. Those gullies can be combined with different grates depending on requested load class.

2

Product benefits

- Hygienic design following EN 1672, EN ISO 14159 and EHEDG document No. 8, 13 and 44
- Fully pickled and passivated
- Fully removable and easily cleanable stainless steel foul air trap (FAT)
- Protective cover available. See page 264 for more details
- Tested and certified according to EN 1253
- Wide range of gratings for load class L 15, R 50, M 125 or N 250 (EN 1253) including slip resistant solution
- Adjustable EasyFix levelling feet



Order information

	Top diameter [mm]	Outlet diameter ø [mm]	Foul air trap	Flow rate EN-1253-1 / Direct [l/s]	Material	Item number
	300	110	Without FAT	N/A	1.4301	446756
					1.4404	446762
			With FAT	4.4 / 5	1.4301	446757
					1.4404	446763

ACO hygienic gully 218 telescopic, vertical outlet

Product information

Telescopic gully can be combined either with ACO gully top or ACO channel in most flooring constructions.

Telescopic solution enables height and rotational adjustment of connected gully top or channel.

Gullies are equipped with flanges for connection of waterproof membrane.

Product benefits

- Hygienic design following EN 1672, EN ISO 14159 and EHEDG document No. 8, 13 and 44
- Fully pickled and passivated
- Fully removable and easily cleanable stainless steel foul air trap (FAT)
- Tested and certified according to EN 1253
- Fire tested and certified solution available for classes EI 90 – EI 180 (EN 13 501-2)
- Suitable for all floor types including vinyl flooring
- Telescopic friction ring included



2

Order information

	Type of flange	Outlet diameter ø [mm]	Foul air trap	Flow rate EN-1253-1 / Direct [l/s]	Material	Item number
	Location flange	110	Without FAT	N/A	1.4301	408060
			With FAT	5 - 6,2 / 5,5	1.4404	408160
	Location flange	110	Without FAT	N/A	1.4301	408061
			With FAT	5 - 6,2 / 5,5	1.4404	408161

Accessories for ACO hygienic gully 218 → Page 103

ACO hygienic gully 218
telescopic, vertical outlet

2

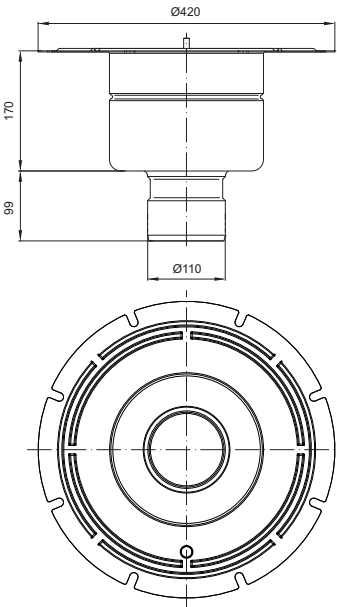
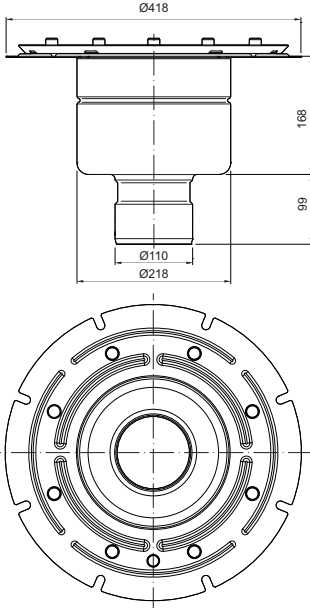
Type of flange	Outlet diameter ø [mm]	Foul air trap	Flow rate EN-1253-1 / Direct [l/s]	Material	Item number
 <p>Adhesive bonding flange</p>	110	Without FAT	N/A	1.4301	408062
		With FAT	5 - 6,2 / 5,5	1.4404	408162
		Without FAT	N/A	1.4301	408063
		With FAT	5 - 6,2 / 5,5	1.4404	408163
 <p>Mechanical clamping flange</p>	110	Without FAT	N/A	1.4301	408064
		With FAT	5 - 6,2 / 5,5	1.4404	408164
		Without FAT	N/A	1.4301	408065
		With FAT	5 - 6,2 / 5,5	1.4404	408165

Accessories for ACO hygienic gully 218 → Page 103

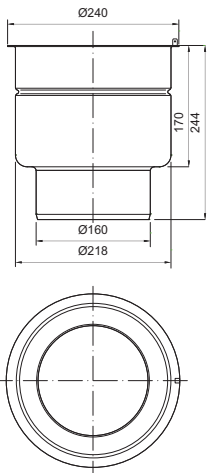
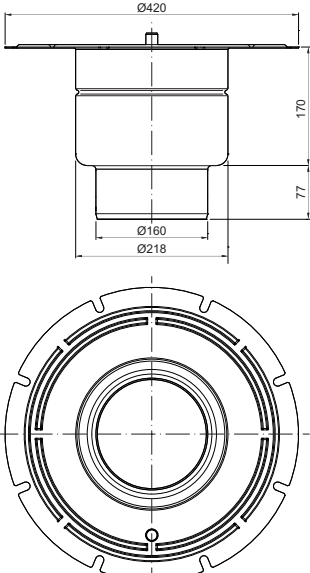
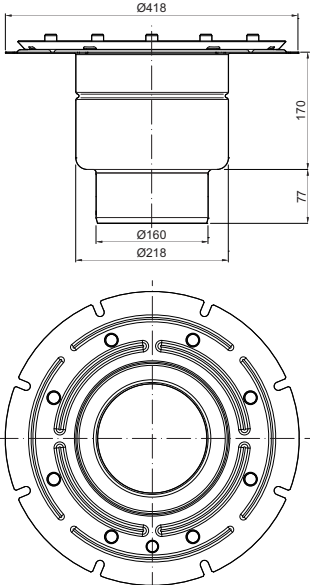
	Type of flange	Outlet diameter ø [mm]	Foul air trap	Flow rate EN-1253-1 / Direct [l/s]	Material	Item number	
	Location flange	160	Without FAT	N/A	1.4301	408066	
					1.4404	408166	
				With FAT	5 - 6,2 / 5,5	1.4301	408067
					1.4404	408167	
		Adhesive bonding flange	160	Without FAT	N/A	1.4301	408068
						1.4404	408168
				With FAT	5 - 6,2 / 5,5	1.4301	408069
					1.4404	408169	
	Mechanical clamping flange	160	Without FAT	N/A	1.4301	408070	
					1.4404	408170	
				With FAT	5 - 6,2 / 5,5	1.4301	408071
					1.4404	408171	

2

ACO hygienic gully 218 telescopic, horizontal outlet

Product information

Telescopic gully can be combined either with gully top or ACO channel in most flooring constructions.

Telescopic solution enables height and rotational adjustment of connected gully top or channel.

Gullies are equipped with flanges for connection of waterproof membrane.

Product benefits

- Hygienic design following EN 1672, EN ISO 14159 and EHEDG document No. 8, 13 and 44
- Fully pickled and passivated
- Fully removable and easily cleanable stainless steel foul air trap (FAT)
- Tested and certified according to EN 1253
- Suitable for all floor types including vinyl flooring
- Telescopic friction ring included
- Adjustable EasyFix levelling feet



Order information

	Type of flange	Outlet diameter ø [mm]	Foul air trap	Flow rate EN-1253-1 / Direct [l/s]	Material	Item number	
	Location flange	110	Without FAT	N/A	1.4301	408084	
					1.4404	408184	
				With FAT	4,4 - 5,4 / 5	1.4301	408085
						1.4404	408185

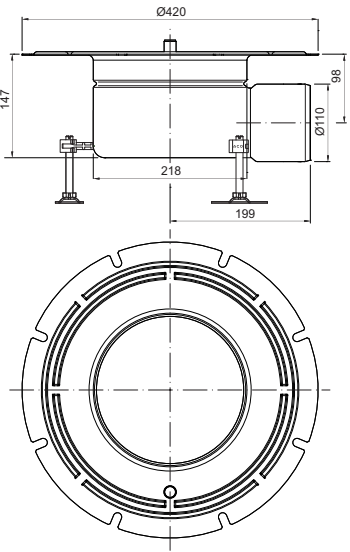
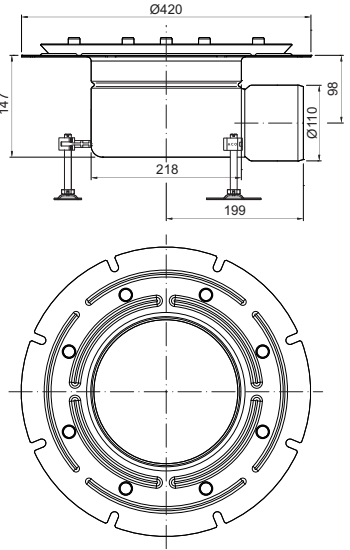
Type of flange	Outlet diameter ø [mm]	Foul air trap	Flow rate EN-1253-1 / Direct [l/s]	Material	Item number	
 <p>Adhesive bonding flange</p>	110	Without FAT	N/A	1.4301	408086	
					1.4404	408186
		With FAT	4,4 - 5,4 / 5	1.4301	408087	
					1.4404	408187
 <p>Mechanical clamping flange</p>	110	Without FAT	N/A	1.4301	408088	
					1.4404	408188
		With FAT	4,4 - 5,4 / 5	1.4301	408089	
					1.4404	408189

2

ACO hygienic gully 218 gully top, telescopic

Product information

Telescopic gully can be combined either with gully top or ACO channel in most flooring constructions.

Telescopic solution enables height and rotational adjustment of connected gully top or channel.

Gullies are equipped with flanges for connection of waterproof membrane.

Product benefits

- Hygienic design following EN 1672, EN ISO 14159 and EHEDG document No. 8, 13 and 44
- Fully pickled and passivated
- Protective cover available. See page 264 for more details
- Tested and certified according to EN 1253
- Wide range of gratings for load class L 15, R 50, M 125 or N 250 (EN 1253) including slip resistant solution
- Adjustable EasyFix levelling feet



2

Order information

	Gully Top type	Gully Top size [mm]	Material	Item number
	Standard edge	300 x 300	1.4301	408228
			1.4404	408238
	Standard edge	300 x 300 with extended vertical edge	1.4301	446402

Gratings for gully top 300 x 300 mm → Page 92

Accessories for ACO hygienic gully 218 → Page 103

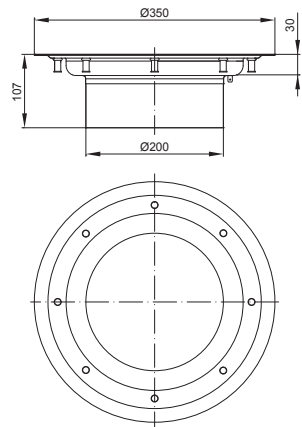
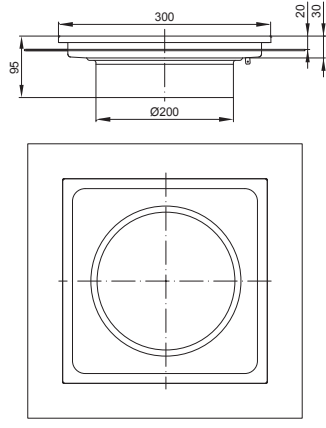
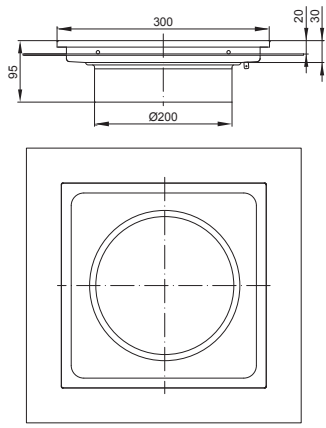
Gully Top type	Gully Top size [mm]	Material	Item number	
	Vinyl edge	Ø350	1.4301	408242*
			1.4404	408252*
	Extended edge	300 x 300	1.4301	408243
			1.4404	408253
	Extended edge with drainage holes	300 x 300	1.4301	408247
			1.4404	408257

* Hygienic design following EN 1672, EN ISO 14159 and EHEDG document No. 8, 13, 44 not applied.



Gratings for gully top 300 x 300 mm → Page 92
Gratings for vinyl top Ø222 mm → Page 100

Accessories for ACO hygienic gully 218 → Page 103

ACO hygienic gully 218 gully top, telescopic, round top

Product information

Gully top can be combined with telescopic gully. Different gully top type is available depending on floor structure.

Product benefits

- Hygienic design following EN 1672, EN ISO 14159 and EHEDG document No. 8, 13 and 44
- Fully pickled and passivated
- Protective cover available. See page 264 for more details
- Tested and certified according to EN 1253
- Wide range of gratings including slip resistant solution
- Adjustable EasyFix levelling feet



2

Order information

	Gully top type	Gully top size ø [mm]	Material	Item number
	Standard edge	300	1.4301	446764
			1.4404	446765

ACO hygienic gully 218 raising piece, telescopic

Product information

Raising piece can be used for floor structures where multiple waterproofing is needed

(heat insulation) or where construction height of the slab needs to be increased.

Product benefits

- Hygienic design following EN 1672, EN ISO 14159 and EHEDG document No. 8, 13 and 44
- Fully pickled and passivated
- Tested and certified according to EN 1253
- Suitable for all floor types including vinyl flooring
- Variety of flanges for membranes
- Telescopic friction ring included



2

	Type of flange	Material	Item number
	Location flange	1.4301	408209
		1.4404	408219
	Adhesive bonding flange	1.4301	408226
		1.4404	408236
	Mechanical clamping flange	1.4301	408227
		1.4404	408237

Accessories for ACO hygienic gully 218 → Page 103

ACO hygienic gully 315

Product information

Fixed height gully can be specified as a point drainage in areas where waterproofing is independent of the gully body.

2 pieces are required for ordering grating for ACO gully high capacity.

Product benefits

- Hygienic design following EN 1672, EN ISO 14159 and EHEDG document No. 8, 13 and 44
- Fully pickled and passivated
- Fully removable and easily cleanable stainless steel foul air trap (FAT)
- Protective cover available. See page 264 for more details



2

	Top size [mm]	Outlet diameter ø [mm]	Foul air trap	Flow rate	Material	Item number
				EN-1253-1 / Direct [l/s]		
	400 x 400	160	Without FAT	N/A	1.4301	446845
					1.4404	446847
			With FAT	9.5 / 20	1.4301	446844
					1.4404	446846

ACO hygienic gully 440

Product information

Fixed height gully can be specified as a point drainage in areas where waterproofing is independent of the gully body.

2 pieces are required for ordering grating for ACO gully high capacity.

Product benefits

- Hygienic design following EN 1672, EN ISO 14159 and EHEDG document No. 8, 13 and 44
- Fully pickled and passivated
- Fully removable and easily cleanable stainless steel foul air trap (FAT)
- Protective cover available. See page 264 for more details



	Top size [mm]	Outlet diameter ø [mm]	Foul air trap	Flow rate EN-1253-1 / Direct [l/s]	Material	Item number
	600 x 600	200	Without FAT	N/A	1.4301	446396
					1.4404	446412
	600 x 600	200	With FAT	12 / 32	1.4301	446397
					1.4404	446413

2

ACO gully EG150 telescopic, vertical outlet

Product information

ACO gully EG150 can be combined with ACO channel with outlet diameter 110 mm.

Foul air trap needs to be ordered separately.

Product benefits

- Stainless steel construction for durability and long life



Order information

	FAT	Material	Item number
	Without FAT	1.4301	405066*
		1.4404	402663*
	Without FAT	1.4301	408805*
		1.4404	405312*

* Hygienic design following EN 1672, EN ISO 14159 and EHEDG document No. 8, 13, 44 not applied.

ACO gully EG150 telescopic, horizontal outlet

Product information

ACO gully EG150 can be combined with ACO channel with outlet diameter 110 mm.

Foul air trap needs to be ordered separately.

Product benefits

- Stainless steel construction for durability and long life



2

Order information

	FAT	Material	Item number
	Without FAT	1.4301	406677*
		1.4404	405311*

* Hygienic design following EN 1672, EN ISO 14159 and EHEDG document No. 8, 13, 44 not applied.

Gratings for gully top 200x200

Product information

Variety of grate types is available depending on application and requested load class.

For applications with high hygienic demands ladder grate or cast grate should be selected.

Product benefits

- Hygienic design following EN 1672, EN ISO 14159 and EHEDG document No. 8, 13 and 44
- Fully pickled and passivated
- Fits to stainless steel gully, fully compliant to EN 1253 and NSF International
- Range of gratings suitable to load class L 15, R 50, M 125 or N 250 (EN 1253)
- Slip resistant solution available

Order information

ACO hygienic frameless ladder grating

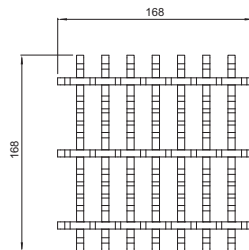

Load class	Slip resistant	Material	Item number
M 125	Yes	1.4301	446264
		1.4404	446265

Note: Surface electropolished

ACO hygienic ladder grating

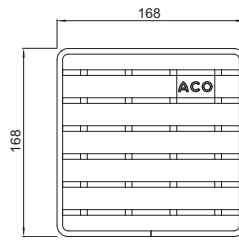

Load class	Slip resistant	Material	Item number
R 50	Yes	1.4301	416912
		1.4404	416913
M 125	Yes	1.4301	408093
		1.4404	408193
N 250	No	1.4301	408043
		1.4404	408143

Note: Surface electropolished

ACO mesh grating

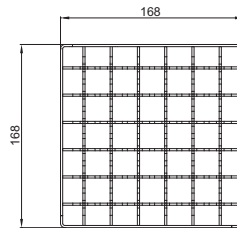
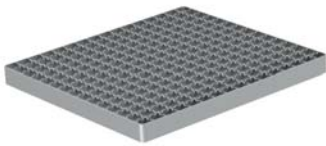

Load class	Slip resistant	Material	Item number
L 15	Yes	1.4301	408090*
		1.4404	408190*
	No	1.4301	408091*
		1.4404	408191*

ACO quadrato grating

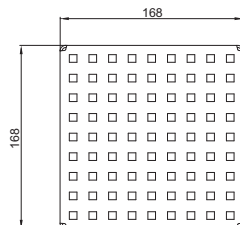

Load class	Slip resistant	Material	Item number
L 15	No	1.4301	408092*
		1.4404	408192*

* Hygienic design following EN 1672, EN ISO 14159 and EHEDG document No. 8, 13, 44 not applied.

ACO heelsafe grating

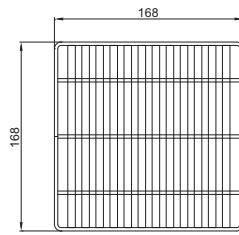

Load class	Slip resistant	Material	Item number
L 15	No	1.4301	408022*
		1.4404	408122*

2

ACO multi-slot 5 grating

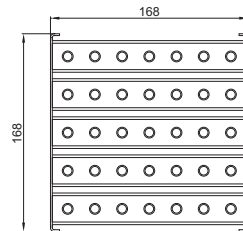

Load class	Slip resistant	Material	Item number
L 15	Yes	1.4301	408094*
		1.4404	408194*

Note: Surface electropolished

ACO hygienic slot cover

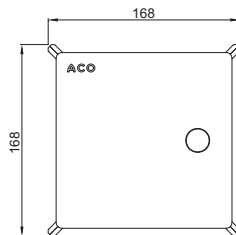
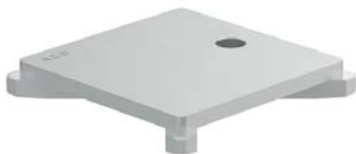

R 50	Yes	1.4301	445780
		1.4404	445781
M 125	Yes	1.4301	445782
		1.4404	445783

Note: Top surface sandblasted

ACO odour proof gully cover

* Hygienic design following EN 1672, EN ISO 14159 and EHEDG document No. 8, 13, 44 not applied.

ACO hygienic gully 142 – fixed height → Page 22, 24
ACO hygienic gully 142 – gully top, telescopic → Page 32

ACO hygienic gully 157 – fixed height → Page 36,, 41
ACO hygienic gully 157 – gully top - telescopic → Page 52
ACO modular slot channel 20 → Page 183

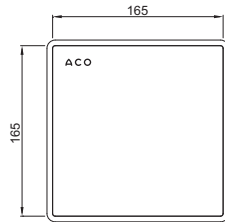

Load class	Slip resistant	Material	Item number
R 50	No	1.4404	445398*
M 125	No	1.4404	445605*

For ACO vacuum handle, please go to page 91

ACO tundish for gully top

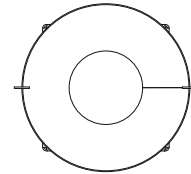
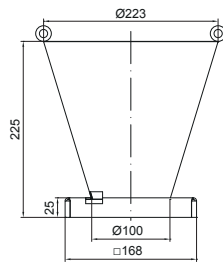

Description	Material	Item number
ACO tundish for gully top 200 x 200	1.4301	415918

* Hygienic design following EN 1672, EN ISO 14159 and EHEDG document No. 8, 13, 44 not applied.

Gratings for gully top \varnothing 230 mm

Product information

Variety of grate types is available depending on application and requested load class.

For applications with high hygienic demands ladder grate or cast grate should be selected.

Product benefits

- Hygienic design following EN 1672, EN ISO 14159 and EHEDG document No. 8, 13 and 44
- Fully pickled and passivated
- Fits to stainless steel gully, fully compliant to EN 1253 and NSF International
- Range of gratings suitable to load class R 50 and M 125 (EN 1253)
- Slip resistant solution available

2

Order information

ACO hygienic frameless ladder grating - round

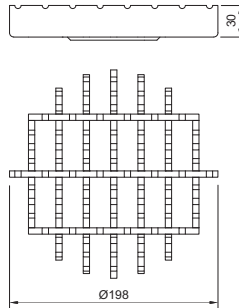

Load class	Slip resistant	Material	Item number
R 50	Yes	1.4301	446780
		1.4404	446781
M 125	Yes	1.4301	446784
		1.4404	446785

Note: Surface electropolished

ACO hygienic ladder grating - round

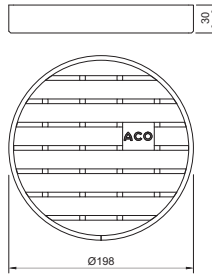

Load class	Slip resistant	Material	Item number
R 50	Yes	1.4301	447761
		1.4404	447762
M 125	Yes	1.4301	446776
		1.4404	446777

Note: Surface electropolished

ACO hygienic slot cover - round

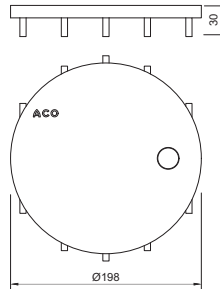

Load class	Slip resistant	Material	Item number
M 125	Yes	1.4301	446788
		1.4404	446789

Note: Top surface sandblasted

ACO perforated grating - round

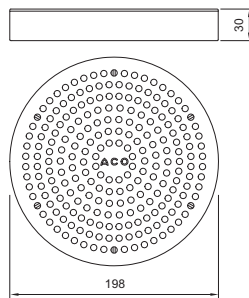
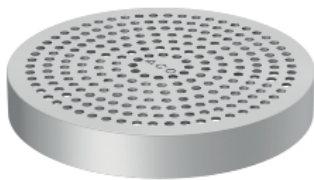

Load class	Slip resistant	Material	Item number
L 15	No	1.4301	447728
		1.4404	447736

Note: Surface electropolished

Gratings for gully top 250x250

Product information

Variety of grate types is available depending on application and requested load class

For applications with high hygienic demands ladder grate or cast grate should be selected.

Product benefits

- Hygienic design following EN 1672, EN ISO 14159 and EHEDG document No. 8, 13 and 44
- Fully pickled and passivated
- Fits to stainless steel gully, fully compliant to EN 1253 and NSF International
- Range of gratings suitable to load class L 15, R 50, M 125 or N 250 (EN 1253)
- Slip resistant solution available

2

Order information

ACO hygienic frameless ladder grating

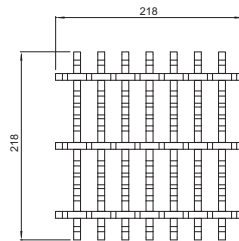

Load class	Slip resistant	Material	Item number
M 125	Yes	1.4301	446268
		1.4404	446269

Note: Surface electropolished

ACO hygienic ladder grating

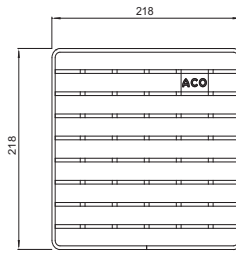

Load class	Slip resistant	Material	Item number
R 50	Yes	1.4301	416914
		1.4404	416915
M 125	Yes	1.4301	408028
		1.4404	408128
N 250	No	1.4301	408044
		1.4404	408144

Note: Surface electropolished

ACO mesh grating

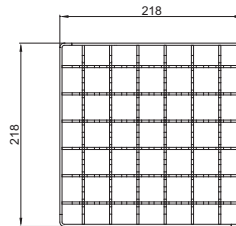
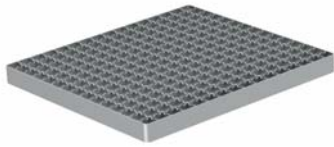

Load class	Slip resistant	Material	Item number
L 15	Yes	1.4301	408095*
		1.4404	408195*
	No	1.4301	408096*
		1.4404	408196*

Note: Surface electropolished

2

ACO quadrato grating

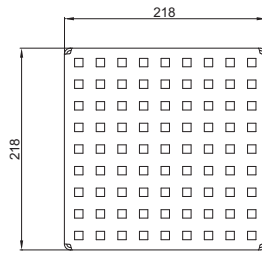

Load class	Slip resistant	Material	Item number
L 15	No	1.4301	408097*
		1.4404	408197*

2

ACO heelsafe grating

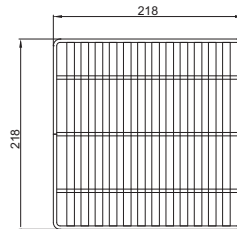

Load class	Slip resistant	Material	Item number
L 15	No	1.4301	408031*
		1.4404	408131*

ACO multi-slot 5 grating

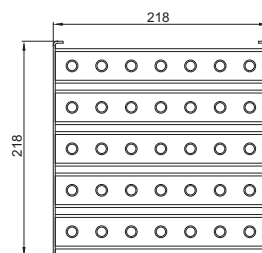

Load class	Slip resistant	Material	Item number
L 15	Yes	1.4301	408033*
		1.4404	408133*

Note: Surface electropolished

* Hygienic design following EN 1672, EN ISO 14159 and EHEDG document No. 8, 13, 44 not applied.

ACO hygienic gully 157 – fixed height → Page 36, 41
ACO hygienic gully 157 – gully top, telescopic → Page 52

ACO hygienic slot cover

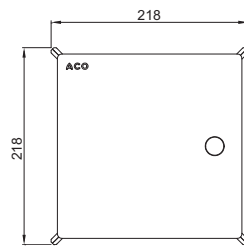

Load class	Slip resistant	Material	Item number
R 50	Yes	1.4301	445784
		1.4404	445785
M 125	Yes	1.4301	445786
		1.4404	445787

Note: Top surface sandblasted

ACO odour proof gully cover

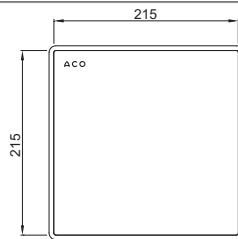

Load class	Slip resistant	Material	Item number
R 50	No	1.4404	445399*
M 125	No	1.4404	445607*

For ACO vacuum handle, please go to page 92

ACO tundish for gully top

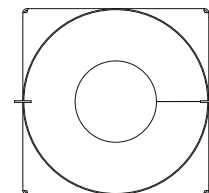
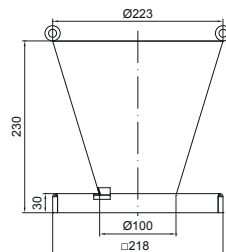

Description	Material	Item number
ACO tundish for gully top 250 x 250	1.4301	413546

* Hygienic design following EN 1672, EN ISO 14159 and EHEDG document No. 8, 13, 44 not applied.

Gratings for gully top 300x300

Product information

Variety of grate types is available depending on application and requested load class.

For applications with high hygienic demands ladder grate or cast grate should be selected.

Product benefits

- Hygienic design following EN 1672, EN ISO 14159 and EHEDG document No. 8, 13 and 44
- Fully pickled and passivated
- Fits to stainless steel gully, fully compliant to EN 1253 and NSF International
- Range of gratings suitable to load class L 15, R 50, M 125 or N 250 (EN 1253)
- Slip resistant solution available

2

ACO hygienic frameless ladder grating

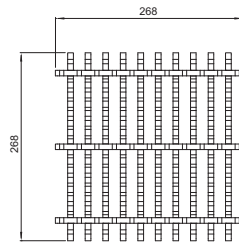

Load class	Slip resistant	Material	Item number
M 125	Yes	1.4301	446272
		1.4404	446273

Note: Surface electropolished

ACO hygienic gully 218 – fixed height → Page 58, 69
ACO hygienic gully 218 – gully top, telescopic → Page 74

ACO hygienic ladder grating

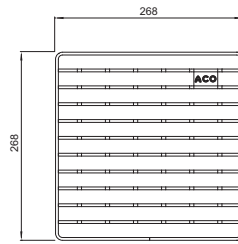

Load class	Slip resistant	Material	Item number
R 50	Yes	1.4301	416916
		1.4404	416917
M 125	Yes	1.4301	408037
		1.4404	408137
N 250	No	1.4301	408045
		1.4404	408145

Note: Surface electropolished

ACO mesh grating

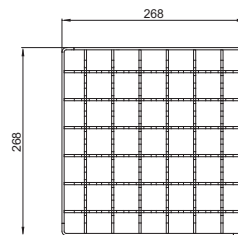
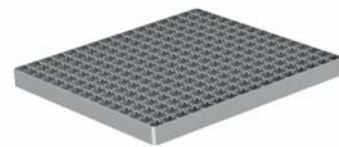

Load class	Slip resistant	Material	Item number
L 15	Yes	1.4301	408034
		1.4404	408134
	No	1.4301	408035*
		1.4404	408135*

Note: Surface electropolished

ACO quadrato grating

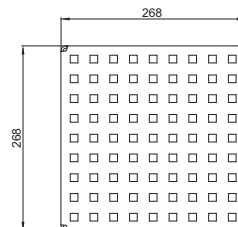
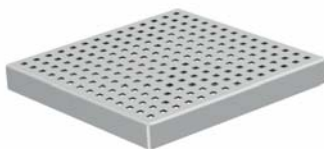

Load class	Slip resistant	Material	Item number
L 15	No	1.4301	408036*
		1.4404	408136*

* Hygienic design following EN 1672, EN ISO 14159 and EHEDG document No. 8, 13, 44 not applied.

ACO heelsafe grating

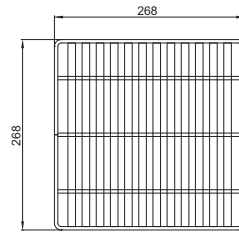
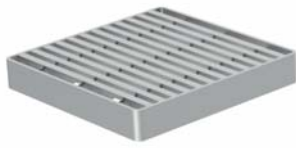

Load class	Slip resistant	Material	Item number
L 15	No	1.4301	408040*
		1.4404	408140*

2

ACO multi-slot 5 grating

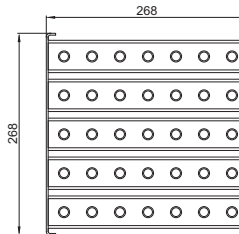

Load class	Slip resistant	Material	Item number
L 15	Yes	1.4301	408042*
		1.4404	408142*

Note: Surface electropolished

ACO hygienic slot cover

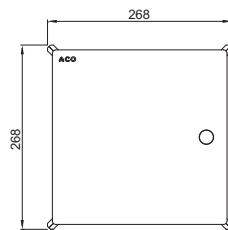

Load class	Slip resistant	Material	Item number
R 50	Yes	1.4301	445788
		1.4404	445789
M 125	Yes	1.4301	445790
		1.4404	445791

Note: Top surface sandblasted

* Hygienic design following EN 1672, EN ISO 14159 and EHEDG document No. 8, 13, 44 not applied.

ACO hygienic gully 218 – fixed height → Page 58, 69
ACO hygienic gully 218 – gully top, telescopic → Page 74

ACO odour proof gully cover

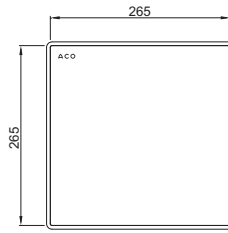
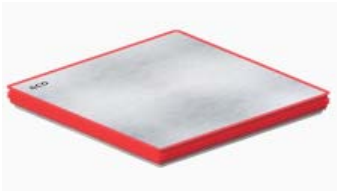

Load class	Slip resistant	Material	Item number
R 50	No	1.4404	445400*
M 125	No	1.4404	445609*

For ACO vacuum handle, please go to page 93

2

ACO tundish for gully top

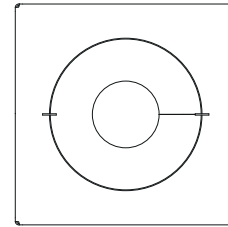
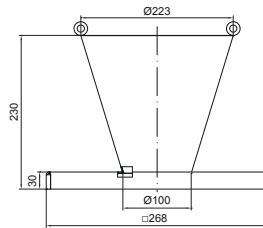

Description	Material	Item number
ACO tundish for gully top 300 x 300	1.4301	413547

* Hygienic design following EN 1672, EN ISO 14159 and EHEDG document No. 8, 13, 44 not applied.

Gratings for gully top ø 300 mm

Product information

Variety of grate types is available depending on application and requested load class.

For applications with high hygienic demands ladder grate or cast grate should be selected.

Product benefits

- Hygienic design following EN 1672, EN ISO 14159 and EHEDG document No. 8, 13 and 44
- Fully pickled and passivated
- Fits to stainless steel gully, fully compliant to EN 1253 and NSF International
- Range of gratings suitable to load class R 50 and M 125 (EN 1253)
- Slip resistant solution available

2

Order information

ACO hygienic frameless ladder grating - round

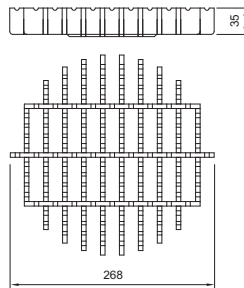

Load class	Slip resistant	Material	Item number
R 50	Yes	1.4301	446782
		1.4404	446783
M 125	Yes	1.4301	446786
		1.4404	446787

Note: Surface electropolished

ACO hygienic ladder grating - round



Load class	Slip resistant	Material	Item number
R 50	Yes	1.4301	447763
		1.4404	447764
M 125	Yes	1.4301	446778
		1.4404	446779

Note: Surface electropolished

ACO hygienic slot cover - round

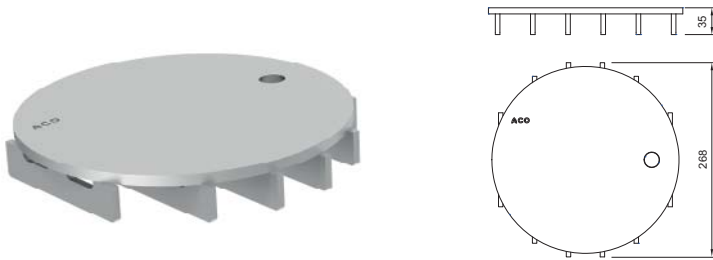

Load class	Slip resistant	Material	Item number
M 125	Yes	1.4301	446790
		1.4404	446791

Note: Top surface sandblasted

ACO perforated grating - round

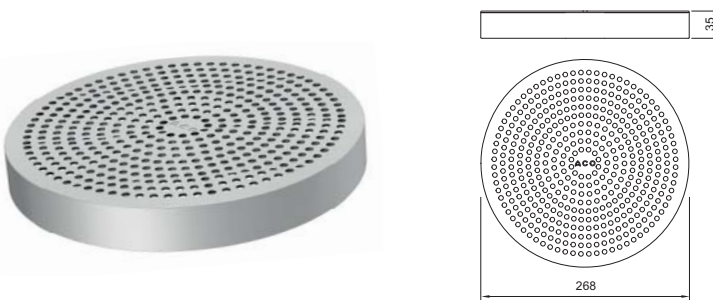

Load class	Slip resistant	Material	Item number
L 15	No	1.4301	447732
		1.4404	447740

Note: Surface electropolished

2

Gratings for vinyl top ø170

Product information

Variety of grate types is available depending on application and requested load class.

For applications with high hygienic demands ladder grate or cast grate should be selected.

Product benefits

- Hygienic design following EN 1672, EN ISO 14159 and EHEDG document No. 8, 13 and 44
- Fully pickled and passivated
- Fits to stainless steel gully, fully compliant to EN 1253
- Stainless steel construction for durability and long life
- Range of gratings suitable to load class L 15 and M 125 (EN 1253)
- Slip resistant solution available

2

ACO ladder grating

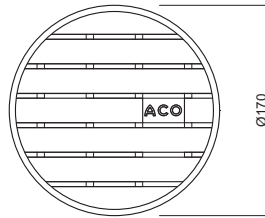

Load class	Slip resistant	Material	Item number
M 125	Yes	1.4301	97146
		1.4404	97367

Note: Surface electropolished

ACO perforated grating

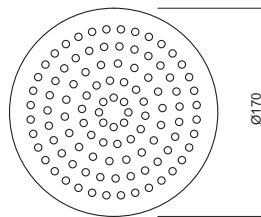

Load class	Slip resistant	Material	Item number
L 15	No	1.4301	97152*
		1.4404	97369*

ACO odour proof gully cover

For ACO odour proof gully cover, please contact our Sales/Technical department.

ACO hygienic gully 157 – gully top, telescopic → Page 52

Gratings for vinyl top ø222

Product information

Variety of grate types is available depending on application and requested load class.

For applications with high hygienic demands ladder grate or cast grate should be selected.

Product benefits

- Hygienic design following EN 1672, EN ISO 14159 and EHEDG document No. 8, 13 and 44
- Fully pickled and passivated
- Fits to stainless steel gully, fully compliant to EN 1253
- Stainless steel construction for durability and long life
- Range of gratings suitable to load class L 15 and M 125 (EN 1253)
- Slip resistant solution available

ACO ladder grating

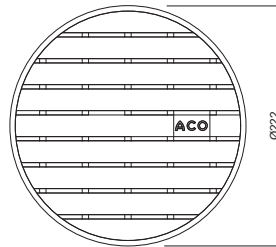

Load class	Slip resistant	Material	Item number
M 125	Yes	1.4301	97148
		1.4404	97388

Note: Surface electropolished

ACO perforated grating

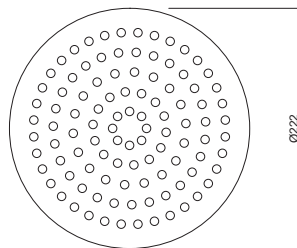

Load class	Slip resistant	Material	Item number
L 15	No	1.4301	97153*
		1.4404	97390*

ACO odour proof gully cover

For ACO odour proof gully cover, please contact our Sales/Technical department.

* Hygienic design following EN 1672, EN ISO 14159 and EHEDG document No. 8, 13, 44 not applied.



ACO hygienic gully 218 – gully top, telescopic → Page 77

Gratings for ACO hygienic gullies 315 and 440

Product information

Variety of grate types is available depending on application and requested load class.

For applications with high hygienic demands ladder grate or cast grate should be selected.

2 pieces are required for ordering grating for ACO hygienic gully high capacity.

Product benefits

- Fully pickled and passivated
- Slip resistant solution available

2

ACO hygienic ladder grating



Designation	Length [mm]	Width [mm]	Height [mm]	Load class	Slip resistant	Material	Item number
ACO gully 315	184	368	30	R 50	Yes	1.4301	447766
						1.4404	447767
ACO gully 440	284	568	30			1.4301	446400
						1.4404	446416

ACO mesh grating

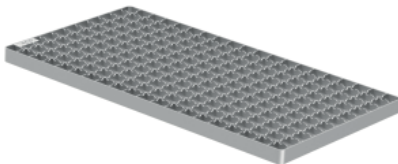







Designation	Length [mm]	Width [mm]	Height [mm]	Load class	Slip resistant	Material	Item number
ACO gully 315	184	368	30	L 15	Yes	1.4301	447825
						1.4404	447822
ACO gully 440	284	568	30			1.4301	447823
						1.4404	447824

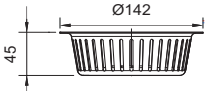
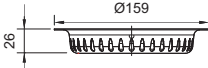
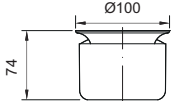

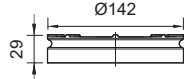
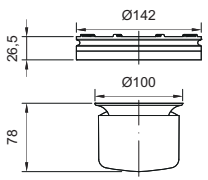

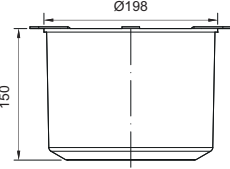

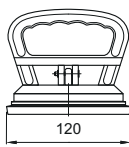
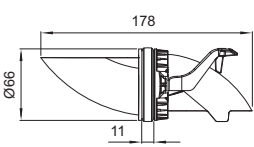
ACO hygienic gully 315 – fixed height → Page 78
ACO hygienic gully 440 – fixed height → Page 79

Accessories

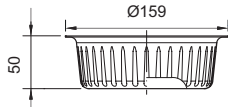
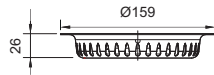
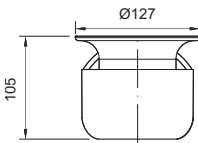

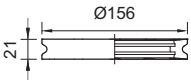
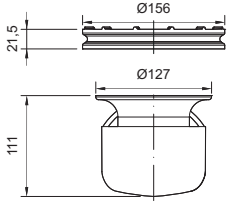
Accessories for ACO hygienic gully 142

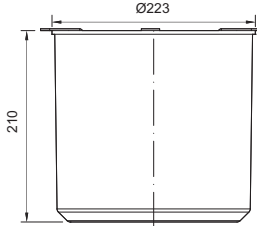
	Description	Used with	Material	Item number
	ACO silt basket ■ Stainless steel ■ 0,4 litre capacity	■ ACO hygienic gully 142, telescopic □ Vertical or horizontal	1.4301	416900
			1.4404	416901
	ACO silt basket ■ Stainless steel ■ 0,3 litre capacity	■ ACO hygienic gully 142, fixed height □ Vertical or horizontal	1.4301	416906
			1.4404	416907
	ACO hygienic foul air trap ■ Stainless steel ■ Water seal 50 mml	■ ACO hygienic gully 142 □ Fixed height □ Telescopic	1.4301	414741
			1.4404	414841
	ACO friction ring ■ SBR (Styrene-butadiene rubber)	■ ACO hygienic gully 142 □ Telescopic	SBR	414742
	ACO standard foul air trap support ■ NBR (Acryl nitrile-butadiene rubber)	■ ACO hygienic gully 142 □ Fixed height □ Telescopic	NBR	414743
	 ACO fire resistant kit for gully 142/DN 70 □ Fixed height, vertical □ Telescopic, vertical	■ ACO hygienic gully 142 □ Fixed height, vertical □ Telescopic, vertical	1.4404 / NBR	416930
				416931
	 ACO fire resistant kit for gully 142/DN 100 □ Fixed height, vertical □ Telescopic, vertical	■ ACO hygienic gully 142 □ Fixed height, vertical □ Telescopic, vertical	1.4404 / NBR	416931
	ACO vacuum handle	■ ACO odour proof gully cover	Aluminium	445622
	ACO foul air trap for horizontal outlet DN70 and DN100 ■ PP (Polypropylene plastic) ■ NBR (Acryl nitrile-butadiene rubber)	■ ACO hygienic gully 142, horizontal □ Fixed height or telescopic	PP / NBR	9575.30.15

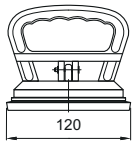
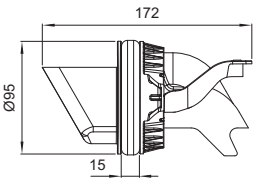
Accessories for ACO hygienic gully 157

	Description	Used with	Material	Item number
	ACO silt basket ■ Stainless steel ■ 0,4 litre capacity	■ ACO hygienic gully 157, vertical <input type="checkbox"/> Fixed height or telescopic	1.4301	416904
			1.4404	416905
	ACO silt basket ■ Stainless steel ■ 0,3 litre capacity	■ ACO hygienic gully 157, horizontal <input type="checkbox"/> Fixed height or telescopic	1.4301	416906
			1.4404	416907
	ACO hygienic foul air trap ■ Stainless steel ■ Water seal 50 mml	■ ACO hygienic gully 157 <input type="checkbox"/> Telescopic	1.4301	408200
			1.4404	408210
	ACO friction ring ■ SBR (Styrene-butadiene rubber)	■ ACO hygienic gully 157 <input type="checkbox"/> Telescopic	SBR	408205
	ACO standard foul air trap support ■ NBR (Acryl nitrile-butadiene rubber)	■ ACO hygienic gully 157 <input type="checkbox"/> Fixed height <input type="checkbox"/> Telescopic	NBR	408201
	 ACO fire resistant kit for gully 157/DN 70 <input type="checkbox"/> Fixed height, vertical <input type="checkbox"/> Telescopic, vertical	■ ACO hygienic gully 157 <input type="checkbox"/> Fixed height, vertical <input type="checkbox"/> Telescopic, vertical	1.4404 / NBR	416932
				416933
	 ACO fire resistant kit for gully 157/DN 100 <input type="checkbox"/> Fixed height, vertical <input type="checkbox"/> Telescopic, vertical	■ ACO hygienic gully 157 <input type="checkbox"/> Fixed height, vertical <input type="checkbox"/> Telescopic, vertical	1.4404 / NBR	416933
	ACO vacuum handle	■ ACO odour proof gully cover	Aluminium	445622
	ACO foul air trap for horizontal outlet DN100 ■ PP (Polypropylene plastic) ■ NBR (Acryl nitrile-butadiene rubber)	■ ACO hygienic gully 157, horizontal <input type="checkbox"/> Fixed height or telescopic	PP / NBR	445845

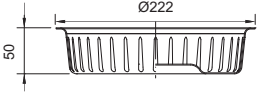
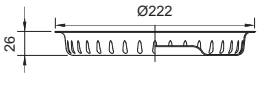
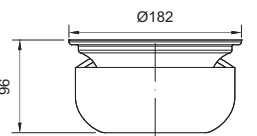
Accessories for ACO hygienic gully 218

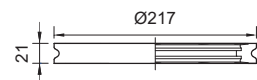
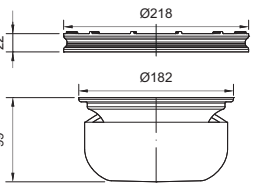
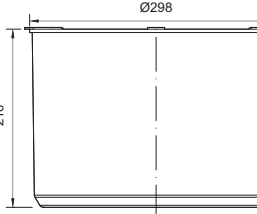
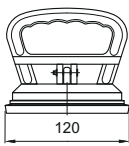
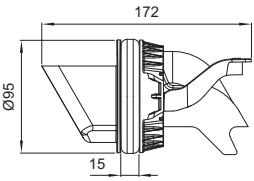
	Description	Used with	Material	Item number
	ACO silt basket ■ Stainless steel ■ 1,4 litre capacity	■ ACO hygienic gully 218, vertical <input type="checkbox"/> Fixed height or telescopic	1.4301	416908
			1.4404	416909
	ACO silt basket ■ Stainless steel ■ 0,7 litre capacity	■ ACO hygienic gully 218, horizontal <input type="checkbox"/> Fixed height or telescopic	1.4301	416910
			1.4404	416911
	ACO hygienic foul air trap ■ Stainless steel ■ Water seal 50 mm	■ ACO hygienic gully 218 <input type="checkbox"/> Fixed height <input type="checkbox"/> Telescopic	1.4301	408220
			1.4404	408230
	ACO friction ring ■ SBR (Styrene-butadiene rubber)	■ ACO hygienic gully 218 <input type="checkbox"/> Telescopic	SBR	408225
	ACO standard foul air trap support ■ NBR (Acryl nitrile-butadiene rubber)	■ ACO hygienic gully 218 <input type="checkbox"/> Fixed height <input type="checkbox"/> Telescopic	NBR	408221
	ACO fire resistant kit for gully 218/DN 110 <input type="checkbox"/> Fixed height, vertical <input type="checkbox"/> Telescopic, vertical	■ ACO hygienic gully 218 <input type="checkbox"/> Fixed height, vertical <input type="checkbox"/> Telescopic, vertical	1.4404 / NBR	416934
	ACO fire resistant kit for gully 218/DN 160 <input type="checkbox"/> Fixed height, vertical <input type="checkbox"/> Telescopic, vertical	■ ACO hygienic gully 218 <input type="checkbox"/> Fixed height, vertical <input type="checkbox"/> Telescopic, vertical	1.4404 / NBR	416935
	ACO vacuum handle	■ ACO odour proof gully cover	Aluminium	445622
	ACO foul air trap for horizontal outlet DN100 <input type="checkbox"/> PP (Polypropylene plastic) <input type="checkbox"/> NBR (Acryl nitrile-butadiene rubber)	■ ACO hygienic gully 218, horizontal <input type="checkbox"/> Fixed height or telescopic	PP / NBR	9515.30.15

Accessories for ACO hygienic gully 218

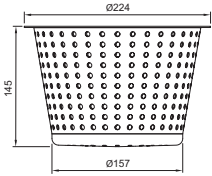
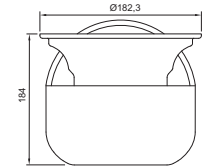
Description	Used with	Material	Item number
	<p>ACO waste filter basket</p> <ul style="list-style-type: none"> ■ Stainless steel 	1.4301	446945
	<p>ACO extended hygienic foul air trap</p> <ul style="list-style-type: none"> ■ Stainless steel 	1.4301	447807
	<ul style="list-style-type: none"> ■ ACO hygienic gully 218 extended fixed height, waste filter basket □ Vertical or horizontal 	1.4404	446946
	<ul style="list-style-type: none"> ■ ACO hygienic gully 218 extended fixed height, extended foul air trap □ Vertical or horizontal 	1.4404	447808

2

Accessories for ACO hygienic gully 315

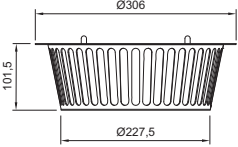
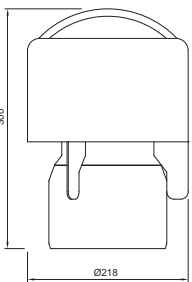
	Description	Used with	Material	Item number
	ACO silt basket ■ Stainless steel	<input checked="" type="checkbox"/> ACO hygienic gully 315 <input type="checkbox"/> Fixed height	1.4301	447681
			1.4404	447682
	ACO hygienic foul air trap ■ Stainless steel	<input checked="" type="checkbox"/> ACO hygienic gully 315 <input type="checkbox"/> Fixed height	1.4301	447673
			1.4404	447674

Accessories for ACO hygienic gully 440

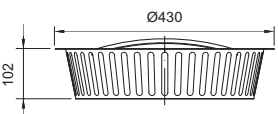
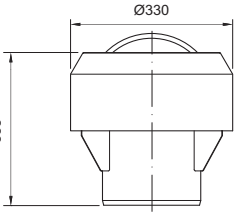
	Description	Used with	Material	Item number
	ACO silt basket ■ Stainless steel	<input checked="" type="checkbox"/> ACO hygienic gully 440 <input type="checkbox"/> Fixed height	1.4301	446399
			1.4404	446415
	ACO hygienic foul air trap ■ Stainless steel	<input checked="" type="checkbox"/> ACO hygienic gully 440 <input type="checkbox"/> Fixed height	1.4301	446398
			1.4404	446414

2

Accessories for ACO gully EG150

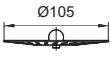
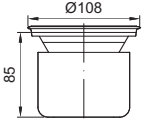
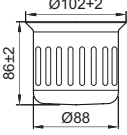
	Description	Used with	Material	Item number
	Sieve (for outlet 110 mm) ■ Stainless steel	<ul style="list-style-type: none"> ■ ACO slot channel 20 ■ ACO modular box channel 125 ■ ACO modular box channel 200 ■ ACO modular slot channel 20 	1.4301	97235
	Foul air trap ■ Stainless steel ■ Water seal 50 mm	<ul style="list-style-type: none"> ■ ACO slot channel 20 ■ ACO modular box channel 125 ■ ACO modular box channel 200 ■ ACO modular slot channel 20 	1.4301	97217
	Silt basket ■ Stainless steel	<ul style="list-style-type: none"> ■ ACO slot channel 20 ■ ACO modular box channel 125 ■ ACO modular box channel 200 ■ ACO modular slot channel 20 ■ Don't combine with FAT ■ Suitable with P-Trap (ACO pipe chapter) 	1.4301	409190
			1.4404	409189

2

ACO tundish portable

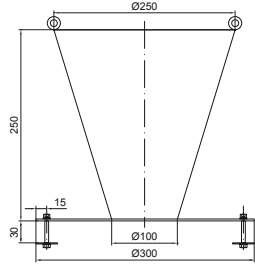
	Description	Material	Item number
 	ACO tundish portable ■ Stainless steel	1.4301	415821

Flow rates and construction heights

ACO hygienic gully 142 – fixed height



Outlet diameter	Outlet position	Flow rate [l/s]	Outlet diameter	Outlet position	Flow rate [l/s]
øD		A = 135 [mm]	øD		A = 135 [mm]
75	Vertical	1.4	75	Horizontal	1.4
110	Vertical	1.6	110	Horizontal	1.6

ACO hygienic gully 142 – telescopic, vertical

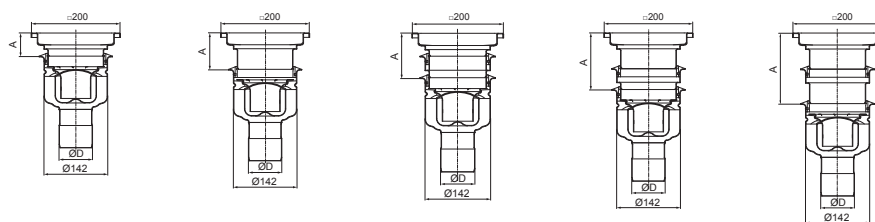

Outlet diameter	Outlet position	Flow rate [l/s]				
		A = 52 [mm]	A = 82 [mm]	A = 97 [mm]	A = 127 [mm]	A = 157 [mm]
75	Vertical	1.4	1.6	1.6	1.7	1.8
110	Vertical	1.6	1.8	1.8	1.9	2.0

ACO hygienic gully 142 – telescopic, horizontal

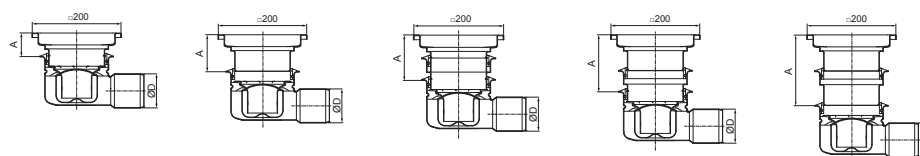

Outlet diameter	Outlet position	Flow rate [l/s]				
		A = 52 [mm]	A = 82 [mm]	A = 97 [mm]	A = 127 [mm]	A = 157 [mm]
75	Horizontal	1.4	1.6	1.6	1.7	1.8
110	Horizontal	1.6	1.8	1.8	1.9	2.0

ACO hygienic gully 157 – fixed height

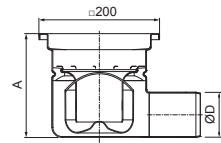
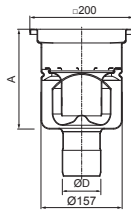

Outlet diameter	Outlet position	Flow rate [l/s]	Outlet diameter	Outlet position	Flow rate [l/s]
øD		A = 193 [mm]	øD		A = 170 [mm]
75	Vertical	2.7	75	Horizontal	2.6
110	Vertical	3.5	110	Horizontal	2.8

2

ACO hygienic gully 157 – telescopic, vertical

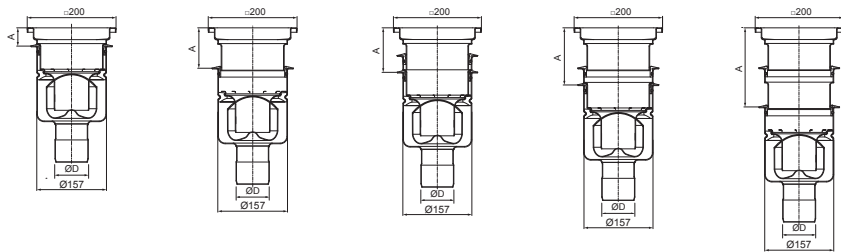

Outlet diameter	Outlet position	Flow rate [l/s]				
		A = 65 [mm]	A = 91 [mm]	A = 125 [mm]	A = 153 [mm]	A = 180 [mm]
75	Vertical	2.7	3.0	3.0	3.1	3.3
110	Vertical	3.5	4.0	4.1	4.2	4.4

ACO hygienic gully 157 – telescopic, horizontal

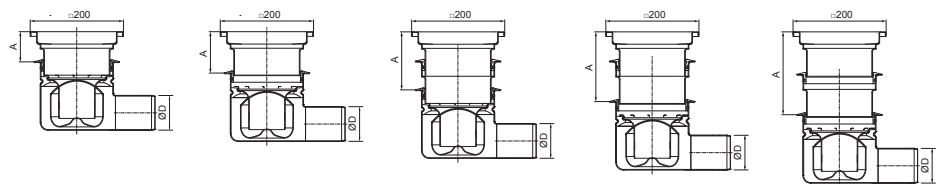

Outlet diameter	Outlet position	Flow rate [l/s]				
		A = 52 [mm]	A = 82 [mm]	A = 97 [mm]	A = 127 [mm]	A = 157 [mm]
75	Horizontal	2.6	2.9	3.0	3.1	3.3
110	Horizontal	2.8	3.3	3.6	4.0	4.4

ACO hygienic gully 218 – fixed height



Outlet diameter	Outlet position	Flow rate [l/s]	Outlet diameter	Outlet position	Flow rate [l/s]
ØD		A = 200 [mm]	ØD		A = 177 [mm]
110	Vertical	5.0	110	Horizontal	4.4
160	Vertical	5.0	-	-	-

2

ACO hygienic gully 218– telescopic, vertical

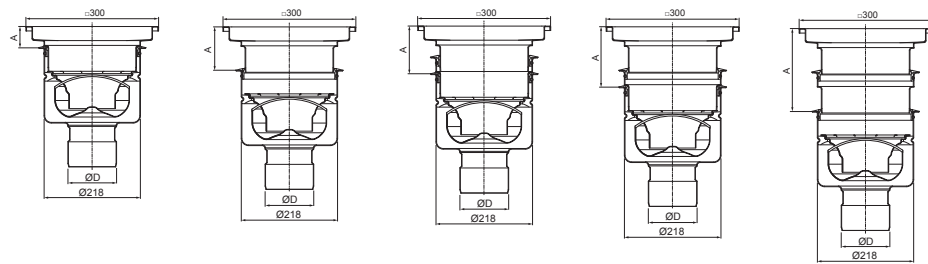

Outlet diameter	Outlet position	Flow rate [l/s]				
ØD		A = 65 [mm]	A = 91 [mm]	A = 125 [mm]	A = 153 [mm]	A = 180 [mm]
110	Vertical	5.0	5.5	5.6	5.8	6.2
160	Vertical	5.0	5.5	5.6	5.8	6.2

ACO hygienic gully 218 – telescopic, horizontal

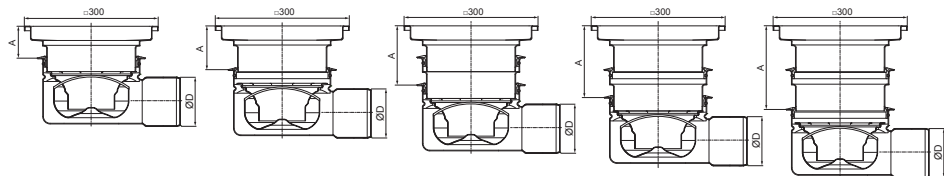

Outlet diameter	Outlet position	Flow rate [l/s]				
ØD		A = 72 [mm]	A = 98 [mm]	A = 132 [mm]	A = 156 [mm]	A = 187 [mm]
110	Horizontal	4.4	4.6	4.8	4.9	5.4



3 ACO Channel

COLLECT:
Collect and remove



ACO Channel

Introduction	Hygienic design	112
	System overview	113
ACO box channel	Introduction to ACO box channel	114
	ACO hygienic box channel, standard articles	116
	ACO hygienic box channel, semi-standard	120
	ACO vinyl box channel, standard articles	122
	ACO vinyl box channel, semi-standard	125
	ACO frameless ladder grating	126
	ACO hygienic ladder grating	128
	ACO mesh grating	134
	ACO hygienic slot cover	136
	Accessories for ACO hygienic box channel	139
	ACO customized box channel	140
ACO slot channel	Introduction to ACO slot channel	146
	ACO slot channel, semi-standard	148
	ACO customized slot channel	149
ACO modular channel	Introduction to ACO modular channel	154
	ACO modular box channel 125, standard articles	158
	Gratings for ACO modular box channel 125	164
	Accessories for ACO modular box channel 125	169
	ACO modular box channel 200, standard articles	170
	Gratings for ACO modular box channel 200	178
	Accessories for ACO modular box channel 200	182
	ACO modular slot channel 20, standard articles	183
	Accessories for ACO modular slot channel 20	189
ACO modular channel, semi-standard	190	
ACO design channel	ACO design channel	191
	ACO channel, ACO hygienic gully 142	192
Flow rates and Construction heights	ACO channel, ACO hygienic gully 157	193
	ACO channel, ACO hygienic gully 218	194
	ACO channel, ACO gully EG150	195



Discover more in a 3D environment:
buildingdrainage.aco/products

ACO channel
online information



Introduction

Hygienic design

ACO offers sustainable, integrated drainage systems which are designed to protect your business, the environment and ultimately public health.

Our aim is to constantly improve every aspect of safety, hygiene and functional performance. We believe that our systems and services are truly unique, delivering unparalleled benefits to everyone involved in

project delivery or subsequent operation.

ACO hygienic drainage fulfils stringent hygienic requirements to prevent harmful bacterial contamination. We apply the relevant hygienic design principles reserved for food contact surfaces EN 1672, EN ISO 14159, EHEDG document to the channel design.

ACO channel hygienic features:

- Fully drainable
- Internal radii equal or larger than 3 mm
- Hygienic joints
- Edge in-fill
- Stainless steel grade min. AISI 304
- Fully pickled and passivated

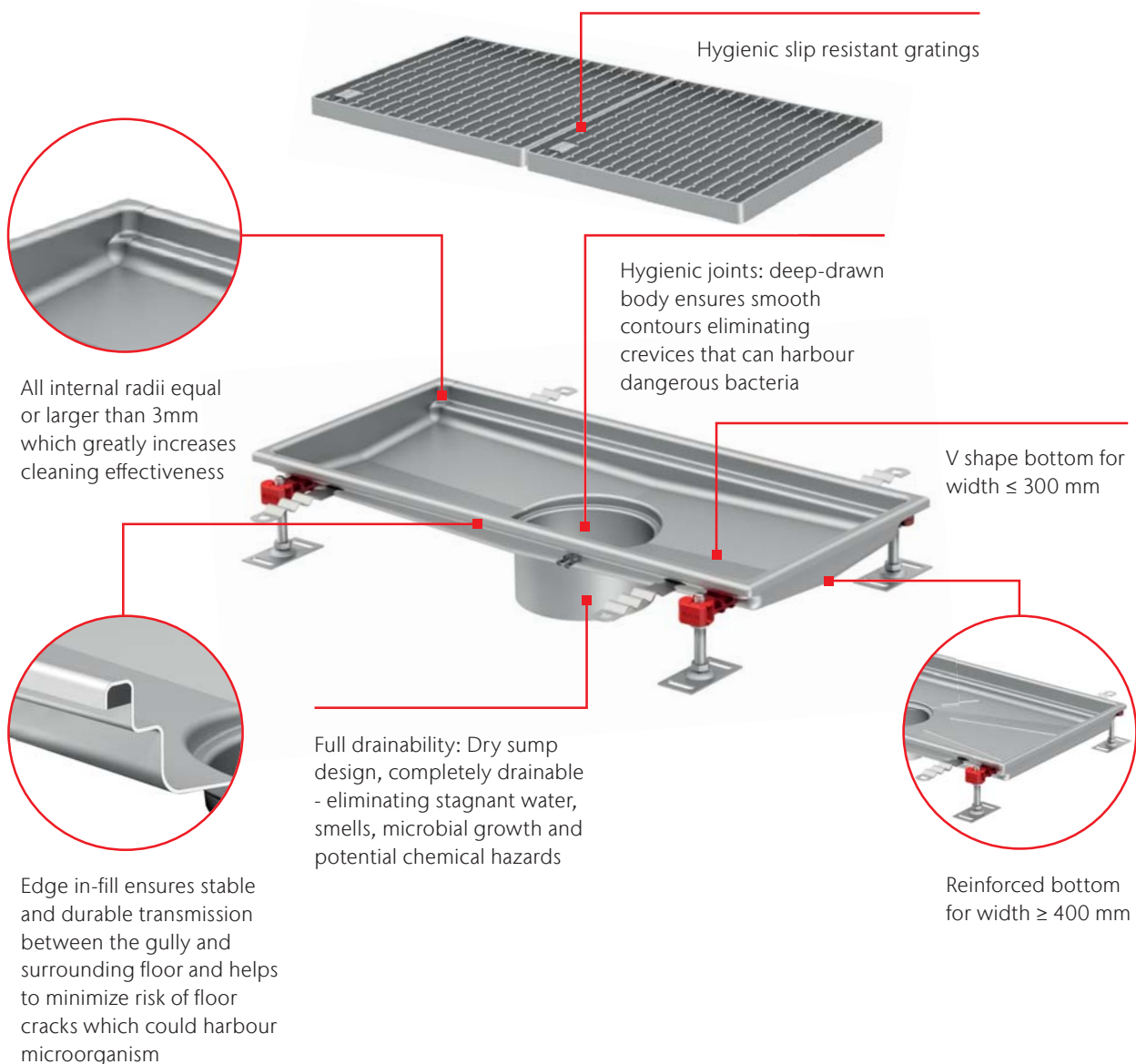

System overview

ACO channel



ACO box channel



ACO slot channel



ACO modular box channel

- 1** Gratings
- 2** Silt basket
- 3** Friction ring
- 4** Foul air trap
- 5** Foul air trap support
- 6** ACO gully



**ACO gully
with accessories**

3

Introduction to ACO box channel

ACO box channel portfolio

The ACO box channel range includes channels for all common applications and all common floor types (concrete, tiles, resin or vinyl).

The ACO box channel portfolio is designed with respect to hygienic design requirements. Selecting a channel from the range is easy. The unique variability of the whole portfolio makes it easy to choose a channel

that suits a customer's specific needs. Channel length, depth and outlet position are just a few of the parameters which can be varied and, regardless of the variations specified, there is no impact on delivery lead times.

ACO box channel ordering

The dimensions of the ACO box channel can be easily specified in respect of project requirements.

To specify the channel please use the Customization template (see page 140) which will help you to identify the information you need, or contact our Sales/Technical department.

ACO box channels with fixed dimensions are also available. These dimensions are a selection of most frequently sold ACO box channels. Please see page 115 where you can find the overview.

ACO box channel customization

3

In addition all ACO box channels can be designed with:

- Special outlet position
- Special depth
- Special slope
- Special channel width
- L-shape and T-shape lay out
- Special side inlets

To ask for customised ACO box channel, please contact our Sales/technical department. Please take into consideration that ACO channel customization could decrease the number of hygienic design features.

ACO box channel system overview

ACO box channel, fixed height solution



**ACO hygienic box channel
Standard edge**

**ACO hygienic box channel
Extended edge**

ACO vinyl box channel

ACO box channel, telescopic solution



**ACO hygienic box channel
Standard edge**

**ACO hygienic box channel
Extended edge**

ACO vinyl box channel



**ACO hygienic gully
with accessories**

ACO hygienic box channel standard articles

Product information

The dimensions of the ACO hygienic box channel for concrete, tiles and resin floor can be easily specified in

respect of project requirements or easily chosen from predefined fixed dimensions.

Product benefits

- Hygienic design following EN 1672, EN ISO 14159 and EHEDG document No. 8, 13 and 44
- Material thickness 1.5 mm
- Fully removable and easily cleanable stainless steel foul air trap (FAT)
- Rubber edge infill
- Fully pickled and passivated
- Minimal longitudinal slope 1%
- Min. sectional slope 5°
- Material thickness 1.5 mm
- Hygienic gratings with slip resistance available
- Protective cover available. See page 264 for more details
- Tested and certified according to EN 1253
- V-shape bottom for width < 300 mm
- Reinforced bottom for width > 400 mm
- Outlet without deformation
- Easy and secure telescopic connection with gully
- Adjustable EasyFix levelling feet 60-110 mm
- Anchors for fixing in concrete

Order information

3

Standard edge

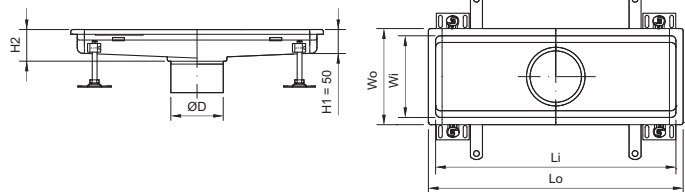

Extended edge

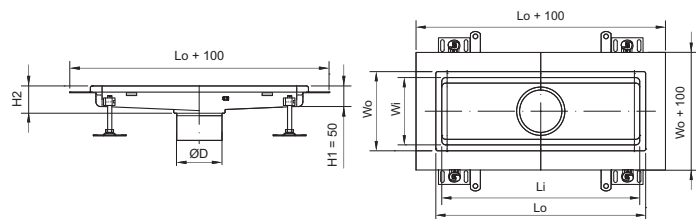

Channel dimensions						Gully	Material	Standard edge	Extended edge					
Wo [mm]	Wi [mm]	Lo [mm]	Li [mm]	H2 [mm]	øD [mm]			Item number	Item number					
200	170	530	500	60	125	ACO hygienic gully 142	1.4301	416584	416680					
		530	500				1.4404	416602	416698					
		830	800				1.4301	416585	416681					
		830	800				1.4404	416603	416699					
		1030	1000				1.4301	416586	416682					
		1030	1000				1.4404	416604	416700					
		1230	1200				1.4301	416587	416683					
		1230	1200				1.4404	416605	416701					
		1530	1500				1.4301	416588	416684					
		1530	1500				1.4404	416606	416702					
		2030	2000				1.4301	416589	416685					
		2030	2000				1.4404	416607	416703					
		200	170				530	500	60	142	ACO hygienic gully 157	1.4301	416590	416686
							530	500				1.4404	416608	416704
830	800			1.4301	416591	416687								
830	800			1.4404	416609	416705								
1030	1000			1.4301	416592	416688								
1030	1000			1.4404	416610	416706								
1230	1200			1.4301	416593	416689								
1230	1200			1.4404	416611	416707								
1530	1500			1.4301	416594	416690								
1530	1500			1.4404	416612	416708								
2030	2000			1.4301	416595	416691								
2030	2000			1.4404	416613	416709								
300	270			330	300	55	142	ACO hygienic gully 157				1.4301	416614	416710
				330	300							1.4404	416628	416724
		630	600	60	1.4301	416615			416711					
		630	600		1.4404	416629			416725					
		1030	1000	60	1.4301	416616			416712					
		1030	1000		1.4404	416630			416726					
		1530	1500	60	1.4301	416617			416713					
		1530	1500		1.4404	416631			416727					
		2030	2000	60	1.4301	416618			416714					
		2030	2000		1.4404	416632			416728					
		3030	3000	70	1.4301	416619			416715					
		3030	3000		1.4404	416633			416729					
		4030	4000	80	1.4301	416620			416716					
		4030	4000		1.4404	416634			416730					



ACO hygienic gully 142 → Page 22
 ACO hygienic gully 157 → Page 36
 Accessories for ACO hygienic box channel → Page 139
 Gratings for ACO hygienic box channel → Pages 126-136

Standard edge

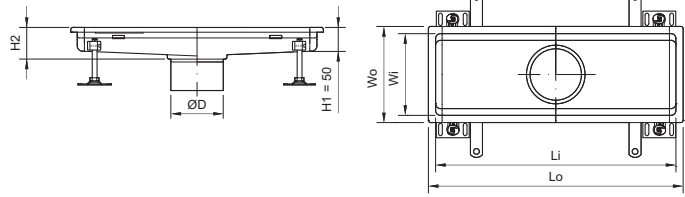

Extended edge

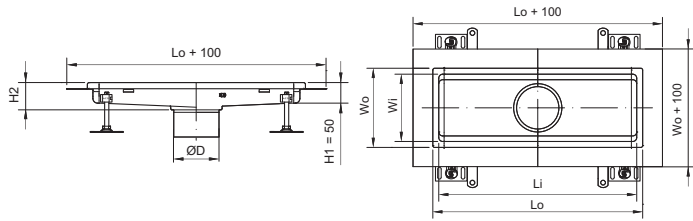

3

Channel dimensions					Gully	Material	Standard edge	Extended edge	
Wo	Wi	Lo	Li	H2			øD	Item number	Item number
[mm]	[mm]	[mm]	[mm]	[mm]	[mm]				
300	270	330	300	55	200	ACO hygienic gully 218	1.4301	416621	416717
		330	300				1.4404	416635	416731
		630	600	60			1.4301	416622	416718
		630	600				1.4404	416636	416732
		1030	1000	60			1.4301	416623	416719
		1030	1000				1.4404	416637	416733
		1530	1500	60			1.4301	416624	416720
		1530	1500				1.4404	416638	416734
		2030	2000	60			1.4301	416625	416721
		2030	2000				1.4404	416639	416735
		3030	3000	70			1.4301	416626	416722
		3030	3000				1.4404	416640	416736
		4030	4000	80			1.4301	416627	416723
		4030	4000				1.4404	416641	416737
400	370	430	400	60	142	ACO hygienic gully 157	1.4301	416642	416738
		430	400				1.4404	416648	416744
		630	600				1.4301	416643	416739
		630	600				1.4404	416649	416745
		830	800				1.4301	416644	416740
		830	800				1.4404	416650	416746

ACO hygienic gully 218 → Page 58
ACO hygienic gully 142 → Page 22

Accessories for ACO hygienic box channel → Page 139
Gratings for ACO hygienic box channel → Pages 126-136

Channel dimensions						Gully	Material	Standard edge	Extended edge
Wo [mm]	Wi [mm]	Lo [mm]	Li [mm]	H2 [mm]	øD [mm]			Item number	Item number
400	370	430	400	60	200	ACO hygienic gully 218	1.4301	416645	416741
		430	400				1.4404	416651	416747
		630	600				1.4301	416646	416742
		630	600				1.4404	416652	416748
		830	800				1.4301	416647	416743
		830	800				1.4404	416653	416749
500	470	530	500	65	142	ACO hygienic gully 157	1.4301	416654	416750
		530	500				1.4404	416660	416756
		830	800				1.4301	416655	416751
		830	800				1.4404	416661	416757
		1030	1000				1.4301	416656	416752
		1030	1000				1.4404	416662	416758
500	470	530	500	65	200	ACO hygienic gully 218	1.4301	416657	416753
		530	500				1.4404	416663	416759
		830	800				1.4301	416658	416754
		830	800				1.4404	416664	416760
		1030	1000				1.4301	416659	416755
		1030	1000				1.4404	416665	416761
600	570	630	600	70	200	ACO hygienic gully 218	1.4301	416666	416762
		630	600				1.4404	416669	416765
		930	900				1.4301	416667	416763
		930	900				1.4404	416670	416766
		1230	1200				1.4301	416668	416764
		1230	1200				1.4404	416671	416767
800	770	830	800	80	200	ACO hygienic gully 218	1.4301	416672	416768
							1.4404	416673	416769



ACO hygienic box channel semi-standard

Product information

The dimensions of the ACO hygienic box channel for concrete, tiles and resin floor can be easily specified in respect of project requirements.

Product benefits

- Hygienic design following EN 1672, EN ISO 14159 and EHEDG document No. 8, 13 and 44
- Available in 1.4301 (304) or 1.4404 (316L) grades of stainless steel
- Fully removable and easily cleanable stainless steel foul air trap (FAT)
- Rubber edge infill
- Fully pickled and passivated
- Sectional slope of the channel bottom 5°
- Longitudinal slope of the channel bottom 1-5 %
- Material thickness 1.5 mm
- Hygienic gratings with slip resistance available
- Protective cover available. See page 264 for more details
- Tested and certified according to EN 1253
- V-shape bottom for width < 300 mm
- Reinforced bottom for width > 400 mm
- Length - up to customer request
- Height - variable 50-200
- Outlet position variable in longitudinal axis
- Standardized widths
- Easy and secure telescopic connection with gully
- Adjustable EasyFix levelling feet 60-110 mm
- Anchors for fixing in concrete

3

Order information

Standard edge

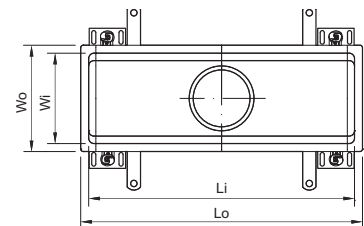
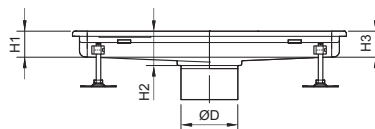

Extended edge

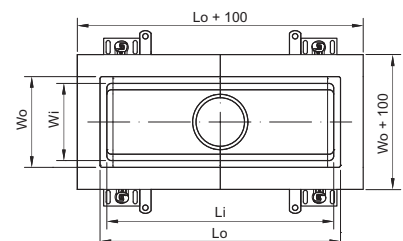
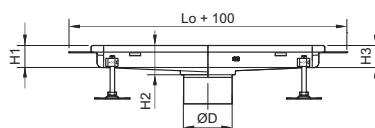

External (overall) width	Internal (grating) width	Length of channel	Height at outlet of channel	Height at end of channel
Wo [mm]	Wi [mm]	Lo	H2	H1 and H3
200	170			
300	270			
400	370	Variable*	50-200	50, 80, 110, 140
500	470			
600	570			
800	770			

In case of one piece channel requirement, channels have to be welded on site. Please contact our Sales/Technical department.

* Long channels over 6m are standard divided in 6m sections with transport joins.



ACO hygienic gully 142 → Page 22
ACO hygienic gully 157 → Page 36
ACO hygienic gully 218 → Page 58

Accessories for ACO hygienic box channel → Page 139
Gratings for ACO hygienic box channel → Pages 126-136

ACO vinyl box channel standard articles

Product information

The dimensions of the ACO vinyl box channel can be specified in respect of project requirements or easily chosen from predefined fixed dimensions.

Product benefits

- Fully compliant to EN 1253
- Material thickness 1.5 mm
- Easy and secure telescopic connection with gully
- Adjustable EasyFix levelling feet 60-110 mm
- Anchors for fixing in concrete
- Protective cover available. See page 264 for more details

Order information

Vinyl edge

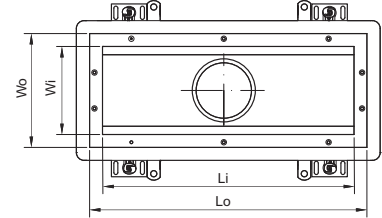
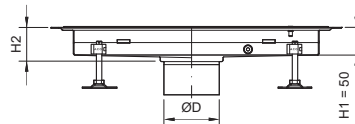

3

Channel dimensions						Gully	Material	Vinyl edge
Wo	Wi	Lo	Li	H2	øD			
[mm]	[mm]	[mm]	[mm]	[mm]	[mm]			Item number
220	170	550	500	60	125	ACO hygienic gully 142	1.4301	413358
		850	800					413359
		1050	1000					413360
		1250	1200					413361
		1550	1500					413362
		2050	2000					413363
220	170	550	500	60	142	ACO hygienic gully 157	1.4301	413364
		850	800					413365
		1050	1000					413366
		1250	1200					413367
		1550	1500					413368
		2050	2000					413369

ACO hygienic gully 142 → Page 22

Accessories for ACO hygienic box channel → Page 139
Gratings for ACO hygienic box channel → Pages 126-136

Channel dimensions						Gully	Material	Vinyl edge	
Wo	Wi	Lo	Li	H2	øD				Item number
[mm]	[mm]	[mm]	[mm]	[mm]	[mm]				
320	270	350	300	60	142	ACO hygienic gully 157	1.4301	413388	
		650	600				1.4301	413389	
		1050	1000				1.4301	413390	
		1550	1500				1.4301	413391	
		2050	2000				1.4301	413392	
		3050	3000				70	1.4301	413393
		4050	4000				80	1.4301	413394
320	270	350	300	60	200	ACO hygienic gully 218	1.4301	413395	
		650	600				1.4301	413396	
		1050	1000				1.4301	413397	
		1550	1500				1.4301	413398	
		2050	2000				1.4301	413399	
		3050	3000				70	1.4301	413400
		4050	4000				80	1.4301	413401
420	370	450	400	60	142	ACO hygienic gully 157	1.4301	413416	
		650	600				1.4301	413417	
		850	800				1.4301	413418	
520	470	450	400	65	142	ACO hygienic gully 218	1.4301	413419	
		650	600				1.4301	413420	
		850	800				1.4301	413421	
520	470	530	500	65	142	ACO hygienic gully 157	1.4301	413428	
		830	800				1.4301	413429	
		1030	1000				1.4301	413430	
520	470	550	500	65	200	ACO hygienic gully 218	1.4301	413431	
		850	800				1.4301	413432	
		1050	1000				1.4301	413433	
620	570	650	600	70	200	ACO hygienic gully 218	1.4301	413440	
		950	900				1.4301	413441	
		1250	1200				1.4301	413442	
820	770	850	800	80	200	ACO hygienic gully 218	1.4301	413446	

3

Vinyl edge

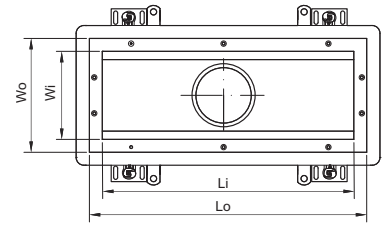
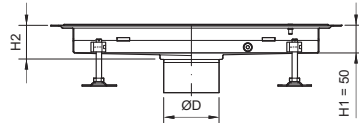

Channel dimensions						Gully	Material	Vinyl edge
W0	W1	Lo	Li	H2	øD			
[mm]	[mm]	[mm]	[mm]	[mm]	[mm]			
420	370	450	400	60	142	ACO	1.4301	413416
		650	600			hygienic gully 157	1.4301	413417
		850	800				1.4301	413418
520	470	450	400	65	142	ACO	1.4301	413419
		650	600			hygienic gully 218	1.4301	413420
		850	800				1.4301	413421
520	470	530	500	65	142	ACO	1.4301	413428
		830	800			hygienic gully 157	1.4301	413429
		1030	1000				1.4301	413430
520	470	550	500	65	200	ACO	1.4301	413431
		850	800			hygienic gully 218	1.4301	413432
		1050	1000				1.4301	413433
620	570	650	600	70	200		1.4301	413440
		950	900			ACO	1.4301	413441
		950	900			hygienic gully 218	1.4404	413444
		1250	1200				1.4301	413442
820	770	850	800	80	200	ACO hygienic gully 218	1.4301	413446

ACO vinyl box channel semi-standard

Product information

The dimensions of the ACO vinyl box channel can be easily specified in respect of project requirements.

Product benefits

- Fully compliant to EN 1253
- Available in 1.4301 (304) or 1.4404
- (316L) grades of stainless steel, pickled and passivated
- Material thickness 1.5 mm
- Height variable 50-200 mm
- Length – up to customer request
- Standardized widths
- Outlet position central or variable in longitudinal axis
- Longitudinal slopes of the channel bottom 1-5 %
- Adjustable EasyFix levelling feet 60-110 mm
- Anchors for fixing in concrete
- Protective cover available. See page 264 for more details

Order information

Vinyl edge

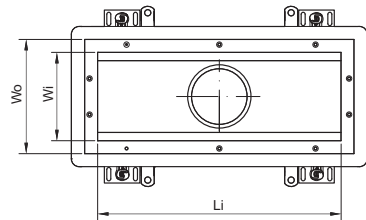
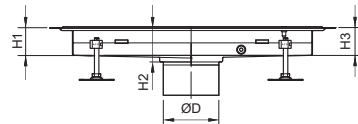

External (overall) width	Internal (grating) width	Length of channel	Height at outlet of channel	Height at end of channel
Wo [mm]	Wi [mm]		H2	H1 and H3
230	170	Variable*	50-200	50, 80, 110, 140
330	270			
430	370			
530	470			
630	570			
830	870			

In case of one piece channel requirement, channels have to be welded on site. Please contact our Sales/Technical department.

* Long channels over 6m are standard divided in 6m sections with transport joints.



ACO hygienic gully 142 → Page 22
ACO hygienic gully 157 → Page 36
ACO hygienic gully 218 → Page 58

Accessories for ACO hygienic box channel → Page 139
Gratings for ACO hygienic box channel → Pages 126-136

ACO frameless ladder grating

Product benefits

- Hygienic design following EN 1672, EN ISO 14159 and EHEDG document No. 8, 13 and 44
- Fully pickled and passivated
- Electropolished surface
- Registered logo design allows for easy manipulation during cleaning
- Range of gratings suitable for load class M 125 (EN 1253)
- High flow capacity
- Rounded corners
- Slip resistant
 - Low potential for slip according to BS 7976-2
 - R11 according to DIN 51130

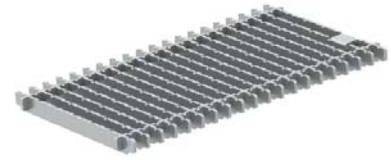

Order information

Load class M 125

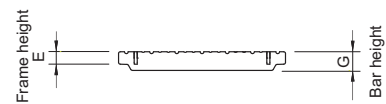
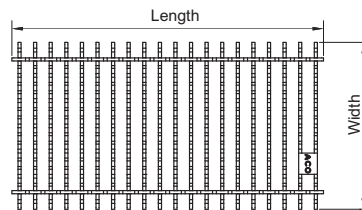
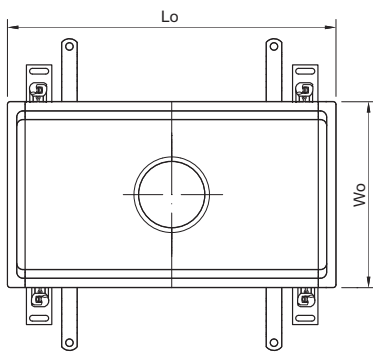

3

Channel dimension		Grating dimension			Material	Item number	Quantity to fill channel	
Wo	Lo	Frame height	Bar height	Width				Length
[mm]	[mm]	E [mm]	G [mm]	[mm]	[mm]			
200	530	20	30	168	499	1.4301	446248	1
						1.4404	446249	
	830	20	30	168	398	1.4301	446252	2
						1.4404	446253	
	1030	20	30	168	499	1.4301	446248	2
						1.4404	446249	
	1230	20	30	168	398	1.4301	446252	3
						1.4404	446253	
	1530	20	30	168	499	1.4301	446248	3
						1.4404	446249	
	2030	20	30	168	499	1.4301	446248	4
						1.4404	446249	

Channel dimension		Grating dimension				Material	Item number	Quantity to fill channel
Wo	Lo	Frame height	Bar height	Width	Length			
[mm]	[mm]	E [mm]	G [mm]	[mm]	[mm]			
300	330	20	30	268	298	1.4301	446260	1
						1.4404	446261	
	630	20	30	268	298	1.4301	446260	2
						1.4404	446261	
	1030	20	30	268	499	1.4301	446256	2
						1.4404	446257	
	1530	20	30	268	499	1.4301	446256	3
						1.4404	446257	
	2030	20	30	268	499	1.4301	446256	4
						1.4404	446257	
	3030	20	30	268	499	1.4301	446256	6
						1.4404	446257	
	4030	20	30	268	499	1.4301	446256	8
						1.4404	446257	

ACO hygienic ladder grating

Product benefits

- Hygienic design following EN 1672, EN ISO 14159 and EHEDG document No. 8, 13 and 44
- Fully pickled and passivated
- Electropolished surface
- Registered logo design allows for easy manipulation during cleaning
- Range of gratings suitable for load classes R 50, M 125 and N 250 (EN 1253)
- Tested and certified according to NSF International
- High flow capacity
- Rounded corners
- Slip resistant
 - Low potential for slip according to BS 7976-2
 - R11 according to DIN 51130



Order information

Load class R 50

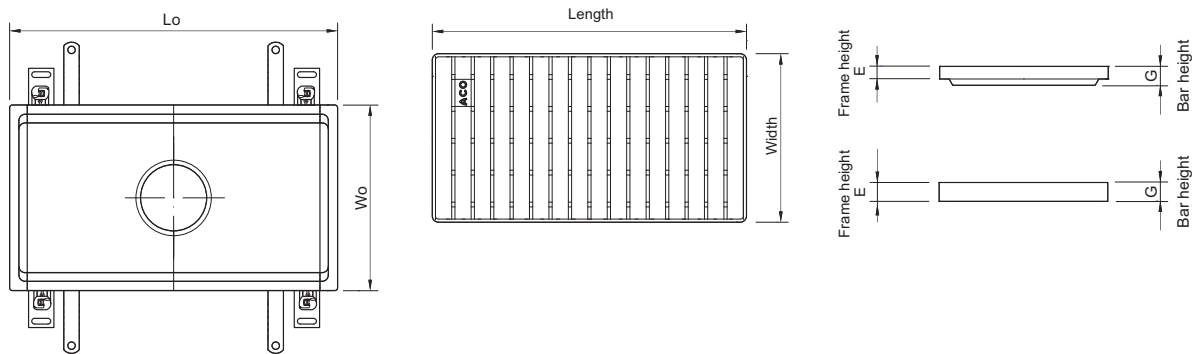

3

Channel dimension		Grating dimension			Material	Item number	Quantity to fill channel	
Wo	Lo	Frame height	Bar height	Width				Length
[mm]	[mm]	E [mm]	G [mm]	[mm]	[mm]			
200	530	20	20	168	499	1.4301	416802	1
						1.4404	416803	
	830	20	20	168	398	1.4301	416808	2
						1.4404	416809	
	1030	20	20	168	999	1.4301	445948	1
						1.4404	445949	
	1030	20	20	168	499	1.4301	416802	2
						1.4404	416803	
	1230	20	20	168	398	1.4301	416808	3
						1.4404	416809	
	1530	20	20	168	499	1.4301	416802	3
						1.4404	416803	

Channel dimension		Grating dimension				Material	Item number	Quantity to fill channel
Wo	Lo	Frame height	Bar height	Width	Length			
[mm]	[mm]	E [mm]	G [mm]	[mm]	[mm]			
200	2030	20	20	168	999	1.4301	445948	2
						1.4404	445949	
	2030	20	20	168	499	1.4301	416802	4
						1.4404	416803	
300	330	20	20	268	298	1.4301	416812	1
						1.4404	416813	
	630	20	20	268	298	1.4301	416812	2
						1.4404	416813	
	1030	20	20	268	999	1.4301	445952	1
						1.4404	445953	
	1030	20	20	268	499	1.4301	416814	2
						1.4404	416815	
	1530	20	20	268	499	1.4301	416814	3
						1.4404	416815	
	2030	20	20	268	999	1.4301	445952	2
						1.4404	445953	
	2030	20	20	268	499	1.4301	416814	4
						1.4404	416815	
	3030	20	20	268	999	1.4301	445952	3
						1.4404	445953	
3030	20	20	268	499	1.4301	416814	6	
					1.4404	416815		
4030	20	20	268	999	1.4301	445952	4	
					1.4404	445953		
4030	20	20	268	499	1.4301	416814	8	
					1.4404	416815		
400	430	30	30	368	398	1.4301	416820	1
						1.4404	416821	
	630	30	30	368	598	1.4301	416822	1
						1.4404	416823	
830	30	30	368	398	1.4301	416820	2	
					1.4404	416821		
500	530	30	30	468	499	1.4301	416828	1
						1.4404	416829	
	830	30	30	468	398	1.4301	416830	2
						1.4404	416831	
1030	30	30	468	499	1.4301	416828	2	
					1.4404	416829		

Channel dimension		Grating dimension				Material	Item number	Quantity to fill channel	
Wo	Lo	Frame height	Bar height	Width	Length				
[mm]	[mm]	E [mm]	G [mm]	[mm]	[mm]				
Load class R 50									
600	630	30	30	568	298	1.4301	416838	2	
						1.4404	416839		
	930	30	30	568	298	1.4301	416838	3	
						1.4404	416839		
	1230	30	30	568	298	1.4301	416838	4	
						1.4404	416839		
800	830	30	30	768	398	1.4301	416842	2	
						1.4404	416843		
Load class M125									
200	530	20	30	168	499	1.4301	416804	1	
						1.4404	416805		
	830	20	30	168	398	1.4301	416810	2	
						1.4404	416811		
	1030	20	20	168	999	1.4301	445950	1	
						1.4404	445951		
	1030	20	30	168	499	1.4301	416804	2	
						1.4404	416805		
	1230	20	30	168	398	1.4301	416810	3	
						1.4404	416811		
	1530	20	30	168	499	1.4301	416804	3	
						1.4404	416805		
	2030	20	20	168	999	1.4301	445950	2	
						1.4404	445951		
	2030	20	30	168	499	1.4301	416804	4	
						1.4404	416805		
	300	330	20	30	268	298	1.4301	416816	1
							1.4404	416817	
		630	20	30	268	298	1.4301	416816	2
							1.4404	416817	
		1030	20	30	268	499	1.4301	416818	2
							1.4404	416819	
		1030	20	20	268	999	1.4301	445954	1
							1.4404	445955	
1530		20	30	268	499	1.4301	416818	3	
						1.4404	416819		
2030		20	20	268	999	1.4301	445954	2	
						1.4404	445955		

Channel dimension		Grating dimension				Material	Item number	Quantity to fill channel
Wo	Lo	Frame height	Bar height	Width	Length			
[mm]	[mm]	E [mm]	G [mm]	[mm]	[mm]			
300	2030	20	30	268	499	1.4301	416818	4
						1.4404	416819	
	3030	20	30	268	999	1.4301	445954	3
						1.4404	445955	
	3030	20	30	268	499	1.4301	416818	6
						1.4404	416819	
	4030	20	20	268	999	1.4301	445954	4
						1.4404	445955	
	4030	20	30	268	499	1.4301	416818	8
						1.4404	416819	
400	430	30	30	368	398	1.4301	416824	1
						1.4404	416825	
	630	30	30	368	598	1.4301	416826	1
						1.4404	416827	
830	30	30	368	398	1.4301	416824	2	
					1.4404	416825		
500	530	30	30	468	499	1.4301	416832	1
						1.4404	416833	
	830	30	30	468	398	1.4301	416834	2
						1.4404	416835	
1030	30	30	468	499	1.4301	416832	2	
					1.4404	416833		
Load class N 250								
200	530	20	30	168	499	1.4301	416844	1
						1.4404	416845	
	830	20	30	168	398	1.4301	416846	2
						1.4404	416847	
	1030	20	30	168	499	1.4301	416844	2
						1.4404	416845	
	1230	20	30	168	398	1.4301	416846	3
						1.4404	416847	
	1530	20	30	168	499	1.4301	416844	3
						1.4404	416845	
2030	20	30	168	499	1.4301	416844	4	
					1.4404	416845		

Channel dimension		Grating dimension				Material	Item number	Quantity to fill channel
Wo	Lo	Frame height	Bar height	Width	Length			
[mm]	[mm]	E [mm]	G [mm]	[mm]	[mm]			
Load class N 250								
300	330	20	30	268	298	1.4301	416850	1
						1.4404	416851	
	630	20	30	268	298	1.4301	416850	2
						1.4404	416851	
	1030	20	30	268	499	1.4301	416848	2
						1.4404	416849	
	1530	20	30	268	499	1.4301	416848	3
						1.4404	416849	
	2030	20	30	268	499	1.4301	416848	4
						1.4404	416849	
	3030	20	30	268	499	1.4301	416848	6
						1.4404	416849	
	4030	20	30	268	499	1.4301	416848	8
						1.4404	416849	

Notes:

A large grid of dotted lines for taking notes, consisting of 20 columns and 30 rows.

ACO mesh grating

Product benefits

- ACO mesh grating with slip resistant finish
- Tested and certified according to EN 1253
- Range of gratings suitable to load class L 15 (EN 1253)
- Surface - electropolished
- High flow capacity of grates
- Rounded corners
- Slip resistant
 - Slip resistant low potential for slip according to BS 7976-2
 - R11 according to DIN 51130



Order information

Load class L 15

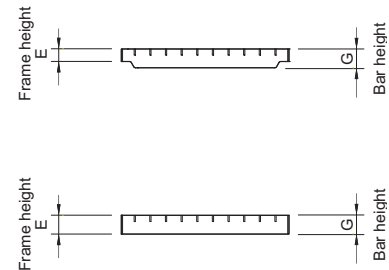
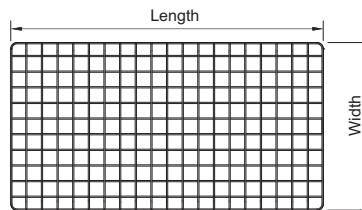
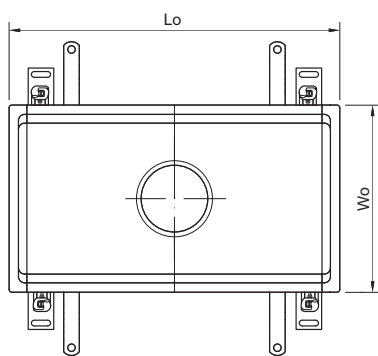

3

Channel dimension		Grating dimension				Material	Item number	Quantity to fill channel
Wo [mm]	Lo [mm]	Frame height E [mm]	Bar height G [mm]	Width [mm]	Length [mm]			
200	530	20	30	168	499	1.4301	416860	1
						1.4404	416861	
	830	20	30	168	398	1.4301	416862	2
						1.4404	416863	
	1030	20	30	168	999	1.4301	413153	1
						1.4404	445957	
	1030	20	30	168	499	1.4301	416860	2
						1.4404	416861	
	1230	20	30	168	398	1.4301	416862	3
						1.4404	416863	
	1530	20	30	168	499	1.4301	416860	3
						1.4404	416861	
	2030	20	30	168	999	1.4301	413153	2
						1.4404	445957	
	2030	20	30	168	499	1.4301	416860	4
						1.4404	416861	

Channel dimension		Grating dimension				Material	Item number	Quantity to fill channel
Wo [mm]	Lo [mm]	Frame height E [mm]	Bar height G [mm]	Width [mm]	Length [mm]			
300	330	20	30	268	298	1.4301	416864	1
						1.4404	416865	
	630	20	30	268	298	1.4301	416864	2
						1.4404	416865	
	1030	20	30	268	999	1.4301	413154	1
						1.4404	445959	
	1030	20	30	268	499	1.4301	416866	2
						1.4404	416867	
	1530	20	30	268	499	1.4301	416866	3
						1.4404	416867	
	2030	20	30	268	999	1.4301	413154	2
						1.4404	445959	
2030	20	30	268	499	1.4301	416866	4	
					1.4404	416867		
3030	20	30	268	999	1.4301	413154	3	
					1.4404	445959		
3030	20	30	268	499	1.4301	416866	6	
					1.4404	416867		
4030	20	30	268	999	1.4301	413154	4	
					1.4404	445959		
4030	20	30	268	499	1.4301	416866	8	
					1.4404	416867		
400	430	30	30	368	398	1.4301	416868	1
						1.4404	416869	
	630	30	30	368	598	1.4301	416870	1
						1.4404	416871	
500	830	30	30	368	398	1.4301	416868	2
						1.4404	416869	
	530	30	30	468	499	1.4301	416872	1
						1.4404	416873	
830	30	30	468	398	1.4301	416874	2	
					1.4404	416875		
600	1030	30	30	468	499	1.4301	416872	2
						1.4404	416873	
	630	30	30	568	298	1.4301	416876	2
						1.4404	416877	
930	30	30	568	298	1.4301	416876	3	
					1.4404	416877		
1230	30	30	568	298	1.4301	416876	4	
					1.4404	416877		
800	830	30	30	768	398	1.4301	416878	2
						1.4404	416879	



ACO hygienic slot cover

Product benefits

- Hygienic design following EN 1672, EN ISO 14159 and EHEDG document No. 8, 13 and 44
- Fully pickled and passivated
- Sandblasted surface
- Range of gratings suitable for load classes R 50, M 125 and N 250 (EN 1253)
- Rounded corners
- Slip resistant
 - Low potential for slip according to BS 7976-2
 - R11 according to DIN 51130

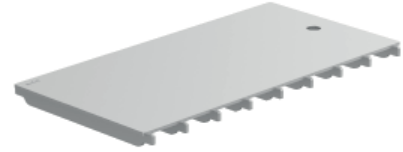

Order information

Load class R 50

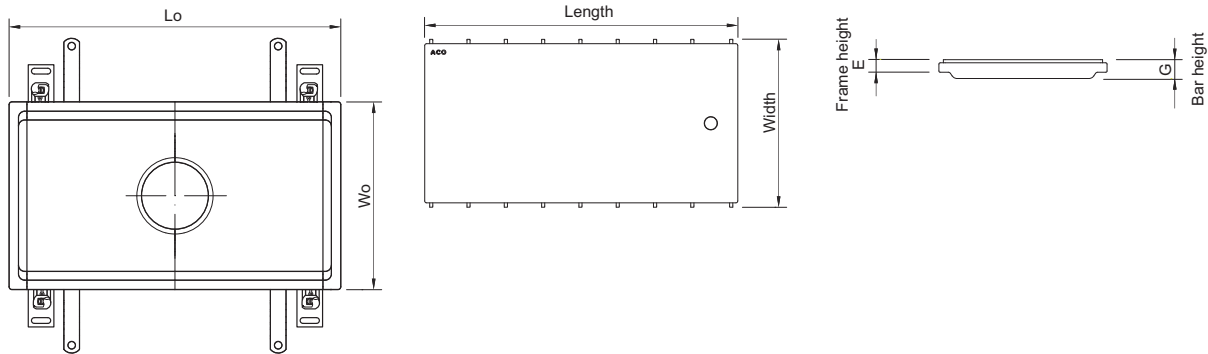

3

Channel dimension		Grating dimension		Material	Item number	Quantity to fill channel		
Wo [mm]	Lo [mm]	Frame height E [mm]	Bar height G [mm]				Width [mm]	Length [mm]
200	530	20	30	168	499	1.4301	445756	1
						1.4404	445757	
	830	20	30	168	398	1.4301	445762	2
						1.4404	445763	
	1030	20	30	168	499	1.4301	445756	2
						1.4404	445757	
	1230	20	30	168	398	1.4301	445762	3
						1.4404	445763	
	1530	20	30	168	499	1.4301	445756	3
						1.4404	445757	
	2030	20	30	168	499	1.4301	445756	4
						1.4404	445757	

Channel dimension		Grating dimension		Material	Item number	Quantity to fill channel		
Wo [mm]	Lo [mm]	Frame height E [mm]	Bar height G [mm]				Width [mm]	Length [mm]
300	330	20	30	268	298	1.4301	445774	1
						1.4404	445775	
	630	20	30	268	298	1.4301	445774	2
						1.4404	445775	
	1030	20	30	268	499	1.4301	445768	2
						1.4404	445769	
	1530	20	30	268	499	1.4301	445768	3
						1.4404	445769	
	2030	20	30	268	499	1.4301	445768	4
						1.4404	445769	
	3030	20	30	268	499	1.4301	445768	6
						1.4404	445769	
Load class M 125								
200	530	20	30	168	499	1.4301	445758	1
						1.4404	445759	
	830	20	30	168	398	1.4301	445764	2
						1.4404	445765	
	1030	20	30	168	499	1.4301	445758	2
						1.4404	445759	
	1230	20	30	168	398	1.4301	445764	3
						1.4404	445765	
	1530	20	30	168	499	1.4301	445758	3
						1.4404	445759	
	2030	20	30	168	499	1.4301	445758	4
						1.4404	445759	
300	330	20	30	268	298	1.4301	445776	1
						1.4404	445777	
	630	20	30	268	298	1.4301	445776	2
						1.4404	445777	
	1030	20	30	268	499	1.4301	445770	2
						1.4404	445771	
	1530	20	30	268	499	1.4301	445770	3
						1.4404	445771	
	2030	20	30	268	499	1.4301	445770	4
						1.4404	445771	
	3030	20	30	268	499	1.4301	445770	6
						1.4404	445771	

Channel dimension		Grating dimension				Material	Item number	Quantity to fill channel
Wo [mm]	Lo [mm]	Frame height E [mm]	Bar height G [mm]	Width [mm]	Length [mm]			
Load class N 250								
200	530	20	30	168	499	1.4301	445760	1
						1.4404	445761	
	830	20	30	168	398	1.4301	445766	2
						1.4404	445767	
	1030	20	30	168	499	1.4301	445760	2
						1.4404	445761	
	1230	20	30	168	398	1.4301	445766	3
						1.4404	445767	
	1530	20	30	168	499	1.4301	445760	3
						1.4404	445761	
	2030	20	30	168	499	1.4301	445760	4
						1.4404	445761	
300	330	20	30	268	298	1.4301	445778	1
						1.4404	445779	
	630	20	30	268	298	1.4301	445778	2
						1.4404	445779	
	1030	20	30	268	499	1.4301	445772	2
						1.4404	445773	
	1530	20	30	268	499	1.4301	445772	3
						1.4404	445773	
	2030	20	30	268	499	1.4301	445772	4
						1.4404	445773	
	3030	20	30	268	499	1.4301	445772	6
						1.4404	445773	

Accessories for ACO box channels

Order information

Silt baskets for ACO hygienic box channel

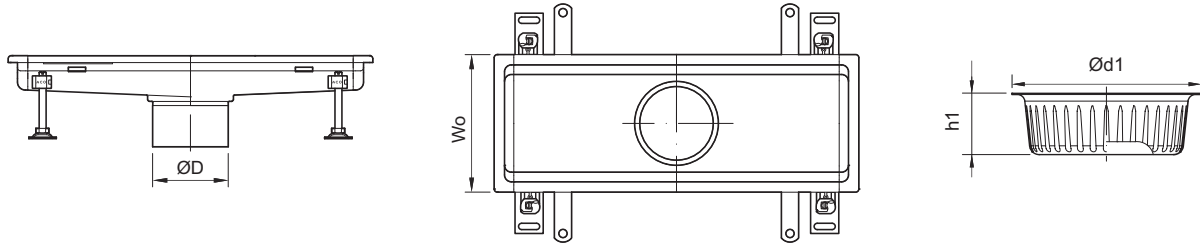

Channel dimension	Outlet	Direction of gully outlet	Silt basket dimension		Capacity	Material	Item number		
Width W_o [mm]	$\varnothing D$ [mm]		$\varnothing d1$ [mm]	$h1$ [mm]	[l]				
200, 300, 400, 500, 600, 800	125	vertical, horizontal	142	45	0.4	1.4301	416900		
						1.4404	416901		
200	142	vertical	142	45	0.4	1.4301	416900		
						1.4404	416901		
		horizontal	142	25	0.3	1.4301	416902		
						1.4404	416903		
300, 400, 500, 600, 800	142 or welded with ACO hygienic gully 157	vertical	159	50	0.6	1.4301	416904		
						1.4404	416905		
		horizontal	159	26	0.3	1.4301	416906		
						1.4404	416907		
		300, 400, 500, 600, 800	200 or welded with ACO hygienic gully 218	vertical	222	50	1.4	1.4301	416908
								1.4404	416909
horizontal	222			26	0.7	1.4301	416910		
						1.4404	416911		

ACO customized box channel

Product information

The dimensions of the ACO customized box channel for concrete, tiles and resin floor can be easily specified in respect of project requirements.

Product benefits

- Material thickness 1.5 mm or 2 mm
- Width – up to customer request
- Length – up to customer request
- Depth – up to customer request
- Variable shape of channel – T shape, L shape
- Longitudinal slopes of the channel bottom 1-5 %
- Outlet position central or variable in longitudinal axis or eccentric outlet
- Adjustable EasyFix levelling feet
- Anchors for fixing in concrete
- Protective cover available for recommended channel widths. See page 264 for more details

Instructions

- Please define channel dimensions by filling out required entry fields
- For technical support, please contact **customerservice@aco.cz**
- For Industrial Drainage information, visit **www.buildingdrainage.aco**
- These option buttons highlight hygienic design requirements
- These option buttons highlight possible conflicts in hygienic design

Step 1 - Material

Stainless steel grade 1.4301 (AISI 304)

Stainless steel grade 1.4404 (AISI 316L)

Step 2 - Edge profile

Standard edge

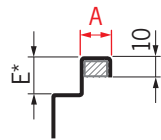

Extended edge

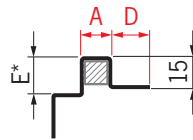

L-profile edge

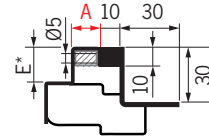

Edge infill type

Rubber edge infill

PUR edge infill

Steel edge infill

No edge infill

Edge infill type

Rubber edge infill

PUR edge infill

Steel edge infill

No edge infill

Edge infill type

Rubber edge infill

PUR edge infill

Steel edge infill

No edge infill

Edge width (A)

15 mm

Custom: ** mm

Edge width (A)

15 mm

Custom: ** mm

Edge width (A)

15 mm

Custom: ** mm

Flange length (D)

50 mm

Custom: mm

Read more about L-profile edge at:
www.buildingdrainage.aco

* Sitting height for gratings (E) is defined in step 7

** For hygienic solution, check with technical support

Step 2 - Edge profile

Folded edge

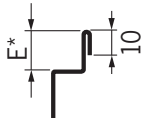

Folded edge with flange

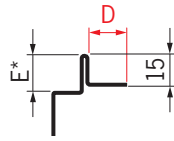

Flange length (D)

50 mm

Custom: mm

Vinyl edge

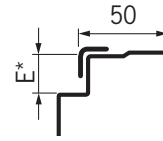

Step 3 - Channel dimensions

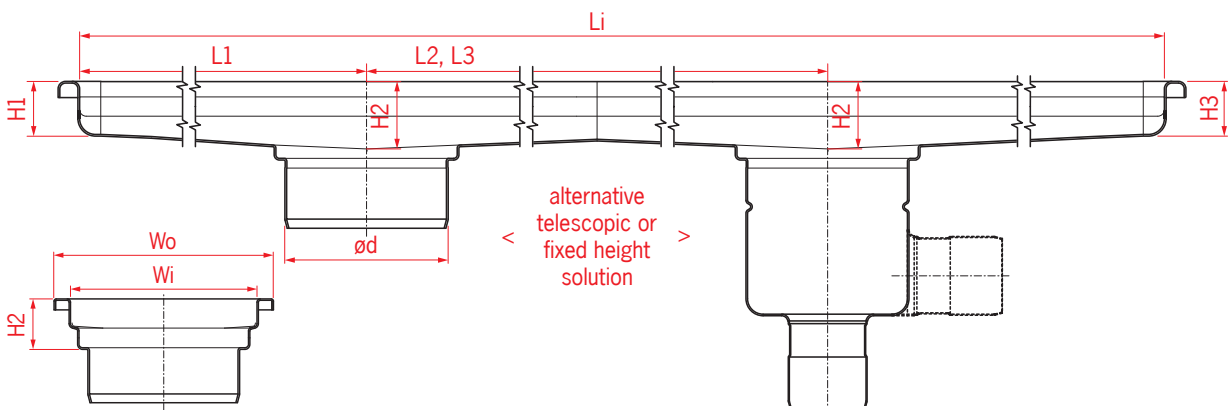

Width	Channel height at outlet	Channel length	Channel shape
Overall (Wo) / Internal (Wi)	(H2)	(Li)	

150 mm / 118 mm
(valid for edge width 15 mm)

mm

mm

L-shape

200 mm / 170 mm
(valid for edge width 15 mm)

Slope

Number of outlets and their spacing (L1-L4)***

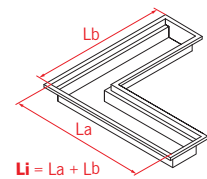

300 mm / 270 mm
(valid for edge width 15 mm)

No

L1: mm

400 mm / 370 mm
(valid for edge width 15 mm)

Yes - 1%

L2: mm

La: mm

500 mm / 470 mm
(valid for edge width 15 mm)

Yes - height defined**

L3: mm

600 mm / 570 mm
(valid for edge width 15 mm)

H1: mm

L4: mm

Lb: mm

800 mm / 770 mm
(valid for edge width 15 mm)

H3: mm

T-shape

Custom*:

Wo: mm

Wi: mm

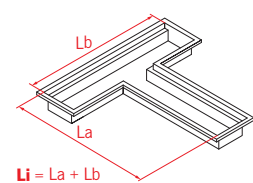

La: mm

Lb: mm

* For channel with standard edge width of 15 mm subtract 30 mm from overall width as value for internal width

** If you require values below 50 mm, please contact technical support

*** For hygienic solution, check with technical support



Step 4 - Gully construction

Welded gully

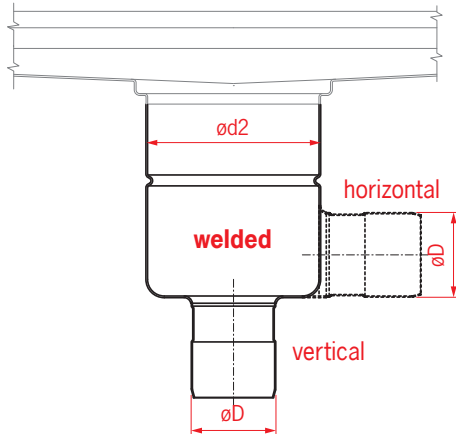

Telescopic gully

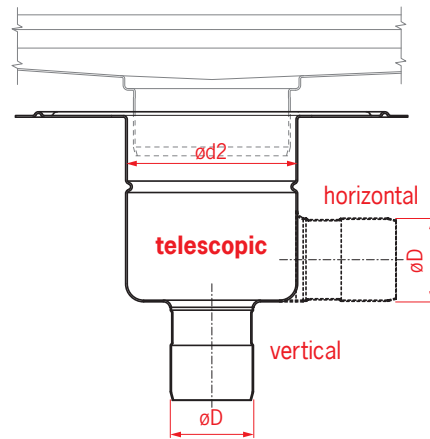

Outlet orientation and dimensions

Vertical outlet

($\varnothing d2$ / $\varnothing D$)

Horizontal outlet

($\varnothing d2$ / $\varnothing D$)

142 / 75 (1.4 l/s)

142 / 75 (1.4 l/s)

142 / 110 (1.6 l/s)

142 / 110 (1.6 l/s)

157 / 75 (2.7 l/s)

157 / 75 (2.6 l/s)

157 / 110 (3.5 l/s)

157 / 110 (2.8 l/s)

218 / 110 (5.0 l/s)

218 / 110 (4.4 l/s)

218 / 160 (5.0 l/s)

Location flange
(For telescopic gully only)



Bonding flange
(For telescopic gully only)



Mechanical clamping flange
(For telescopic gully only)



Without gully (outlet pipe only)

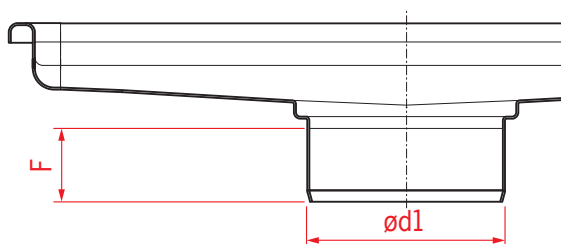

Outlet diameter

($\varnothing d1$)

Outlet length

(F)

75 mm

36 mm

110 mm

58 mm

125 mm

150 mm

142 mm

Custom: mm

200 mm

Step 5 - Accessories

Foul air trap included



- Yes
 No

Silt basket included



- Yes
 No

Raising piece included

- Yes
 No

With Location flange

With Bonding flange

With Mechanical clamping flange



ACO EasyFix

levelling feet height (H)

- 80 mm (standard)
 110 mm
 170 mm
 200 mm
 250 mm
 300 mm

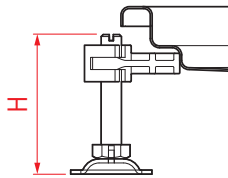

Channel with height at outlet above 200 mm are supplied with durable stainless steel levelling feet

ACO Protective cover

covers included

- Yes
 No



Step 6 - Delivery requirements

Maximum transport length

(Lt)

- 6000 mm (standard)
 3000 mm
 2000 mm

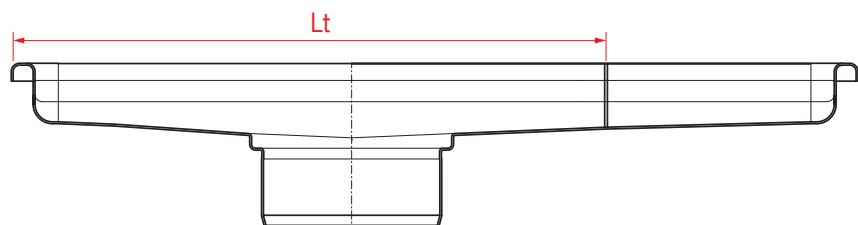

Transport connection type

- Welded on site Bolted on site

Step 7 - Gratings

- ACO frameless ladder grating ACO hygienic ladder grating ACO mesh grating



Slip resistant



Slip resistant Plain



Slip resistant Plain

Load class

- M 125**
(valid up to $W_o = 300$ mm)

- R 50**
(valid up to $W_o = 800$ mm)

- M 125**
(valid up to $W_o = 500$ mm)

- N 250**
(valid up to $W_o = 300$ mm)

- P 400**
(Custom)

Load class

- L 15**
(valid up to $W_o = 1000$ mm)

- R 50** max. $W_o = 300$
(valid up to $W_o = 500$ mm)

- M 125** max. $W_o = 300$
(valid up to $W_o = 300$ mm)

- ACO hygienic slot cover



Slip resistant

- ACO perforated grating



Plain

- ACO heelsafe grating

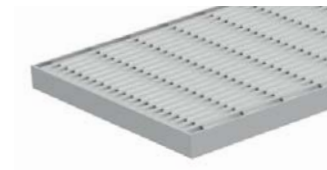

Plain

Load class

- R 50**
(valid up to $W_o = 300$ mm)

- M125**
(valid up to $W_o = 300$ mm)

- M 250**
(valid up to $W_o = 300$ mm)

- L 15**
(valid up to $W_o = 300$ mm)

- R 50** max. $W_o = 300$
(valid up to $W_o = 300$ mm)

- L 15** max. $W_o = 300$
(valid up to $W_o = 300$ mm)

ACO multi-slot 5 grating

Without gratings



Slip resistant

Height of gratings (E)

20 mm

25 mm

30 mm

40 mm

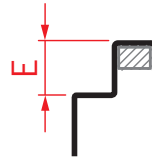

- ┌ ┐ **L 15**
- └ ┘ (valid up to $W_o = 300$ mm)
- ┌ ┐ **R 50** max. $W_o = 300$
- └ ┘ (valid up to $W_o = 300$ mm)

Introduction to ACO slot channel

ACO slot channel portfolio

The ACO slot channel range covers channels for all common applications and all common floor types (concrete, tiles, resin or vinyl).

Selecting a channel from the range is easy. The unique variability of the whole portfolio allows choosing the right channel according to all customers' needs.

Channel's length, depth and outlet position are just a few of the parameters which can be varied and, regardless of the variations specified, there is no impact on delivery lead times.

ACO slot channel ordering

The dimensions of the ACO slot channel can be easily specified in respect of project requirements.

To specify the channel please use the Customization template (see page 149) which will help you to identify the information needed or contact our Sales/Technical department.

ACO slot channel customization

In addition all ACO slot channel can be designed with:

- Special outlet position
- Special depth
- Special slope
- Special slot channel width
- L-shape and T-shape layout
- Special side inlets

To request customised ACO slot channel, please contact our Sales/technical department.

ACO slot channel system overview

ACO slot channel, fixed height solution



ACO slot channel, telescopic solution



3

ACO slot channel semi-standard

Product information

The dimensions of the ACO slot channel for concrete, tiles and resin floor can be easily specified in respect of project requirements.

Product benefits

- Tested and certified according to EN 1253
- Available in 1.4301 (304) or 1.4404 (316L) grades of stainless steel, pickled and passivated
- 1.5 mm material thickness
- ACO slot channel 8 or 20 mm
- Length – up to customer request
- Longitudinal slopes of the channel bottom 1-5 %
- Standardized widths
- Outlet position central or variable in longitudinal axis
- Adjustable EasyFix levelling feet
- Anchors for fixing in concrete
- Protective cover available. See page 264 for more details

Order information

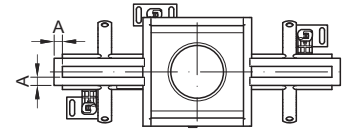
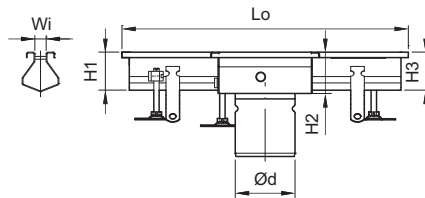

External (overall) width	Dimension of edge	Length of channel	Height at outlet of channel	Height at end of channel
Wi [mm]	A [mm]	Lo	H2	H1 and H3
20	15	Variable*	50-200	50-200
8	folded		50-200	50-200

* The maximum transportable length of channel is 6 000 mm.
Long channels over 6 000 mm are standardly divided in 6 m sections with transport joints.

ACO customized slot channel

Product information

The dimensions of the ACO customized slot channel for concrete, tiles and resin floor can be easily specified in respect of project requirements.

Product benefits

- Tested and certified according to EN 1253
- 1.5 mm material thickness
- Slot of channel 8 or 20
- Length – up to customer request
- Longitudinal slopes of the channel bottom 1-5 %
- Outlet position central or variable in longitudinal axis
- Adjustable EasyFix levelling feet
- Anchors for fixing in concrete
- Protective covers available for gully tops. See page 264 for more details

Instructions

- Please define channel dimensions by filling out required entry fields
- For technical support, please contact customerservice@aco.cz
- For Industrial Drainage information, visit www.buildingdrainage.aco

Hygienic design principles don't apply to slot channels.

Step 1 - Material

Stainless steel grade 1.4301 (AISI 304)

Stainless steel grade 1.4404 (AISI 316L)

Step 2 - Edge profile



Detail of the Edge profile

Standard edge

Extended edge

Folded edge

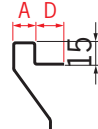
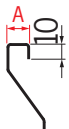

Edge infill type

Rubber edge infill

PUR edge infill

Steel edge infill

No edge infill

Edge infill type

Rubber edge infill

PUR edge infill

Steel edge infill

No edge infill

Edge width (A)

15 mm

25 mm

Edge width (A)

15 mm

25 mm

Flange length (D)

50 mm

Custom: mm

Step 2 - Edge profile

Folded edge with flange

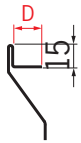

Flange length (D)



50 mm



Custom: mm

Vinyl edge



Step 3 - Channel dimensions

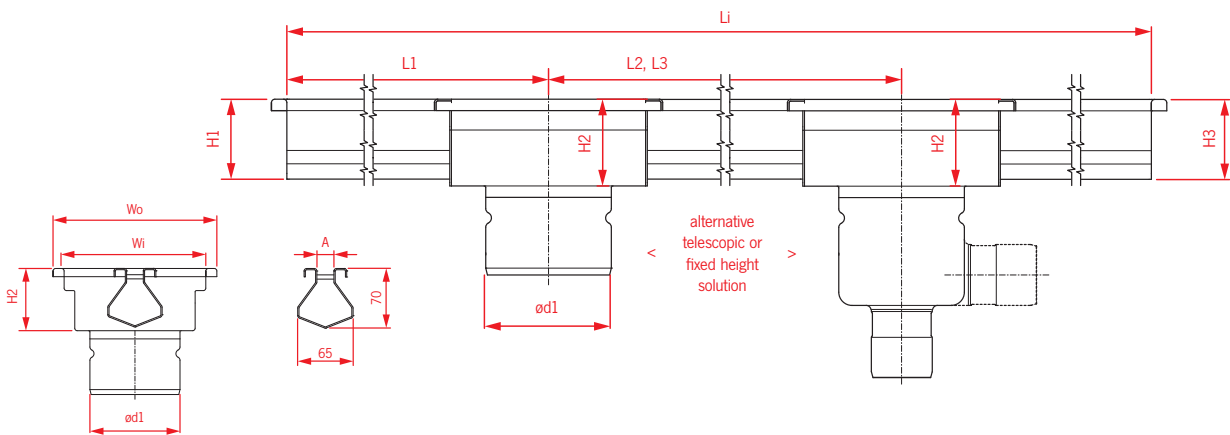

Gully top dimensions

Gully top (Wo) / Outlet (ød2)



200 x 200 mm / 75 mm
(valid for edge width 15 mm)



200 x 200 mm / 110 mm
(valid for edge width 15 mm)



200 x 200 mm / 125 mm
(valid for edge width 15 mm)



250 x 250 mm / 142 mm
(valid for edge width 15 mm)



300 x 300 mm / 200 mm
(valid for edge width 15 mm)



Custom*:

Wo: mm

Wi: mm

Slot width

(A)



8 mm



20 mm

Channel height at outlet

(H2)

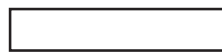

Slope



No



Yes - 1%



Yes - height defined**

H1: mm

H3: mm

Channel length

(L1)



Number of outlets and their spacing (L1-L4)***



L1: mm



L2: mm



L3: mm



L4: mm

* For gully top with standard edge width of 15 mm subtract 30 mm from overall width as value for internal width

** If you require values below 50 mm, please contact technical support

*** For higher number of outlets, please contact technical support

Step 4 - Gully construction

Welded gully

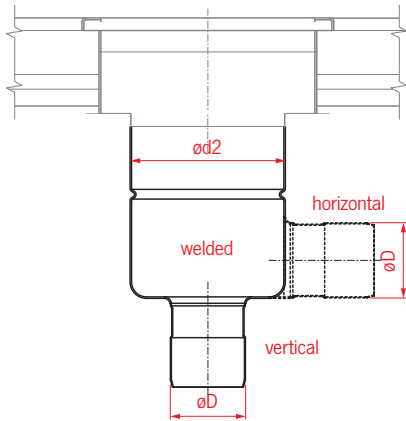

Telescopic gully

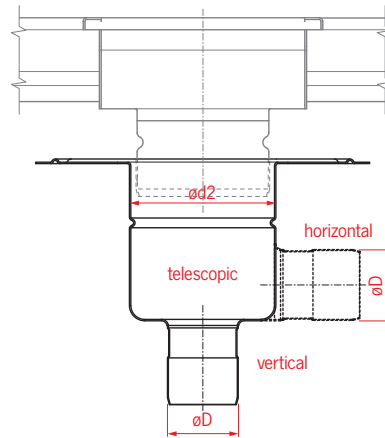

Outlet orientation and dimensions

Vertical outlet ($\varnothing d2$ / $\varnothing D$)	Horizontal outlet ($\varnothing d2$ / $\varnothing D$)
---	---

142 / 75 (1.4 l/s) 142 / 75 (1.4 l/s)

142 / 110 (1.6 l/s) 142 / 110 (1.6 l/s)

157 / 75 (2.7 l/s) 157 / 75 (2.6 l/s)

157 / 110 (3.5 l/s) 157 / 110 (2.8 l/s)

218 / 110 (5.0 l/s) 218 / 110 (4.4 l/s)

218 / 160 (5.0 l/s)

Location flange
(For telescopic gully only)



Bonding flange
(For telescopic gully only)



Mechanical clamping flange
(For telescopic gully only)



Without gully (outlet pipe only)

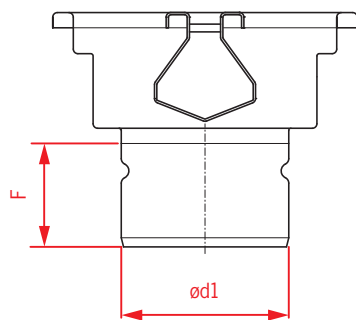

Outlet diameter ($\varnothing d1$)	Outlet length (F)
---	----------------------

75 mm
(valid for gully top 200 x 200 mm)

36 mm

110 mm
(valid for gully top 200 x 200 mm)

58 mm

125 mm
(valid for gully top 200 x 200 mm)

150 mm

142 mm
(valid for gully top 250 x 250 mm)

Custom: mm

200 mm
(valid for gully top 300 x 300 mm)

Step 5 - Accessories

Foul air trap included



- Yes
 No

Silt basket included



- Yes
 No

Raising piece included

- Yes
 No

With Location flange

With Bonding flange

With Mechanical clamping flange



ACO EasyFix

levelling feet height (H)

- 80 mm (standard)
 110 mm
 170 mm
 200 mm

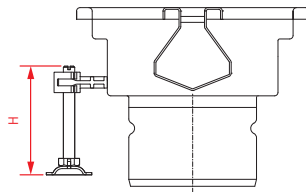

ACO Protective

covers included

- Yes
 No



Step 6 - Delivery requirements

Maximum transport length

(Lt)

- 6000 mm (standard)
 3000 mm
 2000 mm

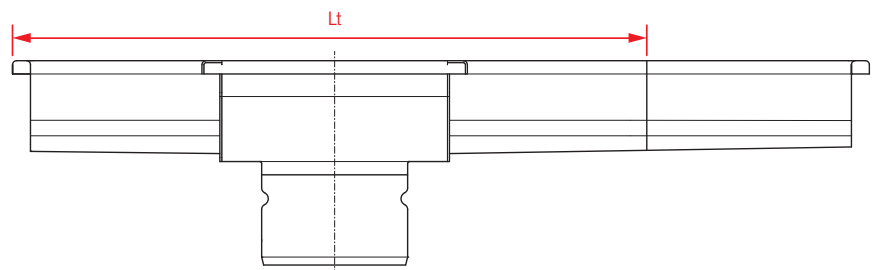

Step 7 - Gratings

- ACO frameless ladder grating** **ACO hygienic ladder grating** **ACO mesh grating**



- Slip resistant Plain



- Slip resistant Plain



- Slip resistant Plain

Load class

- | | | |
|---|---|--|
| <input type="checkbox"/> M 125
(valid up to $W_o = 300$ mm) | <input type="checkbox"/> R 50
(valid up to $W_o = 300$ mm) | <input type="checkbox"/> L 15
(valid up to $W_o = 300$ mm) |
| | <input type="checkbox"/> M 125
(valid up to $W_o = 300$ mm) | <input type="checkbox"/> R 50
(valid up to $W_o = 300$ mm) |
| | <input type="checkbox"/> N 250
(valid up to $W_o = 300$ mm) | |

- ACO hygienic slot cover** **ACO perforated grating** **ACO multi-slot 5 grating**



Slip resistant

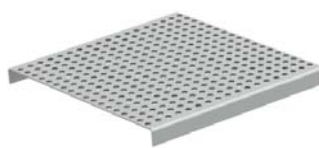

Plain



Slip resistant

Load class

- | | | |
|---|--|--|
| <input type="checkbox"/> M 125
(valid up to $W_o = 300$ mm) | <input type="checkbox"/> L 15
(valid up to $W_o = 300$ mm) | <input type="checkbox"/> L 15
(valid up to $W_o = 300$ mm) |
| | <input type="checkbox"/> R 50
(valid up to $W_o = 300$ mm) | <input type="checkbox"/> R 50
(valid up to $W_o = 300$ mm) |

- ACO heelsafe grating** **Without grating**



Plain

Height of gratings (E)

- 20 mm
- 25 mm
- 30 mm
- 40 mm

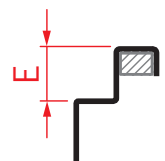

Load class

- L 15**
(valid up to $W_o = 300$ mm)

Introduction to ACO modular channel

ACO modular channel portfolio

The ACO modular channel range includes channels for all common applications and all common floor types (concrete, tiles, resin or vinyl).

Selecting a channel from the range is easy. The unique variability of the whole portfolio makes it easy to choose the right channel according to a specific customer's needs.

Channel's length, depth and outlet position are just a few of the parameters which can be varied and, regardless of the variations specified, there is no impact on delivery lead times.

ACO modular channel ordering

The dimensions of the ACO modular channel can be easily specified in respect of project requirements.

ACO modular channel customization

In addition, all ACO modular channels can be designed to a special length.

To request customised ACO modular channel, please contact our Sales/ Technical department.

3

ACO modular sloped channel connection

Sloped channels are provided with rubber seal at the deep end of the channel only.

If your design plan includes channels connection at shallow ends, make sure that appropriate amount of rubber seals is included in your order.

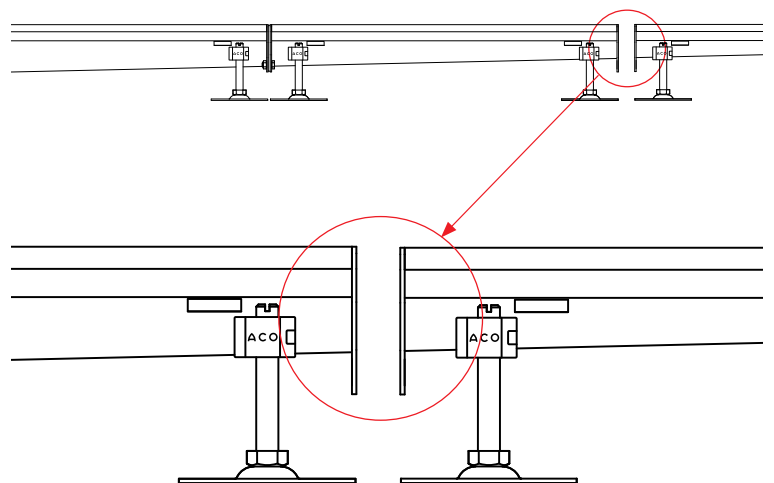

ACO modular channel system overview



ACO modular box channel 125



ACO modular box channel 200



ACO modular slot channel 20



**ACO gully
with accessories**

ACO modular box channel system overview

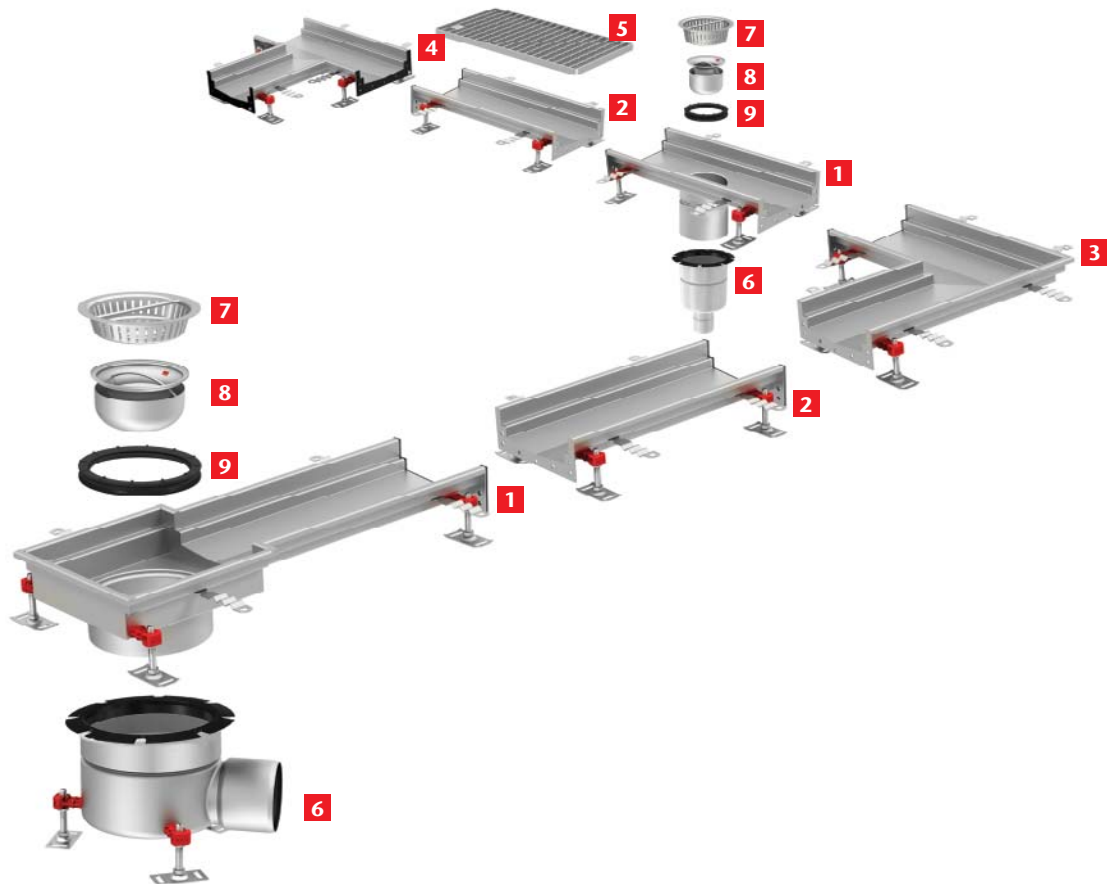

3

- | | |
|--|--------------------------------|
| 1 Outlet unit | 6 Gully |
| 2 Level invert and sloping invert channel | 7 Silt basket |
| 3 Corner unit | 8 Foul air trap |
| 4 Branch unit | 9 Foul air trap support |
| 5 Grating | |

ACO modular slot channel system overview

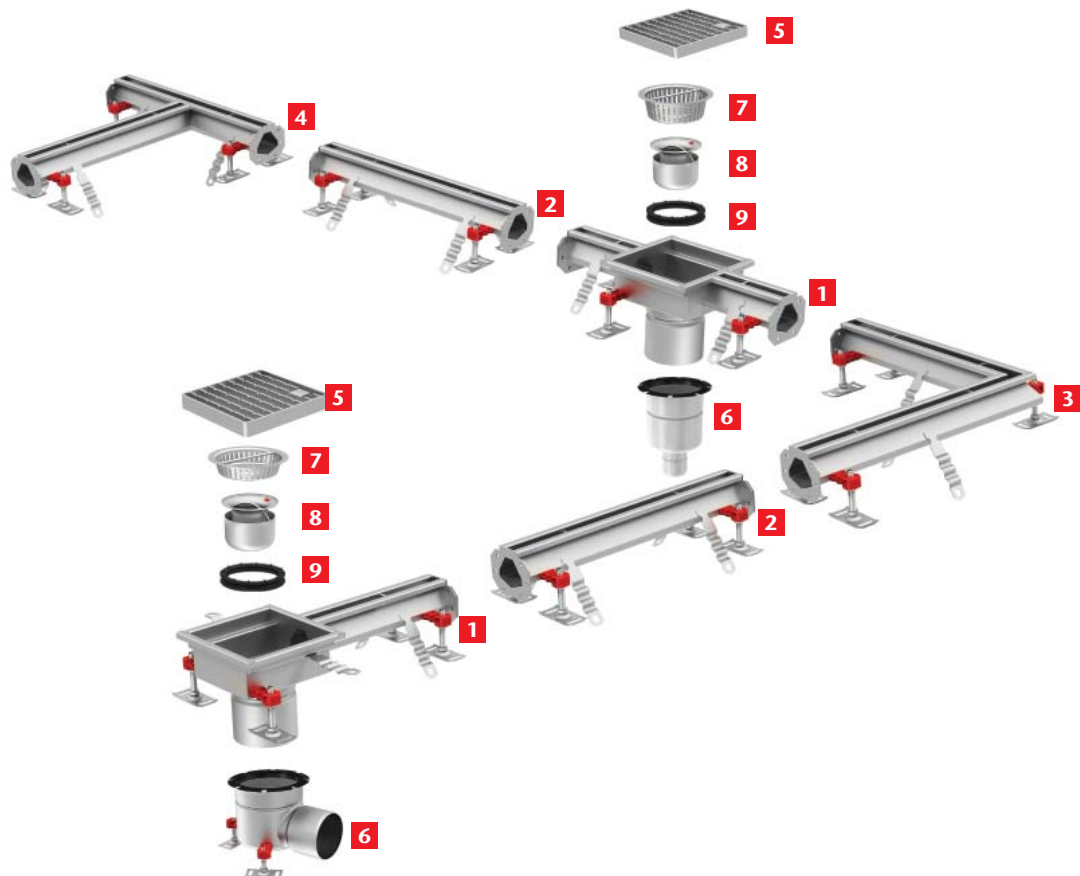

- | | | | |
|----------|---|----------|-----------------------|
| 1 | Outlet unit | 6 | Gully |
| 2 | Level invert and sloping invert channel | 7 | Silt basket |
| 3 | Corner unit | 8 | Foul air trap |
| 4 | Branch unit | 9 | Foul air trap support |
| 5 | Grating | | |

ACO modular box channel 125 standard articles

Product information

Modular concept allows specification of standard channel units to surround machinery and fit within existing tiling patterns.

Vee-bottomed (V) profiled channel for enhanced flow efficiency at low flow rates and for improved self cleaning performance.

Product benefits

- Fully compliant to EN 1253
- Fully tested and classified to EN 1433
- Available in 1.4301 (304) or 1.4404 (316L) grades of stainless steel
- Fully pickled and passivated
- Easy and secure telescopic connection with gully
- Cut on demand items available to minimize works on site
- Wide range of gratings for load class up to C 250 (EN 1433)

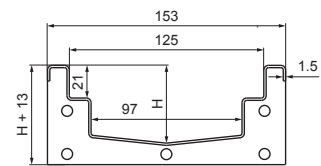

Order information

Level invert channel

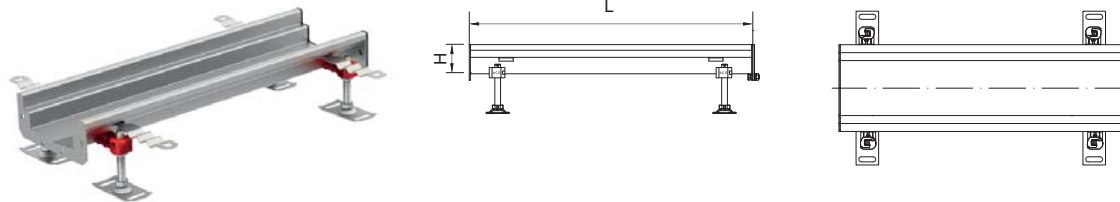

Dimensions

Item number

L [mm]	Dimensions		Item number	
	L [mm]	H [mm]	1.4301	1.4404
500		50	105119	407211
		65	105120	407212
		80	105121	407213
		95	105122	407214
		110	105123	407215
		125	105124	407216
1000		50	105127	407217
		65	105128	407218
		80	105129	407219
		95	105130	407220
		110	105131	407221
		125	105132	407222
2000		50	105135	407223
		65	105136	407224
		80	105137	407225
	95	105138	407226	

Gratings for ACO modular box channel 125 → Page 164

L [mm]	Dimensions		Item number	
	H [mm]	1.4301	1.4404	
2000	110	105139	407227	
	125	105140	407228	
	50	105143	407229	
	65	105144	407230	
3000	80	105145	407231	
	95	105146	407232	
	110	105147	407233	
	125	105148	407234	

Note: Items are equipped with seal and connecting material on one side.

Sloping invert channel

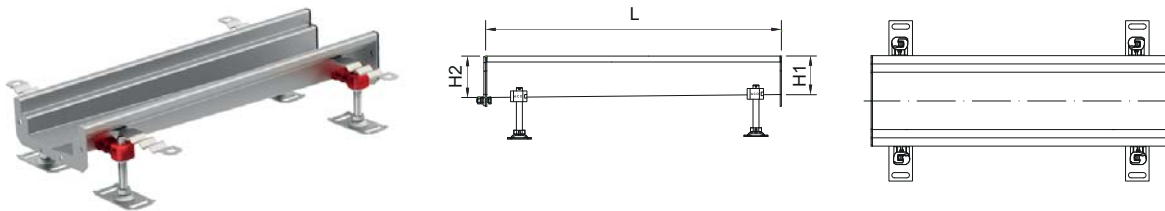

L [mm]	Dimensions		Item number	
	H1 [mm]	H2 [mm]	1.4301	1.4404
500	50	65	105151	407235
	65	80	105152	407236
1000	50	65	105155	407237
	65	80	105156	407238
	80	95	105157	407239
	95	110	105158	407240
2000	50	65	105161	407241
	65	80	105162	407242
	80	95	105163	407243
	95	110	105164	407244
3000	110	125	105165	407245
	50	65	105168	407246
	65	80	105169	407247
	80	95	105170	407248
6000	95	110	105171	407249
	110	125	105172	407250
	50	80	408821	408824
6000	65	95	408822	408825
	95	125	408823	408826

Note: Items are equipped with seal and connecting material on deeper side only. See page 148 for more details.

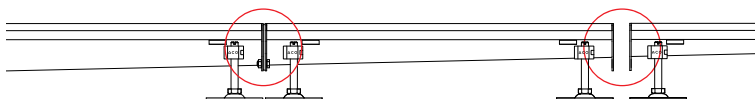

Corner unit

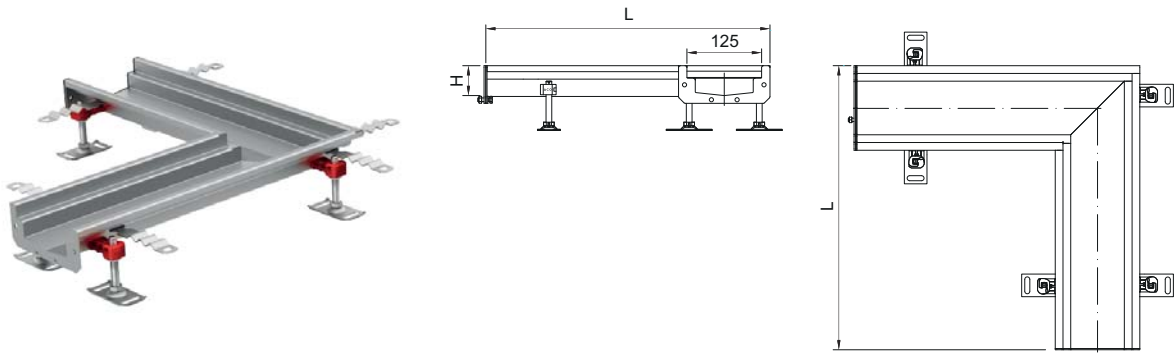

Dimensions		Item number	
L [mm]	H [mm]	1.4301	1.4404
515	50	409812	409818
	65	409813	409819
	80	409814	409820
	95	409815	409821
	110	409816	409822
	125	409817	409823

Note: Items are equipped with seal and connecting material on one side.

Branch unit

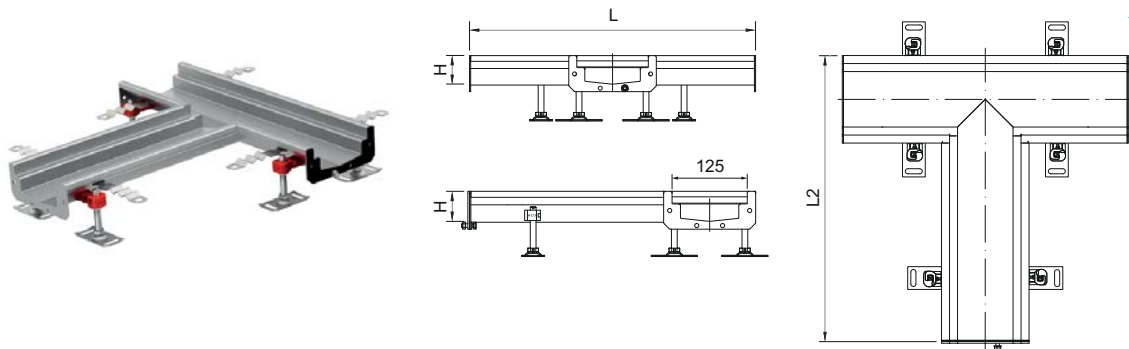

Dimensions			Item number	
L1 [mm]	L2 [mm]	H [mm]	1.4301	1.4404
500	515	50	409824	409830
		65	409825	409831
		80	409826	409832
		95	409827	409833
		110	409828	409834
		125	409829	409835

Note: Items are equipped with seal and connecting material on one side.

End outlet

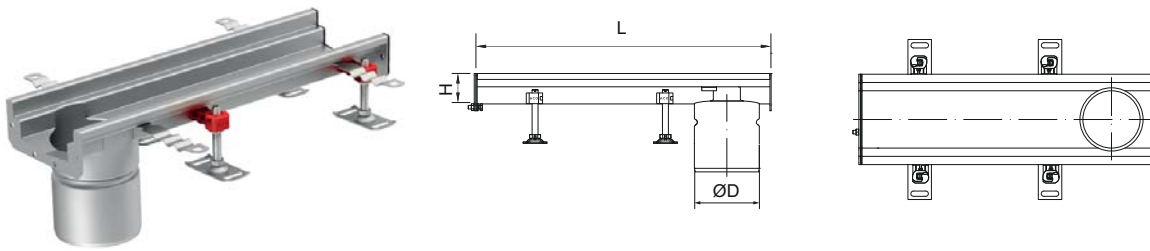

Dimensions		Gully	Outlet diameter øD [mm]	Item number			
L [mm]	H [mm]			1.4301	1.4404		
500	50	ACO gully EG150	110	105175	407251		
	65			105176	407252		
	80			105177	407253		
	95			105178	407254		
	110			105179	407255		
	125			105180	407256		
1000	50			105183	407257		
	65			105184	407258		
	80			105185	407259		
	95			105186	407260		
	110			105187	407261		
	125			105188	407262		
500	50			ACO hygienic gully 142	125	415946	415991
	65					415947	415992
	80					415948	415993
	95					415949	415994
	110					415950	415995
	125					415951	415996
1000	50	415952	415997				
	65	415953	415998				
	80	415954	415999				
	95	415955	416000				
	110	415956	416001				
	125	415957	416002				
500	50	ACO hygienic gully 157	142			409732	409733
	65					409736	409737
	80					409740	409741
	95					409744	409745
	110					409724	409725
	125					409728	409729
1000	50			409708	409709		
	65			409712	409713		
	80			409716	409717		
	95			409720	409721		
	110			409700	409701		
	125			409704	409705		

Note: Items are equipped with seal and connecting material on one side.



ACO hygienic gully 142 → Page 22
ACO hygienic gully 157 → Page 36
ACO hygienic gully 218 → Page 58

ACO gully EG150 → Page 80 / Accessories → Page <?>
Gratings for ACO modular box channel 125 → Page 164
Accessories for ACO modular box channel 125 → Page 169



Centre outlet

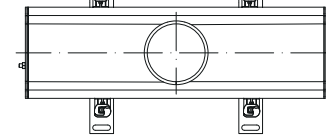
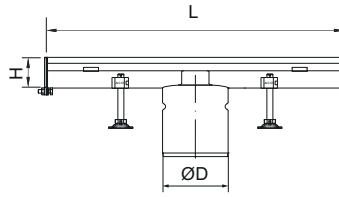

Dimensions		Gully	Outlet diameter øD [mm]	Item number	
L [mm]	H [mm]			1.4301	1.4404
500	50	ACO gully EG150	110	105191	407263
	65			105192	407264
	80			105193	407265
	95			105194	407266
	110			105195	407267
	125			105196	407268
1000	50			105199	407269
	65			105200	407270
	80			105201	407271
	95			105202	407272
	110			105203	407273
	125			105204	407274
500	50	ACO hygienic gully 142	125	415958	416003
	65			415959	416004
	80			415960	416005
	95			415961	416006
	110			415962	416007
	125			415963	416008
1000	50			415964	416009
	65			415965	416010
	80			415966	416011
	95			415967	416012
	110			415968	416013
	125			415969	416014
500	50	ACO hygienic gully 157	142	409734	409735
	65			409738	409739
	80			409742	409743
	95			409746	409747
	110			409726	409727
	125			409730	409731
1000	50			409710	409711
	65			409714	409715
	80			409718	409719
	95			409722	409723
	110			409702	409703
	125			409706	409707

Note: Items are equipped with seal and connecting material on one side.

ACO gully EG150 → Page 80 / Accessories → Page <?>
ACO hygienic gully 142 → Page 22
ACO hygienic gully 157 → Page 36

Gratings for ACO modular box channel 125 → Page 164
Accessories for ACO modular box channel 125 → Page 169

End plate

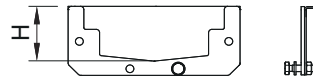

Dimensions	Item number	
	1.4301	1.4404
H [mm]		
50	105100	407196
65	105101	407197
80	105102	407198
95	105103	407199
110	105104	407200
125	105105	407201

Note: Items include seal and connecting material.

End plate with 50 mm outlet

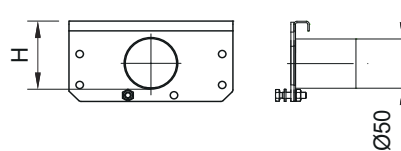

Dimensions	Item number	
	1.4301	1.4404
H [mm]		
65	409114	409119
80	409115	409120
95	409116	409121
110	409117	409122
125	409118	409123

Note: Items include seal and connecting material.

Seal rubber

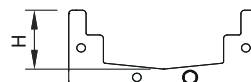

Dimensions	Item number
	NBR
H [mm]	
50	413587
65	413588
80	413589
95	413590
110	413591
125	413592

Note: Items include seal and connecting material.

3

Gratings for ACO modular box channel 125

Product benefits

- Fully tested and classified to EN 1433
- Slip resistant gratings available for added user safety
- Special length 375 mm for branches and corner units
- Load classes A 15, B 125 and C 250

Order information

ACO frameless ladder grating

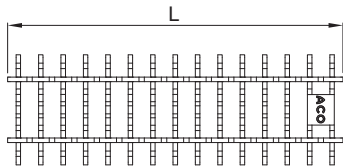

Length L [mm]	Load class	Slip resistant	Material	Item number
375	C 250	Yes	1.4301	446280
			1.4404	446281
500	C 250	Yes	1.4301	446276
			1.4404	446277

ACO ladder grating

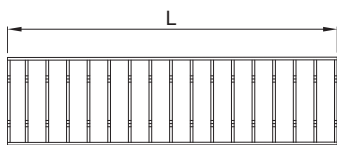

Length L [mm]	Load class	Slip resistant	Material	Item number
375	C 250	Yes	1.4301	414134
			1.4404	414184
500	C 250	Yes	1.4301	21740
			1.4404	21745
1000	C 250	Yes	1.4301	21741
			1.4404	21746

ACO mesh grating

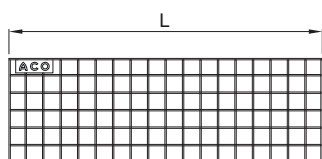

Length L [mm]	Load class	Slip resistant	Material	Item number
375	A 15	No	1.4301	414132
			1.4404	414182
	C 250	Yes	1.4301	414130
			1.4404	414180
	C 250	No	1.4301	414133
			1.4404	414183
500	A 15	No	1.4301	21720
			1.4404	21725
	C 250	Yes	1.4301	21710
			1.4404	21715
	C 250	No	1.4301	21920
			1.4404	21925
1000	A 15	Yes	1.4301	21910
			1.4404	21915
	C 250	No	1.4301	21620
			1.4404	21625
	C 250	Yes	1.4301	21610
			1.4404	21615
C 250	No	1.4301	21820	
		1.4404	21825	
C 250	Yes	1.4301	21810	
		1.4404	21815	

ACO heelsafe grating

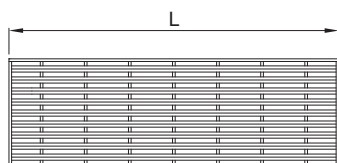

Length L [mm]	Load class	Slip resistant	Material	Item number
375	B 125	No	1.4301	414135
			1.4404	414185
500	B 125	No	1.4301	96819
			1.4404	401238
1000	B 125	No	1.4301	96818
			1.4404	401237

ACO perforated grating

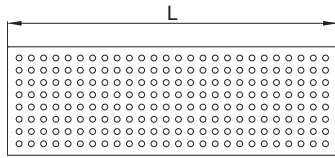

Length L [mm]	Load class	Slip resistant	Locking	Material	Item number
375	A 15	No	No	1.4301	414136
			No	1.4404	414186
	B 125	No	No	1.4301	414137
			No	1.4404	414187
500	A 15	No	Yes	1.4301	21760
			No	1.4404	21765
			No	1.4301	447612
			No	1.4404	447613
	B 125	No	Yes	1.4301	21960
			No	1.4404	21965
			No	1.4301	447614
			No	1.4404	447615
1000	A 15	No	Yes	1.4301	21660
			No	1.4404	21665
			No	1.4301	447616
			No	1.4404	447617
	B 125	No	Yes	1.4301	21860
			No	1.4404	21865
			No	1.4301	447618
			No	1.4404	447619

3

ACO quadrato grating

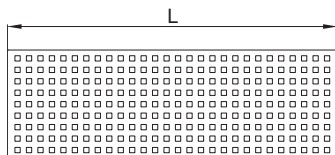

Length L [mm]	Load class	Slip resistant	With lock	Material	Item number
375	A 15	No	No	1.4301	414138
			No	1.4404	414188
500	A 15	No	No	1.4301	105530
			No	1.4404	413999
			Yes	1.4301	105528
			Yes	1.4404	407925
1000	A 15	No	No	1.4301	105529
			No	1.4404	413998
			Yes	1.4301	105527
			Yes	1.4404	407924

ACO multi-slot 5 grating

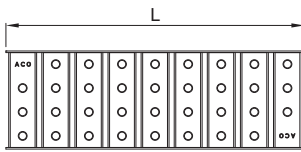

Length L [mm]	Load class	Slip resistant	Material	Item number
375	A 15	Yes	1.4301	414139
			1.4404	414189
500	A 15	Yes	1.4301	409290
			1.4404	409291
1 000	A 15	Yes	1.4301	409286
			1.4404	409287

ACO multi-slot 8 grating



Length L [mm]	Load class	Slip resistant	Material	Item number
500	A 15	Yes	1.4301	415739
			1.4404	415740
	B 125	Yes	1.4301	415747
			1.4404	415748
	C 250	Yes	1.4301	415753
			1.4404	415754
1 000	A 15	Yes	1.4301	415735
			1.4404	415736
	B 125	Yes	1.4301	415743
			1.4404	415744
	C 250	Yes	1.4301	415751
			1.4404	415752

ACO hygienic slot cover

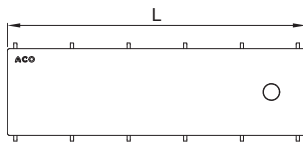

Length L [mm]	Load class	Slip resistant	Material	Item number
375	B 125	Yes	1.4301	445800
			1.4404	445801
	C 250	Yes	1.4301	445802
			1.4404	445803
500	B 125	Yes	1.4301	445792
			1.4404	445793
	C 250	Yes	1.4301	445794
			1.4404	445795
1 000	B 125	Yes	1.4301	445796
			1.4404	445797
	C 250	Yes	1.4301	445798
			1.4404	445799

ACO plastic grating

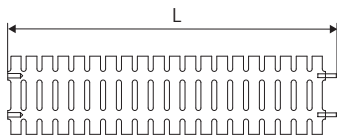

Length L [mm]	Load class	Slip resistant	Material	Item number
500	A 15	No	-	21790
1000	A 15	No	-	21690

Accessories for ACO modular box channel 125

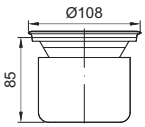
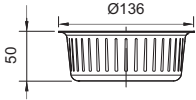
	Description	Used with	Material	Item number
	Sieve ■ Stainless steel	■ ACO modular box channel 125 with outlet 110 mm	1.4301	97235
			1.4404	97285
	Foul air trap ■ Stainless steel ■ Water seal 50 mm	■ ACO modular box channel 125 with outlet 110 mm	1.4301	97217
			1.4404	97267
	Silt basket ■ Stainless steel ■ 0.5 litre capacity	■ ACO modular box channel 125 with outlet 125 and 142 mm	1.4301	414339
			1.4404	414340

ACO modular box channel 200 standard articles

Product information

Modular concept allows specification of standard channel units to surround machinery and fit within existing tiling patterns.

Product benefits

- Fully compliant to EN 1253
- Fully tested and classified to EN 1433
- Fully pickled and passivated
- Easy and secure telescopic connection with gully
- Cut on demand items available to minimize works on site
- Wide range of gratings for load class up to C 250 (EN 1433)

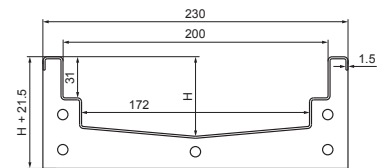

Order information

Level invert channel

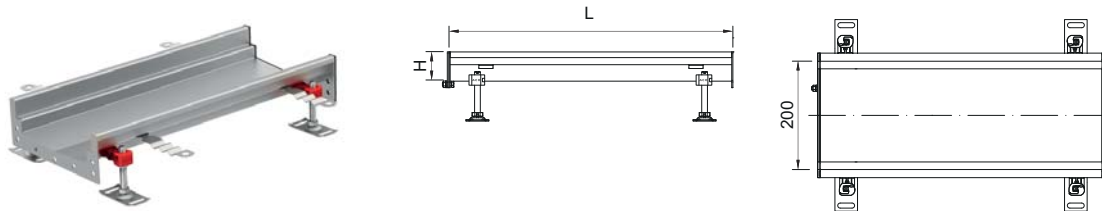

Dimensions

Item number

L [mm]	H [mm]	1.4301	1.4404
500	60	409072	409050
	70	409047	409051
	80	409048	409052
	100	409049	409053
1000	60	401859	401860
	70	409054	409057
	80	409055	409058
	100	409056	409059
2000	60	401875	401876
	70	409060	409063
	80	409061	409064
	100	409062	409065
3000	60	401895	401896
	70	409066	409069
	80	409067	409070
	100	409068	409071

Note: Items are equipped with seal and connecting material on one side.

Gratings for ACO modular box channel 200 → Page 178

Sloping invert channel

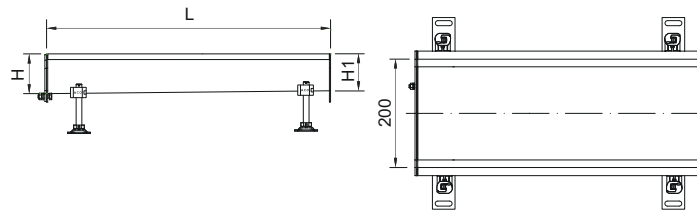

L [mm]	Dimensions		Item number	
	H1 [mm]	H2 [mm]	1.4301	1.4404
500	55	60	401855	401856
	60	70	401871	401872
	70	80	402464	402465
1000	80	90	402466	402467
	90	100	402468	402469
	100	110	402470	402471
	60	70	401887	401888
	70	80	402472	402473
2000	80	90	402474	402475
	90	100	402476	402477
	100	110	402478	402479
	110	120	402480	402481
	60	80	402482	402483
3000	80	100	402484	402485
	100	120	402486	402487
	120	140	402488	402489
6000	60	100	408827	408829
	100	140	408828	408830

Note: Items are equipped with seal and connecting material on deeper side only. See page 146 for more details.

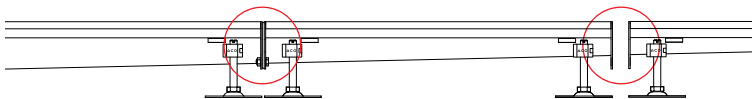

Corner unit

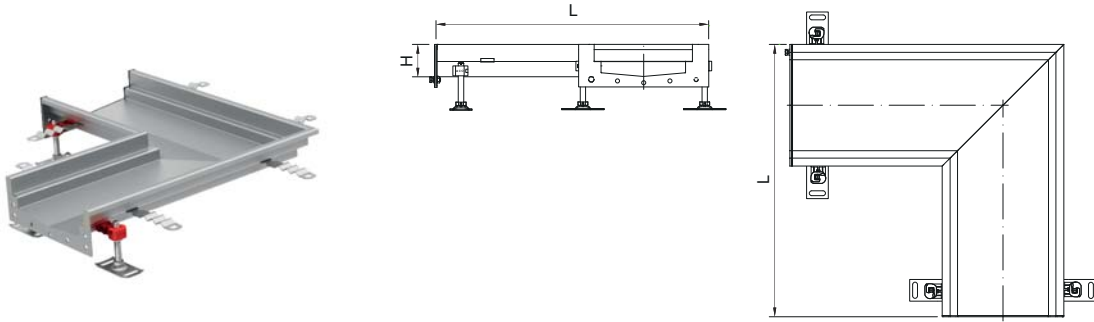

L [mm]	Dimensions		Item number	
	H [mm]	1.4301	1.4404	
515	60	401921	401922	
	80	402490	402491	
	100	402492	402493	

Note: Items are equipped with seal and connecting material on one side.

Branch unit

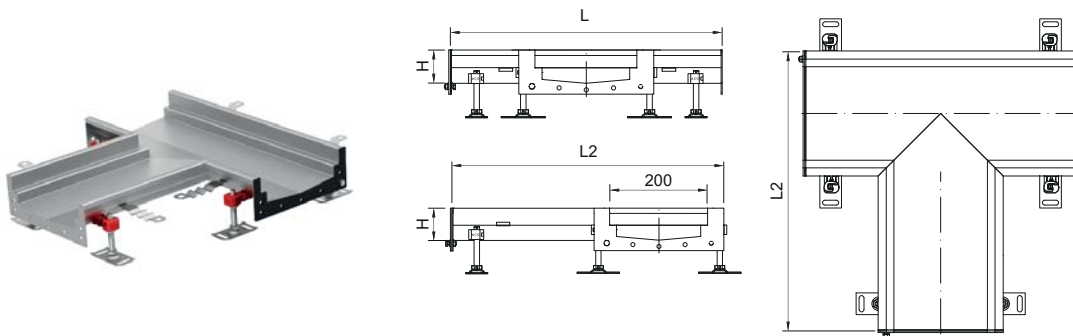

L [mm]	Dimensions			Item number	
	H1 [mm]	H2 [mm]	1.4301	1.4404	
500	515	60	401933	401934	
		80	402494	402495	
		100	402496	402497	

Note: Items are equipped with seal and connecting material on one side.

End outlet

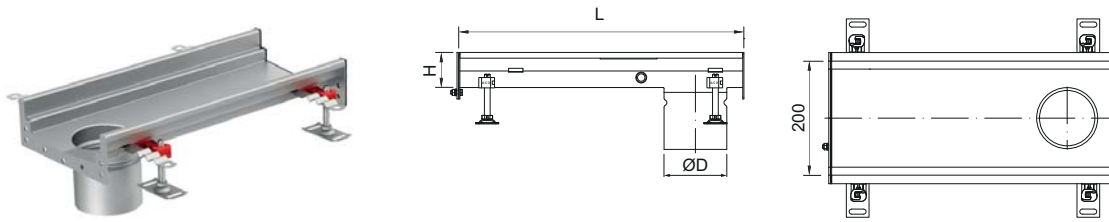

Dimensions		Gully	Outlet diameter øD [mm]	Item number	
L [mm]	H [mm]			1.4301	1.4404
500	60	ACO gully EG150	110	414275	414283
	70			414276	414284
	80			414277	414285
	90			414278	414286
	100			414279	414287
	110			414280	414288
	120			414281	414289
	140			414282	414290
1000	60			414291	414299
	70			414292	414300
	80			414293	414301
	90			414294	414302
	100			414295	414303
	110			414296	414304
500	120	414297	414305		
	140	414298	414306		
	60	ACO hygienic gully 157	142	409900	409908
	70			409901	409909
	80			409902	409910
	90			409903	409911
	100			409904	409912
110	409905			409913	
120	409906			409914	
1000	140			409907	409915
	60			409932	409940
	70			409933	409941
	80			409934	409942
	90			409935	409943
	100			409936	409944
	110			409937	409945
1000	120	409938	409946		
	140	409939	409947		

Note: Items are equipped with seal and connecting material on one side.



End outlet

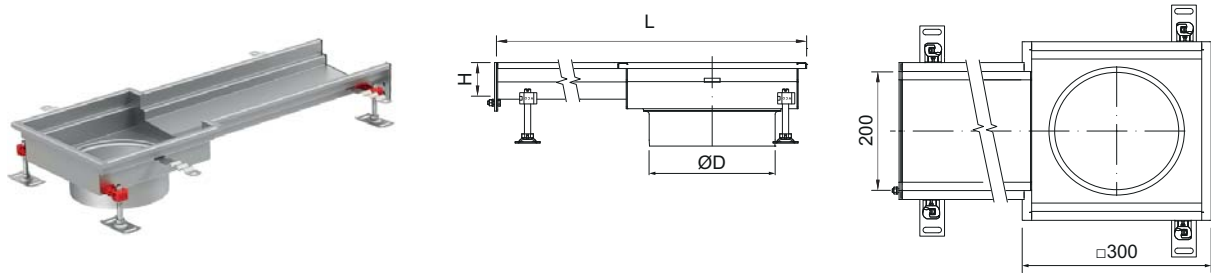

Dimensions		Gully	Outlet diameter	Item number	
L [mm]	H [mm]			1.4301	1.4404
785	60	ACO hygienic gully 218	200	414259	414267
	70			414260	414268
	80			414261	414269
	90			414262	414270
	100			414263	414271
	110			414264	414272
	120			414265	414273
	140			414266	414274

Note: Items are equipped with seal and connecting material on one side.

Centre outlet

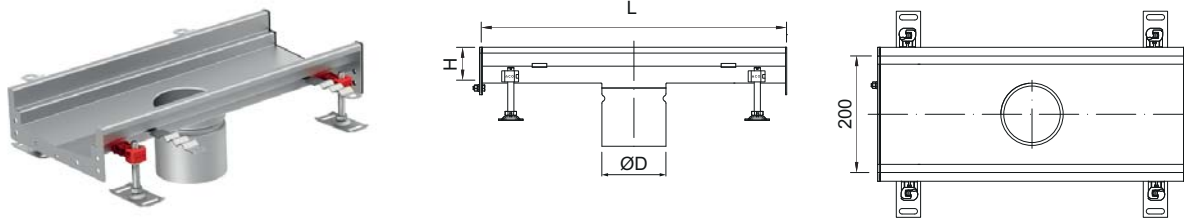

Dimensions		Gully	Outlet diameter øD [mm]	Item number	
L [mm]	H [mm]			1.4301	1.4404
500	60	ACO gully EG150	110	414307	414315
	70			414308	414316
	80			414309	414317
	90			414310	414318
	100			414311	414319
	110			414312	414320
	120			414313	414321
	140			414314	414322
1000	60			414323	414331
	70			414324	414332
	80			414325	414333
	90			414326	414334
	100			414327	414335
	110			414328	414336
	120			414329	414337
	140			414330	414338
500	60	ACO hygienic gully 157	142	409916	409924
	70			409917	409925
	80			409918	409926
	90			409919	409927
	100			409920	409928
	110			409921	409929
	120			409922	409930
	140			409923	409931
1000	60			409948	409956
	70			409949	409957
	80			409950	409958
	90			409951	409959
	100			409952	409960
	110			409953	409961
	120			409954	409962
	140			409955	409963

Note: Items are equipped with seal and connecting material on one side.

3

Centre outlet

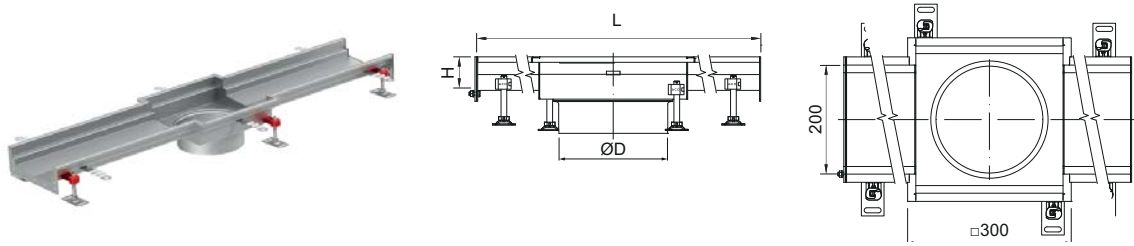

Dimensions		Gully	Outlet diameter ØD [mm]	Item number	
L [mm]	H [mm]			1.4301	1.4404
1270	60	ACO hygienic gully 218	200	414243	414251
	70			414244	414252
	80			414245	414253
	90			414246	414254
	100			414247	414255
	110			414248	414256
	120			414249	414257
	140			414250	414258

Note: Items are equipped with seal and connecting material on one side.

End plate

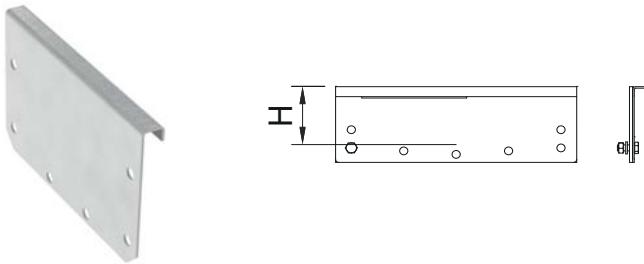

Dimensions [mm]	Item number	
	1.4301	1.4404
55	402683	402684
60	402028	402029
70	402030	402031
80	402514	402515
90	402032	402033
100	402516	402517
110	402518	402519
120	402036	402037
140	402520	402521

Note: Items are equipped with seal and connecting material.

End plate with 50 mm outlet

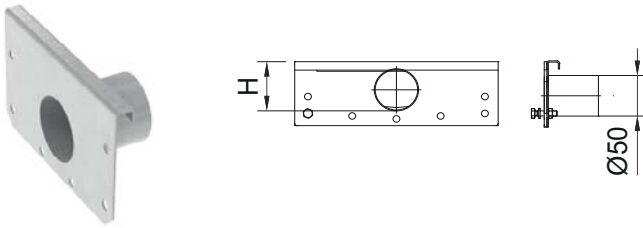

Dimensions	Item number	
	1.4301	1.4404
H [mm]		
55	402001	402002
60	402003	402004
70	402005	402006
80	402034	402035
90	402007	402008
100	402024	402025
110	402020	402021
120	402022	402023
140	401999	402000

Note: Items are equipped with seal and connecting material.

Seal rubber



Dimensions	Item number	
	NBR	
H [mm]		
60	413593	
70	413594	
80	413595	
90	413596	
100	413597	
110	413598	
120	413599	
140	413600	

Note: Items are equipped with seal and connecting material.

Gratings for ACO modular box channel 200

Product benefits

- Fully tested and classified to EN 1433
- Slip resistant gratings available for added user safety
- Special length 300 mm for branches and corner units
- Load classes A 15, B 125 and C 250

Order information

ACO frameless ladder grating

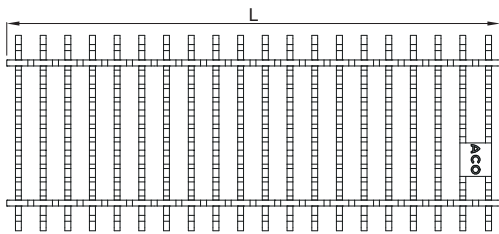

Length L [mm]	Load class	Slip resistant	Material	Item number
300	C 250	Yes	1.4301	446288
			1.4404	446289
500	C 250	Yes	1.4301	446284
			1.4404	446285

ACO ladder grating

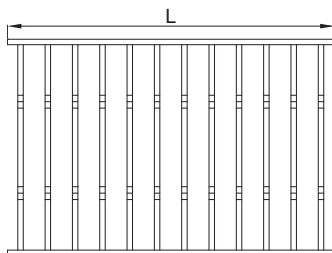

Length L [mm]	Load class	Slip resistant	Material	Item number
300	C 250	Yes	1.4301	414142
			1.4404	414192
500	C 250	Yes	1.4301	92214
			1.4404	92264
1000	C 250	Yes	1.4301	92215
			1.4404	92265

ACO mesh grating

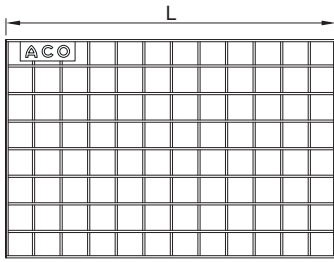

Length L [mm]	Load class	Slip resistant	Material	Item number
300	A 15	No	1.4301	414141
			1.4404	414191
		Yes	1.4301	414140
			1.4404	414190
500	A 15	No	1.4301	92207
			1.4404	92257
		Yes	1.4301	92200
			1.4404	92250
1000	A 15	No	1.4301	92208
			1.4404	92258
		Yes	1.4301	92201
			1.4404	92251

ACO multi-slot 5 grating

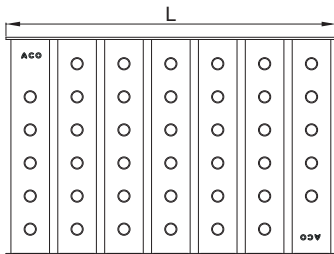

Length L [mm]	Load class	Slip resistant	Material	Item number
300	A 15	Yes	1.4301	414145
			1.4404	414195
500	A 15	Yes	1.4301	409292
			1.4404	409293
1000	A 15	Yes	1.4301	409288
			1.4404	409289

ACO multi-slot 8 grating

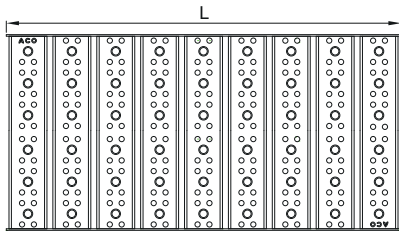

Length L [mm]	Load class	Slip resistant	Material	Item number
500	A 15	Yes	1.4301	415741
			1.4404	415742
	B 125	Yes	1.4301	415749
			1.4404	415750
1000	A 15	Yes	1.4301	415737
			1.4404	415738
	B 125	Yes	1.4301	415745
			1.4404	415746

ACO perforated grating

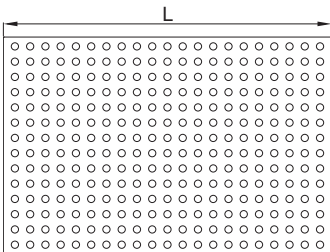

3

Length L [mm]	Load class	Slip resistant	Material	Item number
300	A 15	No	1.4301	414143
			1.4404	414193
500	A 15	No	1.4301	402689
			1.4404	405188
1000	A 15	No	1.4301	402688
			1.4404	405187

ACO hygienic slot cover

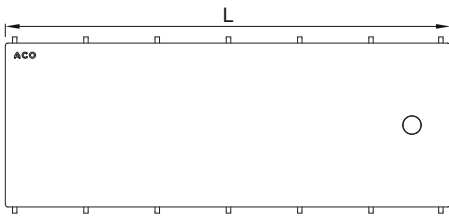

Length L [mm]	Load class	Slip resistant	Material	Item number
300	B 125	Yes	1.4301	445812
			1.4404	445813
	C 250	Yes	1.4301	445814
			1.4404	445815
500	B 125	Yes	1.4301	445804
			1.4404	445805
	C 250	Yes	1.4301	445806
			1.4404	445807
1 000	B 125	Yes	1.4301	445808
			1.4404	445809
	C 250	Yes	1.4301	445810
			1.4404	445811

Accessories for ACO modular box channel 200

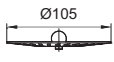
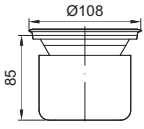
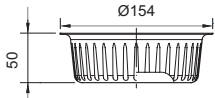
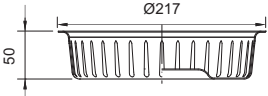
	Description	Used with	Material	Item number
	Sieve ■ Stainless steel	■ ACO modular box channel 200 with outlet 110 mm	1.4301	97235
			1.4404	97285
	Foul air trap ■ Stainless steel ■ Water seal 50 mm	■ ACO modular box channel 200 with outlet 110 mm	1.4301	97217
			1.4404	97267
	Silt basket ■ Stainless steel ■ 0.6 litre capacity	■ ACO modular box channel 200 with outlet 142 mm	1.4301	408202
			1.4404	408212
	Silt basket ■ Stainless steel ■ 1.4 litre capacity	■ ACO modular box channel 200 with outlet 200 mm	1.4301	408222
			1.4404	408232

ACO modular slot channel 20 standard articles

Product information

Ideal for wash-down applications or as a water break between designed wet and dry areas.

Modular concept allows specification of standard channel units to surround machinery and fit within existing tiling patterns.

Vee-bottomed (V) profiled channel for enhanced flow efficiency at low flow rates and for improved self cleaning performance.

Product benefits

- Fully compliant to EN 1253
- Fully tested and classified to EN 1433
- Wide range of gratings for load class up to C 250 (EN 1433)

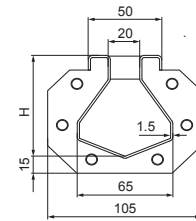

Order information

Level invert channel

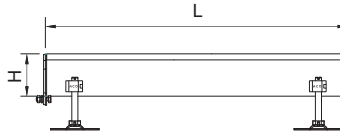

	Dimensions		Item number	
	L [mm]	H [mm]	1.4301	1.4404
500		70	92300	92350
		90	92301	92351
		120	92302	92352
1000		70	92305	92355
		90	92306	92356
		120	92307	92357
2000		70	92310	92360
		90	92311	92361
		120	92312	92362
3000		70	92316	92366
		90	92317	92367
		120	92318	92368

Note: Items are equipped with seal and connecting material on one side.

Sloping invert channel

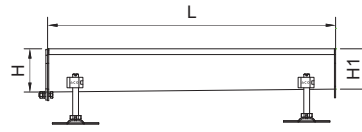

L [mm]	Dimensions		Item number	
	H1 [mm]	H2 [mm]	1.4301	1.4404
500	70	75	92303	92353
	75	80	92304	92354
1000	70	75	92308	92358
	75	80	92309	92359
2000	70	80	92313	92363
	80	90	92314	92364
	90	100	92315	92365
3000	70	80	92319	92369
	80	90	92320	92370
	90	100	92321	92371
	100	110	92322	92372
6000	110	120	92323	92373
	70	90	409014	409015
	90	110	409016	409017

Note: Items are equipped with seal and connecting material on deeper side only. See page 146 for more details.



Corner unit

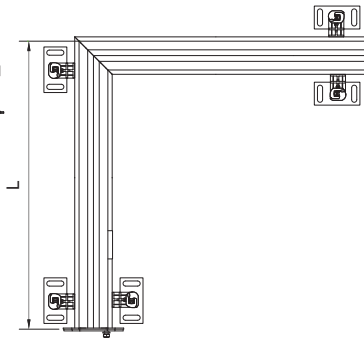
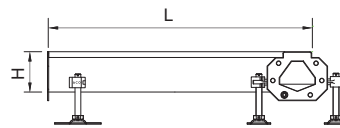

L [mm]	Dimensions		Item number	
	H [mm]	1.4301	1.4404	
500	70	92338	92388	
	75	92339	92389	
	80	92340	92390	
	90	92341	92391	
	100	92342	92392	
	110	92343	92393	
	120	92344	92394	

Note: Items are equipped with seal and connecting material on one side.

Branch unit

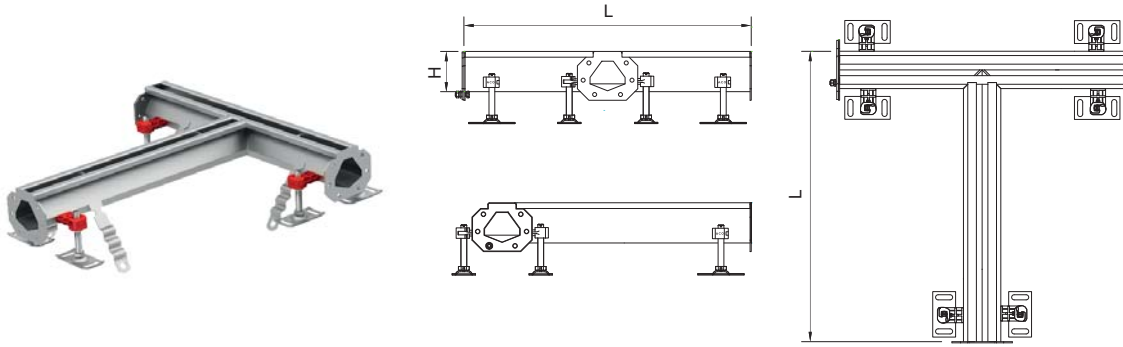

Dimensions		Item number	
L [mm]	H [mm]	1.4301	1.4404
500	70	92345	92395
	75	92346	92396
	80	92347	92397
	90	92348	92398
	100	92349	92399
	110	92400	92450
	120	92401	92451

Note: Items are equipped with seal and connecting material on one side.

End outlet

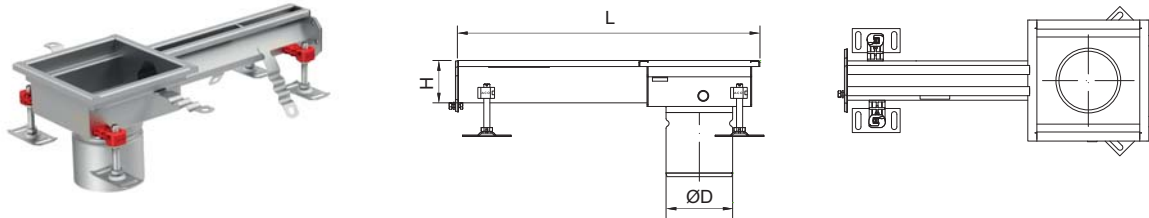

Dimensions		Gully	Gully top	Outlet diameter	Item number	
L [mm]	H [mm]		[mm]	øD [mm]	1.4301	1.4404
500	70	ACO gully EG150	200 x 200	110	414341	414348
	75				414342	414349
	80				414343	414350
	90				414344	414351
	100				414345	414352
	110				414346	414353
	120				414347	414354
	70	ACO hygienic gully 142	200 x 200	125	415925	415970
	75				415926	415971
	80				415927	415972
	90				415928	415973
	100				415929	415974
	110				415930	415975
	120				415931	415976

Note: Items are equipped with seal and connecting material on one side.

End outlet

Dimensions		Gully	Gully top	Outlet diameter	Item number	
L [mm]	H [mm]				1.4301	1.4404
500	70	ACO hygienic gully 157	250 x 250	142	414201	414208
	75				414202	414209
	80				414203	414210
	90				414204	414211
	100				414205	414212
	110				414206	414213
	120				414207	414214

Note: Items are equipped with seal and connecting material on one side.

Centre outlet

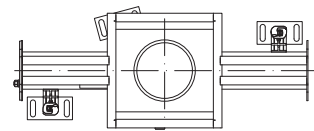
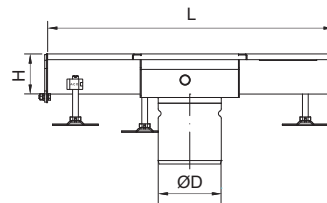

Dimensions		Gully	Gully top	Outlet diameter	Item number	
L [mm]	H [mm]				1.4301	1.4404
500	70	ACO gully EG150	200 x 200	110	414355	414362
	75				414356	414363
	80				414357	414364
	90				414358	414365
	100				414359	414366
	110				414360	414367
	120				414361	414368
1000	70	ACO hygienic gully 142	200 x 200	125	414369	414376
	75				414370	414377
	80				414371	414378
	90				414372	414379
	100				414373	414380
	110				414374	414381
500	120	ACO gully EG150	200 x 200	110	414375	414382
	70				415932	415977
	75				415933	415978
	80				415934	415979
	90				415935	415980
	100				415936	415981
	110				415937	415982
120	415938	415983				

Dimensions		Gully	Gully top [mm]	Outlet diameter øD [mm]	Item number	
L [mm]	H [mm]				1.4301	1.4404
1000	70	ACO hygienic gully 142	200 x 200	125	415939	415984
	75				415940	415985
	80				415941	415986
	90				415942	415987
	100				415943	415988
	110				415944	415989
	120				415945	415990
500	70	ACO hygienic gully 157	250 x 250	142	414215	414222
	75				414216	414223
	80				414217	414224
	90				414218	414225
	100				414219	414226
	110				414220	414227
	120				414221	414228
1000	70	ACO hygienic gully 157	250 x 250	142	414229	414236
	75				414230	414237
	80				414231	414238
	90				414232	414239
	100				414233	414240
	110				414234	414241
	120				414235	414242

Note: Items are equipped with seal and connecting material on one side.

End plate

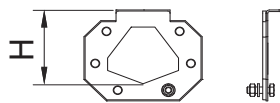

Dimensions	Item number	
	1.4301	1.4404
H [mm]		
70	92324	92374
75	92325	92375
80	92326	92376
90	92327	92377
100	92328	92378
110	92329	92379
120	92330	92380

Note: Items are equipped with seal and connecting material.

End plate with 50 mm outlet

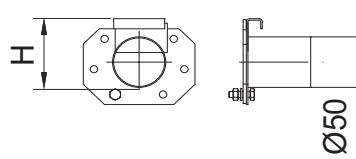

Dimensions	Item number	
	1.4301	1.4404
H [mm]		
70	92331	92381
75	92332	92382
80	92333	92383
90	92334	92384
100	92335	92385
110	92336	92386
120	92337	92387

Note: Items are equipped with seal and connecting material.

Seal rubber

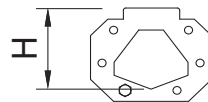

Dimensions	Item number	
	NBR	
H [mm]		
70	413601	
75	413602	
80	413603	
90	413604	
100	413605	
110	413606	
120	413607	

Note: Items are equipped with seal and connecting material.

Accessories for ACO modular slot channel 20

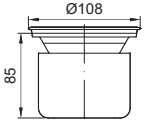
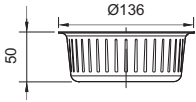
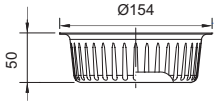
	Description	Used with	Material	Item number
	Sieve ■ Stainless steel	■ ACO modular slot channel 20 with outlet 110 mm	1.4301	97235
			1.4404	97285
	Foul air trap ■ Stainless steel ■ Water seal 50 mm	■ ACO modular slot channel 20 with outlet 110 mm	1.4301	97217
			1.4404	97267
	Silt basket ■ Stainless steel ■ 0.5 litre capacity	■ ACO modular slot channel 20 with outlet 125 mm	1.4301	414339
			1.4404	414340
	Silt basket ■ Stainless steel ■ 0.6 litre capacity	■ ACO modular slot channel 20 with outlet 142 mm	1.4301	408202
			1.4404	408212

ACO modular channel semi-standard

Product information

Semi-standard items provide an easy and fast way to get a slot or box channel of a special length to complete a linear drainage project with standard stock items. Simply specify the length you need.

How to specify semi-standard items:

Contact our customer service for assistance or use ACO Configurator to specify the dimensions of the semi-standard part which will be then produced.

How it works:

The semi-standard item is produced according to customer's need with standard flanges. The item is equipped with flange and sealing and perfectly fits the following channel in the drainage project without any step in the channel body for perfect cleanability. Grating of the same length is also produced.

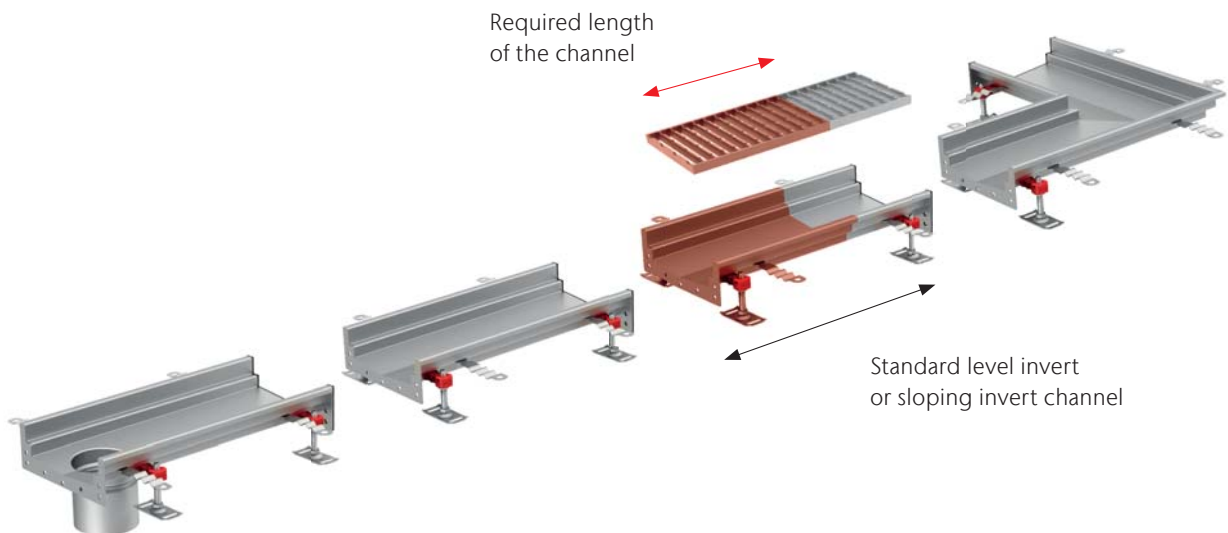

- Specify the required length of the channel and connecting heights.

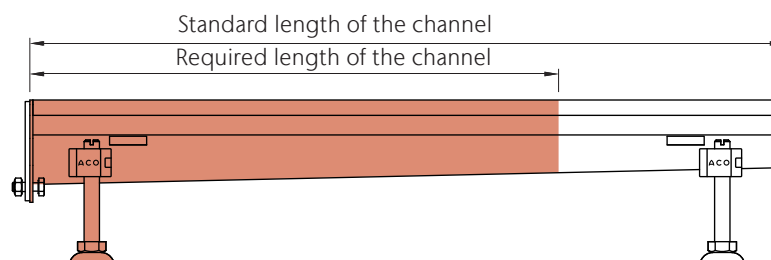

ACO design channel

Product information

Even atypical solutions can be easily realised using stainless steel. The broad spectrum of finishes and shapes gives complete design freedom.

Customers' individual channel designs will be managed by our expert team with tailor-made services for specific projects with full proposal information, CAD layout drawings and assembly instructions.

Contact our Sales/Technical department team and we will help you with your project.



Flow rates and construction heights

ACO channel – ACO hygienic gully 142, vertical

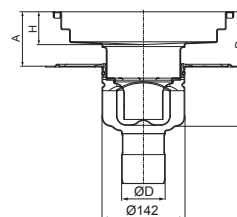

Outlet diameter	Outlet position	Flow rate [l/s]	
		H = 60 mm	
ØD		A min. = 85 B min. = 194	A max. = 115 B max. = 224
75	Vertical	1.4	1.7
110		1.6	1.9

ACO channel – ACO hygienic gully 142, horizontal

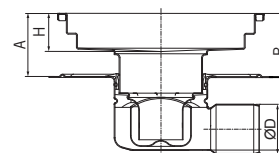

Outlet diameter	Outlet position	Flow rate [l/s]	
		H = 60 mm	
ØD		A min. = 75 B min. = 185	A max. = 115 B max. = 245
75	Horizontal	1.4	1.7
110		1.6	1.9

Notes:

A min. and B min. values can be reduced by 15 mm if earth screw is removed and channel outlet spigot shortened. Please be aware that channel outlet pipe shortening affects the A max. and B max. values.

Flow rates measured according to EN 1253. Flow rate performance without silt basket (flow rates with empty silt basket are approximately 15% lower than the values stated)

ACO channel – ACO hygienic gully 157, vertical

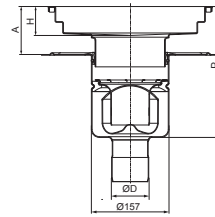

Outlet diameter	Outlet position	Flow rate [l/s]	
		H = 60 mm	
ØD	Vertical	A min. = 85	A max. = 115
		B min. = 232	B max. = 262
75	Vertical	2.9	3.1
110		3.9	4.2

ACO channel – ACO hygienic gully 157, horizontal

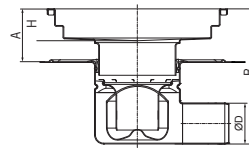

Outlet diameter	Outlet position	Flow rate [l/s]	
		H = 60 mm	
ØD	Horizontal	A min. = 75	A max. = 115
		B min. = 242	B max. = 285
75	Horizontal	2.8	3.1
110		3.2	3.9

Notes:

A min. and B min. values can be reduced by 15 mm if earth screw is removed and channel outlet spigot shortened. Please be aware that channel outlet pipe shortening affects the A max. and B max. values.

Flow rates measured according to EN 1253. Flow rate performance without silt basket (flow rates with empty silt basket are approximately 15% lower than the values stated)

ACO channel – ACO hygienic gully 218, vertical

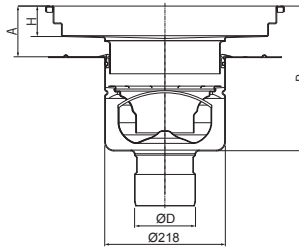

Outlet diameter	Outlet position	Flow rate [l/s]									
		H = 60 mm		H = 80 mm		H = 100 mm		H = 150 mm		H = 200 mm	
		A min.	A max.	A min.	A max.	A min.	A max.	A min.	A max.	A min.	A max.
		= 75	= 115	= 95	= 135	= 115	= 155	= 165	= 205	= 215	= 255
		[mm]	[mm]	[mm]	[mm]	[mm]	[mm]	[mm]	[mm]	[mm]	[mm]
		B min.	B max.	B min.	B max.	B min.	B max.	B min.	B max.	B min.	B max.
		= 245	= 285	= 265	= 305	= 285	= 325	= 335	= 375	= 385	= 425
		[mm]	[mm]	[mm]	[mm]	[mm]	[mm]	[mm]	[mm]	[mm]	[mm]
ØD											
110	Vertical	5.4	5.6	5.6	5.8	5.7	6.0	5.9	6.4	6.4	6.4
160	Vertical	5.4	5.6	5.6	5.8	5.7	6.0	5.9	6.4	6.4	6.4

ACO channel – ACO hygienic gully 218, horizontal

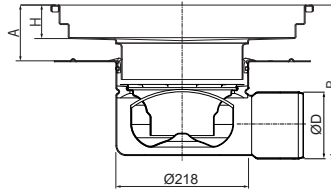

Outlet diameter	Outlet position	Flow rate [l/s]									
		H = 60 mm		H = 80 mm		H = 100 mm		H = 150 mm		H = 200 mm	
		A min.	A max.	A min.	A max.	A min.	A max.	A min.	A max.	A min.	A max.
		= 85	= 115	= 105	= 135	= 125	= 155	= 175	= 205	= 225	= 255
		[mm]	[mm]	[mm]	[mm]	[mm]	[mm]	[mm]	[mm]	[mm]	[mm]
		B min.	B max.	B min.	B max.	B min.	B max.	B min.	B max.	B min.	B max.
		= 235	= 265	= 255	= 285	= 275	= 305	= 325	= 355	= 375	= 405
		[mm]	[mm]	[mm]	[mm]	[mm]	[mm]	[mm]	[mm]	[mm]	[mm]
ØD											
110	Horizontal	4.5	4.7	4.8	4.9	4.9	5.1	5.0	5.6	5.6	6.4

Notes:

A min. and B min. values can be reduced by 15 mm if earth screw is removed and channel outlet spigot shortened. Please be aware that channel outlet pipe shortening affects the A max. and B max. values.

Flow rates measured according to EN 1253. Flow rate performance without silt basket (flow rates with empty silt basket are approximately 15% lower than the values stated)

ACO channel – ACO gully EG150, vertical

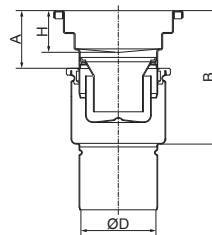

Outlet diameter	Outlet position	Flow rate [l/s]	
		H = 60 mm	
ØD	Vertical	A min. = 60	A max. = 85
		B min. = 165	B max. = 190
75	Vertical	1.3	1.5
110		1.3	1.5

ACO channel – ACO gully EG150, horizontal

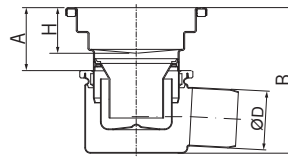

Outlet diameter	Outlet position	Flow rate [l/s]	
		H = 60 mm	
ØD	Horizontal	A min. = 60	A max. = 85
		B min. = 165	B max. = 190
75	Horizontal	1.3	1.5

Notes:

A min. and B min. values can be reduced by 15 mm if earth screw is removed and channel outlet spigot shortened. Please be aware that channel outlet pipe shortening affects the A max. and B max. values.

Flow rates measured according to EN 1253. Flow rate performance without silt basket (flow rates with empty silt basket are approximately 15% lower than the values stated)





4

ACO
Pipe

COLLECT:
Collect and remove



ACO Pipe

Introduction	Hygienic design	198
	System overview	199
Straight pipes	Straight pipes	200
	Double socketed pipes	204
	Bends	207
	Branches	210
	Single branches	211
	Double branches	212
Fittings	Single branch reductions	214
	Double branch reductions	215
	Swept single branch	216
	Accessories (Couplings, Connectors, Clamps, Seals and Cutters)	217
Flow rates	Full bore flow rate tables for varying gradients	232
Operating pressures	Operating pressures	234



Discover more in a 3D environment:
buildingdrainage.aco/products

ACO pipe
online information



Introduction

ACO pipe is the ideal system for gray and black water, rainwater and industrial waste water drainage applications.

When used with ACO gully and ACO channel systems, ACO pipe provides a unique, complex building drainage solution.

ACO pipe and fittings are available in 40 mm, 50 mm, 75 mm, 110 mm, 125 mm, 160 mm, 200 mm, 250 mm and 315 mm external diameters with the standard lengths from 0.15 meter up to 6 meter for optimum practicality and ease of assembly.

ACO pipe push-fit connection

Reliable for vacuum and gravity piping systems.

ACO pipe double lip seal delivers the ultimate system reliability. The unique and sophisticated design of lips and cavities provide tight connections.

Push-fit advantages

- Easy to assemble
- Time saving
- Cost saving
- Tight connection

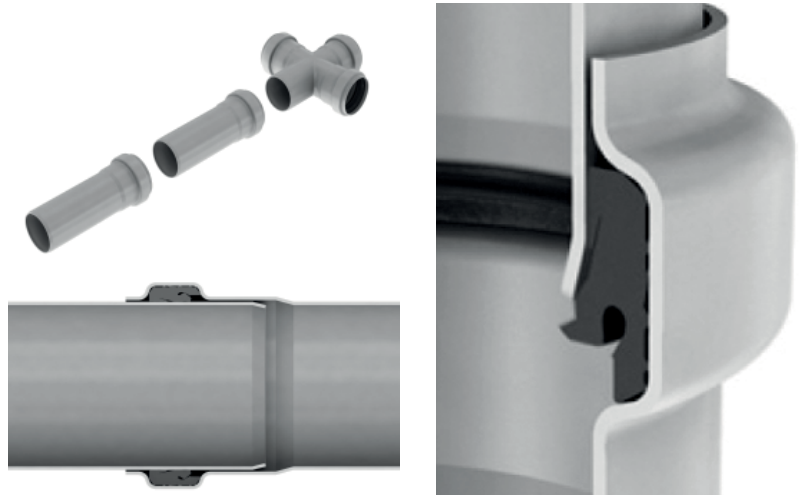

System overview

Straight pipes



Fittings



Bends



Branches



Accessories

Straight pipes

Product benefits

- Lengths from 0.15 meter up to 6 meter
- Push-fit system for quick assembly
- Superior seal security – components comprise a unique double lip sealing system, ideal for extraneous conditions
- Fully comply to EN 1124
- EPDM and Viton® seals available
- Fully pickled and passivated

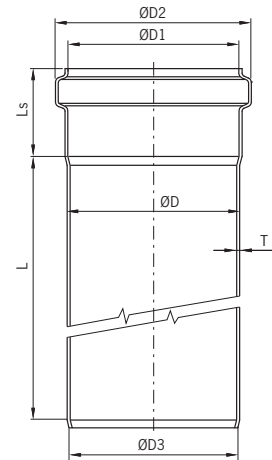

■ Dimensions of socket and spigot

øD [mm]	øD1 [mm]	øD2 [mm]	øD3 [mm]	Socket length	Wall thickness
				Ls [mm]	T [mm]
40	41	51.5	38	40	1.0
50	51	62.0	47	42	1.0
75	76	87.5	72	50	1.0
110	111	125.5	107	57	1.0
125	126	141.0	122	63	1.0
160	161	178.0	156	70	1.25
200	201	219.0	195	80	1.5
250	251	268.6	245	90	1.5
315	316.2	334.2	309	100	2.0

Order information

ACO pipe - straight pipe 40 mm

Seal material	Outlet diameter	Active length	Weight	Item number	Item number
	øD [mm]	L [mm]	[kg]	1.4301	1.4404
EPDM	40	150	0.2	417304	417320
	40	250	0.3	417306	417322
	40	500	0.6	417308	417324
	40	750	0.8	417310	417326
	40	1000	1.1	417312	417328
	40	1500	1.6	417314	417330
	40	2000	2.1	417316	417332
	40	2500	2.8	417260	417262
	40	3000	3.1	417318	417334
	40	4000	4.1	417264	417270
	40	5000	5.1	417266	417272
	40	6000	6.1	417268	417274

ACO pipe - straight pipe 50 mm

Seal material	Outlet diameter	Active length	Weight	Item number	Item number
	øD [mm]	L [mm]	[kg]	1.4301	1.4404
EPDM	50	150	0.2	98500	98550
	50	250	0.4	98502	98552
	50	500	0.7	98504	98554
	50	750	1.0	98506	98556
	50	1000	1.3	98508	98558
	50	1500	1.9	98510	98560
	50	2000	2.6	98512	98562
	50	2500	3.2	419274	419282
	50	3000	3.8	98514	98564
	50	4000	5.0	419458	419482
	50	5000	6.3	419466	419490
	50	6000	7.5	419474	419498

ACO pipe - straight pipe 75 mm

Seal material	Outlet diameter	Active length	Weight	Item number	Item number
	øD [mm]	L [mm]	[kg]	1.4301	1.4404
EPDM	75	150	0.4	98516	98566
	75	250	0.6	98518	98568
	75	500	1.0	98520	98570
	75	750	1.5	98522	98572
	75	1000	2.0	98524	98574
	75	1500	2.9	98526	98576
	75	2000	3.6	98528	98578
	75	2500	4.8	419276	419284
	75	3000	5.7	98530	98580
	75	4000	7.6	419460	419484
	75	5000	9.4	419468	419492
	75	6000	11.3	419476	419500

ACO pipe - straight pipe 110 mm

Seal material	Outlet diameter	Active length	Weight	Item number	Item number
	øD [mm]	L [mm]	[kg]	1.4301	1.4404
EPDM	110	150	0.6	98532	98582
	110	250	0.9	98534	98584
	110	500	1.5	98536	98586
	110	750	2.2	98538	98588
	110	1000	2.9	98540	98590
	110	1500	4.3	98542	98592
	110	2000	5.7	98544	98594
	110	2500	7.1	419278	419286
	110	3000	8.4	98546	98596
	110	4000	11.1	419462	419486
	110	5000	13.9	419470	419494
	110	6000	16.7	419478	419502

ACO pipe - straight pipe 125 mm

Seal material	Outlet diameter	Active length	Weight	Item number	Item number
	øD [mm]	L [mm]	[kg]	1.4301	1.4404
EPDM	125	150	0.7	419692	419712
	125	250	1.0	419694	419714
	125	500	1.7	419696	419716
	125	750	2.5	419698	419718
	125	1000	3.3	419700	419720
	125	1500	4.9	419702	419722
	125	2000	6.5	419704	419724
	125	2500	8.1	419708	419728
	125	3000	9.6	419706	419726
	125	6000	19.0	419710	419730

ACO pipe - straight pipe 160 mm

Seal material	Outlet diameter	Active length	Weight	Item number	Item number
	øD [mm]	L [mm]	[kg]	1.4301	1.4404
EPDM	160	150	1.1	98548	98598
	160	250	1.6	98600	98650
	160	500	2.9	98602	98652
	160	750	4.1	98604	98654
	160	1000	5.4	98606	98656
	160	1500	7.9	98608	98658
	160	2000	10.4	98610	98660
	160	2500	12.9	419280	419288
	160	3000	15.4	98612	98662
	160	4000	20.4	419464	419488
	160	5000	25.4	419472	419496
	160	6000	30.4	419480	419504

ACO pipe - straight pipe 200 mm

Seal material	Outlet diameter	Active length	Weight	Item number	Item number
	øD [mm]	L [mm]	[kg]	1.4301	1.4404
EPDM	200	500	4.5	419383	419384
	200	1000	8.3	419387	419388
	200	2000	15.8	419391	419392
	200	3000	23.2	419395	419396

ACO pipe - straight pipe 250 mm

Seal material	Outlet diameter	Active length	Weight	Item number	Item number
	øD [mm]	L [mm]	[kg]	1.4301	1.4404
EPDM	250	500	5.5	417071	417072
	250	1000	10.2	417075	417076
	250	2000	19.4	417079	417080
	250	3000	28.7	417083	417084

ACO pipe - straight pipe 315 mm

Seal material	Outlet diameter	Active length	Weight	Item number	Item number
	øD [mm]	L [mm]	[kg]	1.4301	1.4404
EPDM	315	500	9.8	417238	417200
	315	1000	17.7	417239	417201
	315	2000	33.5	417240	417202
	315	3000	49.3	417241	417203

Double socketed pipes

Product benefits

- Lengths from 0.15 meter up to 6 meter
- Push-fit system for quick assembly
- Superior seal security – components comprise a unique double lip sealing system, ideal for extraneous conditions
- Fully comply to EN 1124
- EPDM and Viton® seals available
- Fully pickled and passivated

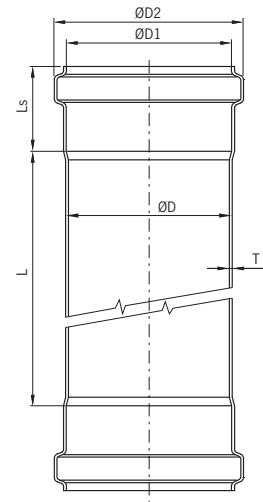

■ Dimensions of socket and spigot

øD [mm]	øD1 [mm]	øD2 [mm]	øD3 [mm]	Socket length	Wall thickness
				Ls [mm]	T [mm]
40	41	51.5	38	40	1.0
50	51	62.0	47	42	1.0
75	76	87.5	72	50	1.0
110	111	125.5	107	57	1.0
125	126	141.0	122	63	1.0
160	161	178.0	156	70	1.25
200	201	219.0	195	80	1.5
250	251	268.6	245	90	1.5
315	316.2	334.2	309	100	2.0

Order information

ACO pipe - double socketed pipe 40 mm

Seal material	Outlet diameter	Active length	Weight	Item number	Item number
	øD [mm]	L [mm]	[kg]	1.4301	1.4404
EPDM	40	250	0.2	417276	417290
	40	500	0.6	417278	417292
	40	750	0.9	417280	417294
	40	1000	1.2	417282	417296
	40	1500	1.8	417284	417298
	40	2000	2.4	417286	417300
	40	3000	3.6	417288	417302

ACO pipe - double socketed pipe 50 mm

Seal material	Outlet diameter	Active length	Weight	Item number	Item number
	øD [mm]	L [mm]	[kg]	1.4301	1.4404
EPDM	50	250	0.4	419554	419594
	50	500	0.7	419556	419596
	50	750	1.1	419558	419598
	50	1000	1.4	419560	419600
	50	1500	2.0	419562	419602
	50	2000	2.6	419564	419604
	50	3000	3.9	419566	419606

ACO pipe - double socketed pipe 75 mm

Seal material	Outlet diameter	Active length	Weight	Item number	Item number
	øD [mm]	L [mm]	[kg]	1.4301	1.4404
EPDM	75	250	0.7	419568	419608
	75	500	1.2	419570	419610
	75	750	1.6	419572	419612
	75	1000	2.1	419574	419614
	75	1500	3.0	419576	419616
	75	2000	4.0	419578	419618
	75	3000	5.8	419580	419620

ACO pipe - double socketed pipe 110 mm

Seal material	Outlet diameter	Active length	Weight	Item number	Item number
	øD [mm]	L [mm]	[kg]	1.4301	1.4404
EPDM	110	500	1.7	419582	419622
	110	750	2.4	419584	419624
	110	1000	3.0	419586	419626
	110	1500	4.4	419588	419628
	110	2000	5.7	419590	419630
	110	3000	8.4	419592	419632

ACO pipe - double socketed pipe 125 mm

Seal material	Outlet diameter	Active length	Weight	Item number	Item number
	øD [mm]	L [mm]	[kg]	1.4301	1.4404
EPDM	125	500	1.7	419787	419799
	125	750	2.5	419789	419801
	125	1000	3.3	419791	419803
	125	1500	4.9	419793	419805
	125	2000	6.5	419795	419807
	125	3000	9.6	419797	419809

ACO pipe - double socketed pipe 160 mm

Seal material	Outlet diameter	Active length	Weight	Item number	Item number
	øD [mm]	L [mm]	[kg]	1.4301	1.4404
EPDM	160	500	3.3	419634	419646
	160	750	4.5	419636	419648
	160	1000	5.8	419638	419650
	160	1500	8.2	419640	419652
	160	2000	10.7	419642	419654
	160	3000	15.7	419644	419656

ACO pipe - double socketed pipe 200 mm

Seal material	Outlet diameter	Active length	Weight	Item number	Item number
	øD [mm]	L [mm]	[kg]	1.4301	1.4404
EPDM	200	500	5.0	419658	419659
	200	1000	8.6	419662	419663
	200	2000	15.9	419666	419667
	200	3000	23.1	419670	419671

Bends

Product benefits

- Push-fit system for quick assembly
- Superior seal security – components comprise a unique double lip sealing system, ideal for extraneous conditions
- Fully chemically pickled and passivated
- EPDM and Viton® seals available
- Fully comply to EN 1124

ACO pipe - bend 87.5°

Shape valid for øD 40, 50, 75, 110 and 160

Shape valid for øD 125, 200, 250 and 315

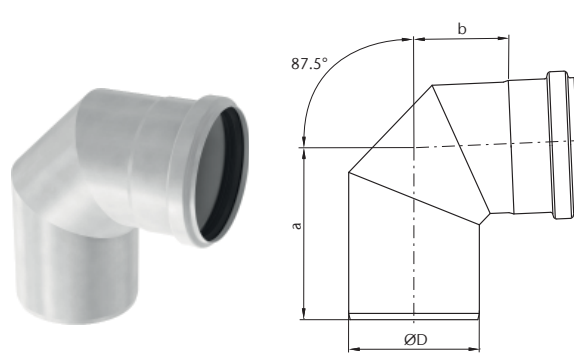
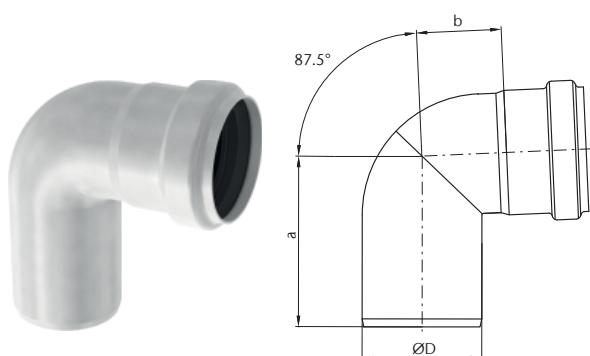

Seal material	Outlet diameter	Dimensions		Weight kg	Item number	
	øD [mm]	a [mm]	b [mm]		1.4301	1.4404
EPDM	40	79	32	0.2	417342	417350
	50	86	40	0.2	98700	98750
	75	107	53	0.4	98702	98752
	110	134	67	0.7	98704	98754
	125	161	93	0.8	419732	419734
	160	181	105	1.7	98706	98756
	200	215	129	3.9	419411	419413
	250	297	198	5.1	-	417088
	315	393	286	12.8	-	417204

ACO pipe - bend 45°

Shape valid for $\varnothing D$ 40, 50, 75, 110 and 160

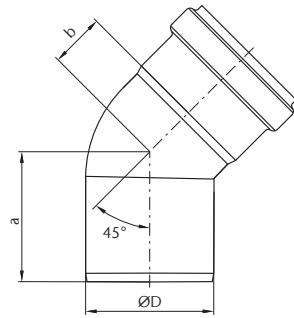

Shape valid for $\varnothing D$ 125, 200, 250 and 315

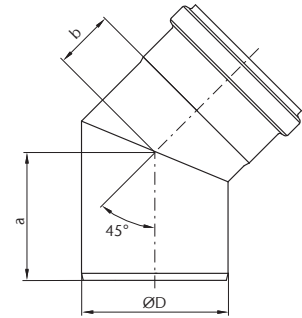

Seal material	Outlet diameter $\varnothing D$ [mm]	Dimensions		Weight kg	Item number	Item number
		a [mm]	b [mm]		1.4301	1.4404
EPDM	40	58	21	0.2	417344	417352
	50	62	24	0.2	98708	98758
	75	76	32	0.3	98710	98760
	110	93	42	0.5	98712	98762
	125	110	50	0.6	419736	419738
	160	131	55	1.3	98714	98764
	200	152	60	2.7	419407	419409
	250	177	76	4.1	-	417092
	315	199	91	7.2	-	417205

ACO pipe - bend 30°

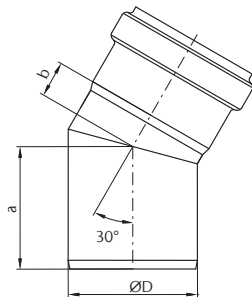

Seal material	Outlet diameter $\varnothing D$ [mm]	Dimensions		Weight kg	Item number	Item number
		a [mm]	b [mm]		1.4301	1.4404
EPDM	40	55	14	0.1	417346	417354
	50	57	16	0.2	98716	98766
	75	71	21	0.3	98718	98768
	110	85	27	0.5	98720	98770
	125	98	28	0.6	419740	419742
	160	110	40	1.2	98722	98772
	200	137	45	2.3	419403	419405
	250	153	58	2.9	-	417096
	315	172	68	5.8	-	417206

ACO pipe - bend 15°

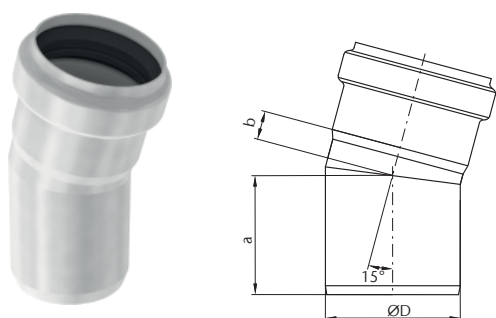

Seal material	Outlet diameter ØD [mm]	Dimensions		Weight kg	Item number 1.4301	Item number 1.4404
		a [mm]	b [mm]			
EPDM	40	53	11	0.1	417348	417356
	50	54	12	0.1	98724	98774
	75	66	16	0.3	98726	98776
	110	78	15	0.4	98728	98778
	125	84	19	0.5	419744	419746
	160	99	29	1.0	98730	98780
	200	123	31	1.9	419399	419401
	250	136	40	2.5	-	417100
315	151	46	5.4	-	417207	

ACO pipe - long bend 87.5°

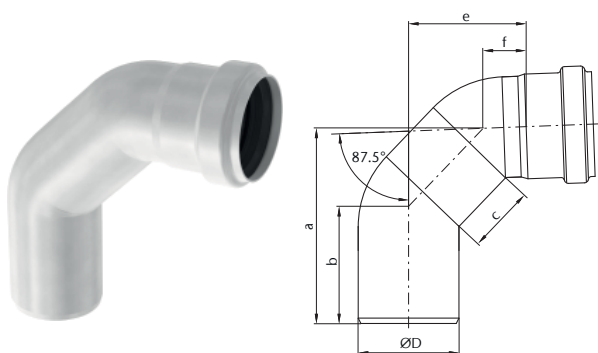

Seal material	Outlet diameter ØD [mm]	Dimensions					Weight [kg]	Item number 1.4301	Item number 1.4404
		a [mm]	b [mm]	c [mm]	e [mm]	f [mm]			
EPDM	40	105	64	50	67	40	0.2	417340	417338
	50	123	71	50	75	25	0.3	419146	419000
	75	146	87	50	88	32	0.5	419148	419002
	110	316	103	250	246	39	1.4	419150	419004
	160	360	126	250	270	92	2.2	419152	419144

Branches

Product benefits

- Push-fit system for quick assembly
- Superior seal security – components comprise a unique double lip sealing system, ideal for extraneous conditions
- Fully comply to EN 1124
- EPDM and Viton® seals available
- Fully pickled and passivated

ACO pipe - single branch

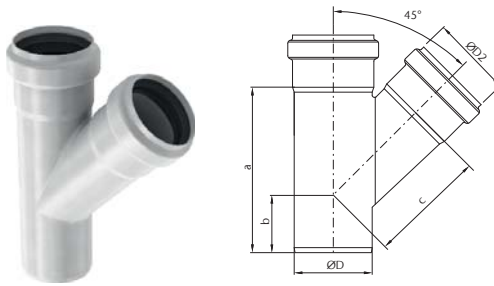

ACO pipe - double branch

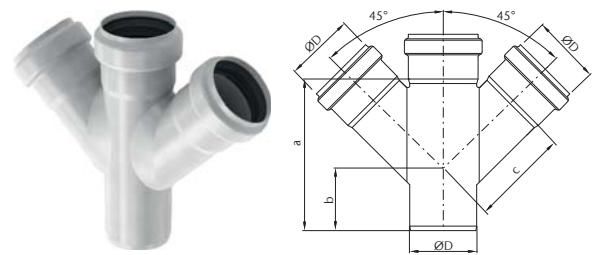

ACO pipe - single branch reduction

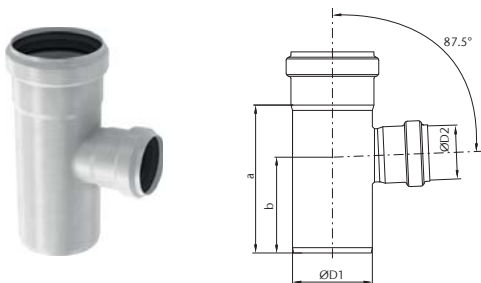

ACO pipe - double branch reduction

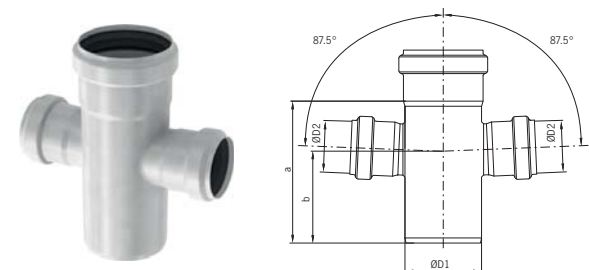

ACO pipe - swept single branch

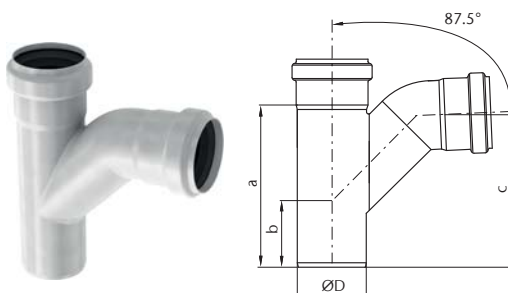

Single branches

ACO pipe - single branch 87.5°

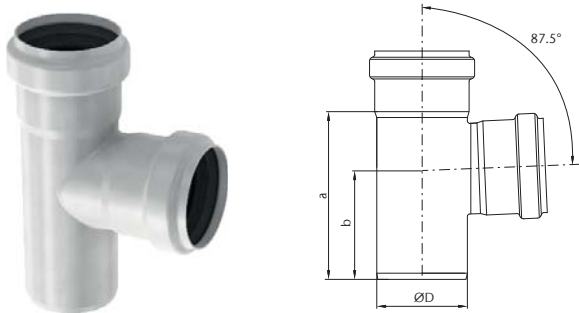

Seal material	Outlet diameter	Dimensions		Weight	Item number	Item number
	ØD [mm]	a [mm]	b [mm]			
EPDM	40	101	69	0.3	417362	417368
	50	106	71	0.3	98732	98782
	75	139	90	0.5	98734	98784
	110	183	117	0.8	98736	98786
	125	220	135	0.9	419748	419750
	160	288	184	2.3	98738	98788
	200	333	206	4.5	419419	419421
	250	363	215	5.5	-	417104
	315	476	281	14.8	-	417208

ACO pipe - single branch 45°

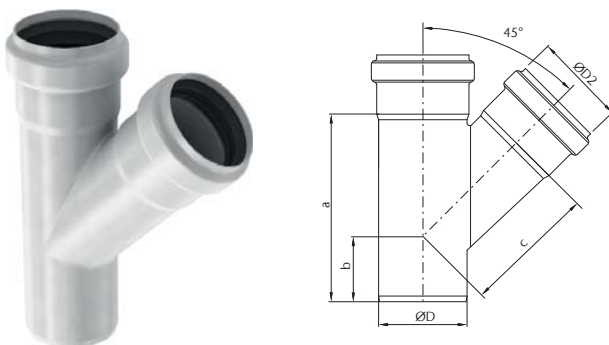

Seal material	Outlet diameter	Dimensions			Weight	Item number	Item number
	ØD [mm]	a [mm]	b [mm]	c [mm]			
EPDM	40	118	58	63	0.3	417366	417372
	50	128	57	76	0.3	98748	98798
	75	179	74	110	0.5	98800	98850
	110	233	88	149	1.0	98802	98852
	125	273	103	170	1.1	419760	419762
	160	332	119	222	2.6	98804	98854
	200	415	151	274	5.7	419427	419429
	250	513	172	336	9.2	-	417108
	315	616	195	521	20.6	-	417209

Double branches

ACO pipe - double branch 87.5°

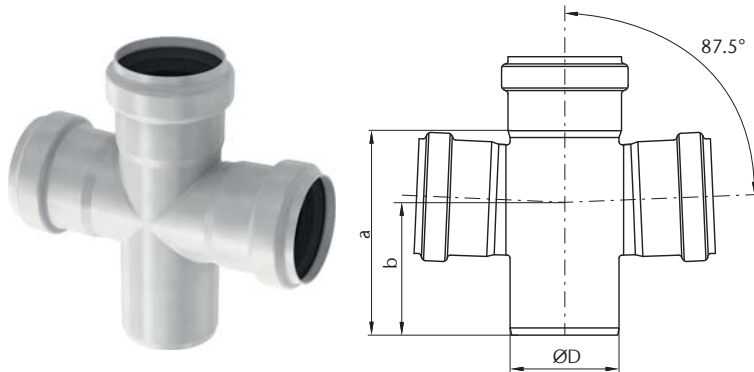

Seal material	Outlet diameter ØD [mm]	Dimensions		Weight kg	Item number 1.4301	Item number 1.4404
		a [mm]	b [mm]			
EPDM	40	101	69	0.3	417364	417370
	50	106	71	0.3	98740	98790
	75	139	90	0.6	98742	98792
	110	183	117	0.9	98744	98794
	160	288	184	2.7	98746	98796

ACO pipe - double branch 45°

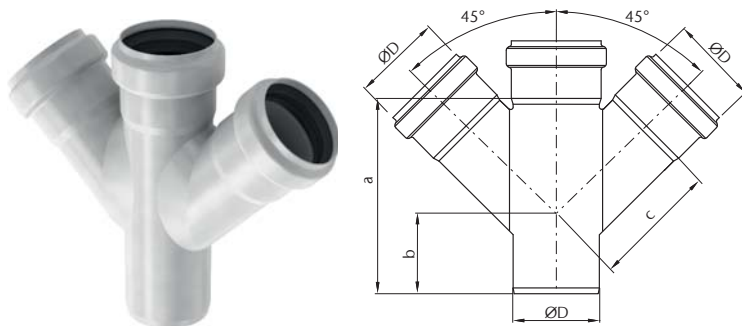

Seal material	Outlet diameter ØD [mm]	Dimensions			Weight [kg]	Item number 1.4301	Item number 1.4404
		a [mm]	b [mm]	c [mm]			
EPDM	40	118	58	63	0.4	417374	417378
	50	128	57	76	0.4	98806	98856
	75	179	74	110	0.7	98808	98858
	110	233	88	149	1.2	98810	98860
	160	332	184	222	3.5	98812	98862
	250	509	172	336	11	-	417120
	315	616	195	521	29.7	-	417212

ACO pipe - double branch 87.5°

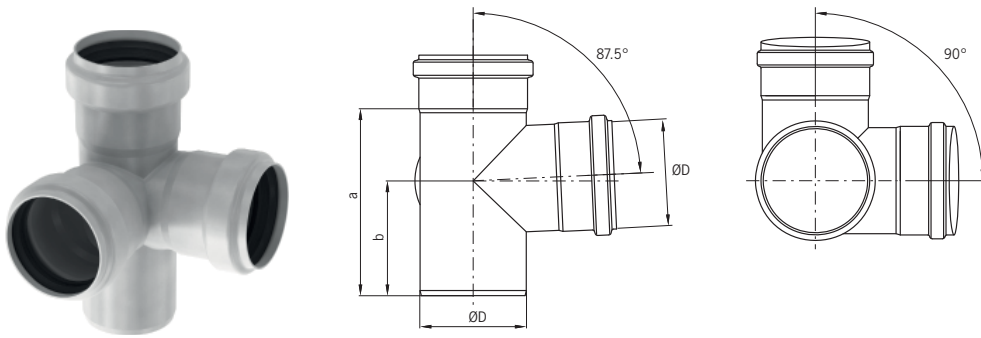

Seal material	Outlet diameter øD [mm]	Dimensions		Weight kg	Item number	Item number
		a [mm]	b [mm]		1.4301	1.4404
EPDM	40	101	69	0.3	417414	417415
	50	106	71	0.4	419162	419210
	75	139	90	0.7	419164	419212
	110	183	117	1.1	419166	419214
	160	288	184	2.9	419168	419216

Single branch reductions

ACO pipe - single branch reduction 87.5°

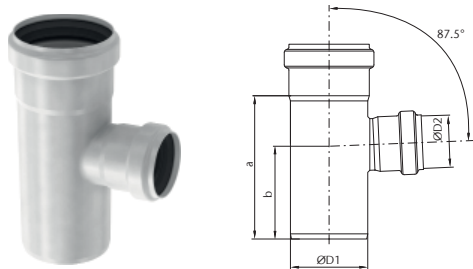

Seal material	Outlet diameter		Dimensions		Weight [kg]	Item number 1.4301	Item number 1.4404
	ØD1 [mm]	ØD2 [mm]	a [mm]	b [mm]			
EPDM	50	40	106	98	0.3	417442	417443
	75	40	139	98	0.3	417444	417445
	75	50	139	90	0.3	98928	98930
	110	50	183	117	0.5	98932	98934
	110	75	183	117	0.8	98936	98938
	125	75	187	110	0.9	419752	419754
	125	110	205	127	0.9	419756	419758
	160	110	288	184	2.3	400691	400693
	200	160	293	186	3.7	419415	419417
	250	200	349	226	5.8	-	417112
	315	250	411	248	10.5	-	417210

ACO pipe - single branch reduction 45°

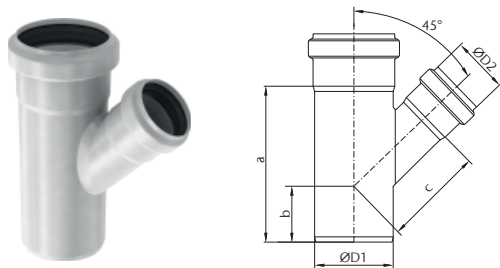

Seal material	Outlet diameter		Dimensions			Weight [kg]	Item number 1.4301	Item number 1.4404
	ØD1 [mm]	ØD2 [mm]	a [mm]	b [mm]	c [mm]			
EPDM	50	40	119	55	71	0.3	417406	417408
	75	40	144	94	56	0.3	417446	417447
	75	50	144	56	94	0.3	400661	400663
	110	50	147	42	119	0.5	400665	400667
	110	75	182	60	135	1.0	400669	400671
	125	75	200	65	141	1.1	419764	419766
	125	110	250	90	160	1.1	419768	419770
	160	110	332	119	191	2.6	400699	400701
	200	160	359	123	250	4.7	419423	419425
	250	200	429	175	307	7.6	-	417116
	315	250	513	149	382	14.0	-	417211

Double branch reductions

ACO pipe - double branch reduction 87.5°

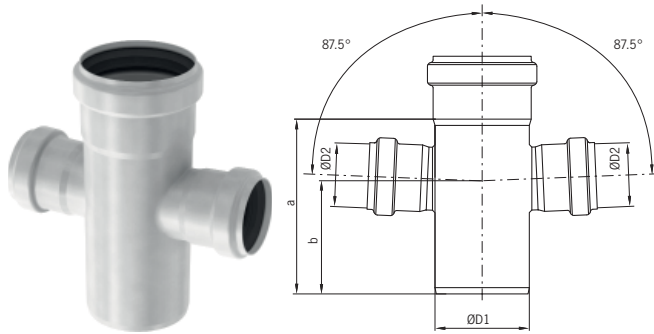

Seal material	Outlet diameter		Dimensions		Weight [kg]	Item number 1.4301	Item number 1.4404
	ØD1 [mm]	ØD2 [mm]	a [mm]	b [mm]			
EPDM	50	40	106	71	0.25	417398	417399
	75	50	139	90	0.3	98940	98942
	110	50	183	117	0.6	98944	98946
	110	75	183	117	0.9	98900	98902
	160	110	288	184	2.7	400695	400697

ACO pipe - double branch reduction 45°

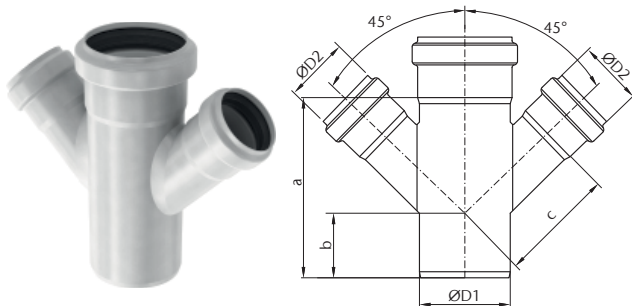

Seal material	Outlet diameter		Dimensions			Weight [kg]	Item number 1.4301	Item number 1.4404
	ØD1 [mm]	ØD2 [mm]	a [mm]	b [mm]	c [mm]			
EPDM	50	40	119	55	71	0.3	417410	417412
	75	50	144	56	94	0.4	400673	400675
	110	50	147	42	119	0.7	400677	400679
	110	75	182	60	135	1.2	400681	400683
	160	110	332	119	190	3.5	400703	400705
	250	200	429	150	307	10.1	-	417124
	315	250	513	149	382	17.8	-	417213

Swept single branch

ACO pipe - swept single branch 87.5°

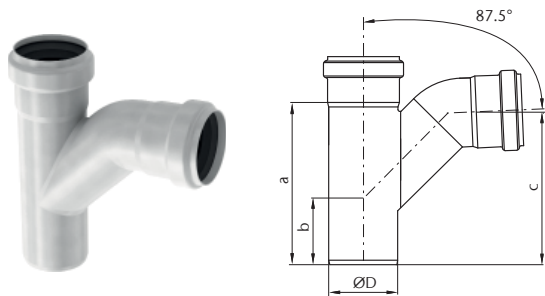

Seal material	Outlet diameter	Dimensions			Weight	Item number	Item number
		øD [mm]	a [mm]	b [mm]			
EPDM	40	115	55	105	0.3	417376	417380
	50	128	57	117	0.3	98814	98864
	75	179	74	157	0.6	98816	98866
	110	233	88	209	1.1	98818	98868
	160	332	184	302	2.8	98820	98870

Accessories

Product benefits

- Push-fit system for quick assembly
- Superior seal security – components comprise a unique double lip sealing system, ideal for extraneous conditions
- Fully comply to EN 1124
- EPDM and Viton® seals available
- Fully pickled and passivated

“P” trap

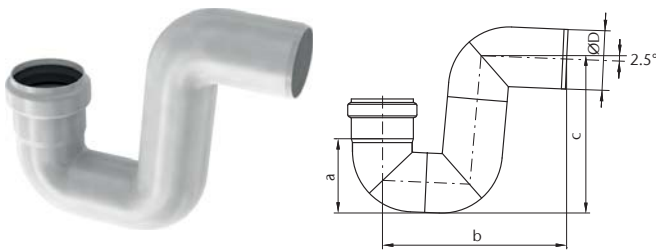

Seal material	Outlet diameter	Dimensions			Weight	Item number	Item number
	ØD [mm]	a [mm]	b [mm]	c [mm]	[kg]	1.4301	1.4404
EPDM	50	68	187	149	0.5	98822	98872
	75	94	232	193	0.7	98824	98874
	110	132	300	254	1.3	98826	98876
	160	190	403	347	3.3	98828	98878

Straight coupling

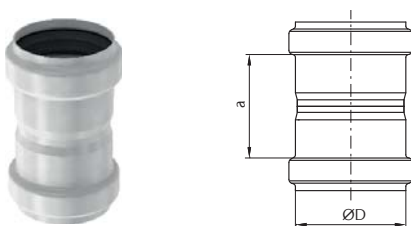

Seal material	Outlet diameter	Dimensions	Weight	Item number	Item number
	ØD [mm]	a [mm]	[kg]	1.4301	1.4404
EPDM	40	51	0.1	417392	417394
	50	54	0.1	98920	98970
	75	75	0.2	98922	98972
	110	84	0.4	98924	98974
	125	140	0.4	419813	419815
	160	110	0.8	98926	98976
	200	136	1.8	419431	419433
	250	181	3.1	-	417160
	315	179	5.2	-	417225

Repair coupling

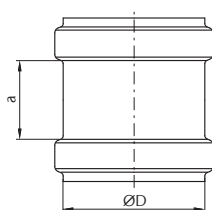

Seal material	Outlet diameter	Dimensions		Weight	Item number	Item number
	ØD [mm]	a [mm]		[kg]	1.4301	1.4404
EPDM	40	57		0.1	417388	417390
	50	44		0.1	98830	98880
	75	46		0.2	98832	98882
	110	52		0.3	98834	98884
	125	70		0.3	419772	419774
	160	76		0.7	98836	98886
	200	100		1.5	419435	419437
	250	182		2.4	-	417139
	315	179		4.9	-	417220

Note:

Repair couplings are used to aid a convenient repair to a damaged in-situ pipe. Unlike the standard straight coupling, there is no central registration to limit the insertion depth of the pipe. The repair coupling slides completely over a pipe joint and simply re-positioned to bridge the required pipe joint.

Installation tip:

Mark the final position of the repair coupling on the installed pipe system to ensure the coupling seals are positioned symmetrically about the pipe joint.

Expansion socket

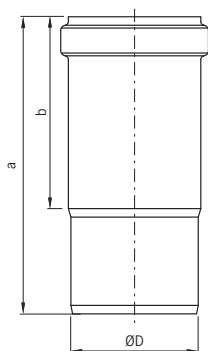

Seal material	Outlet diameter	Dimensions		Weight	Item number	Item number
	ØD1 [mm]	a [mm]	b [mm]	[kg]	1.4301	1.4404
EPDM	40	150	90	0.2	417382	417384
	50	159	102	0.2	98664	98666
	75	175	113	0.3	98668	98670
	110	200	121	0.5	98672	98674
	125	250	165	0.6	419776	419778
	160	292	170	1.4	98676	98678
	250	400	190	3.8	-	417143
	315	450	200	7.2	-	417221
	200	180	350	2.4	417194	417196

Eccentric increaser coupling

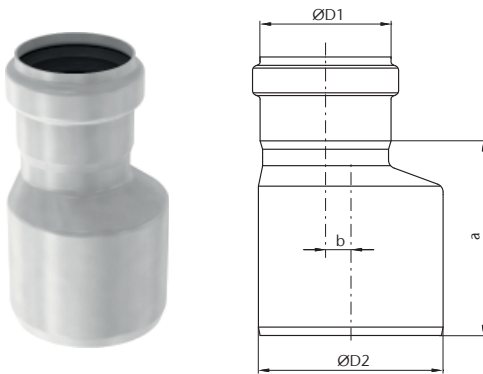

Seal material	Outlet diameter		Dimensions		Weight [kg]	Item number
	ØD1 [mm]	ØD2 [mm]	a [mm]	b [mm]		
EPDM	40	50	85	5	0.3	1.4404
	40	75	85	17	0.3	417418
	50	75	75	7	0.3	417419
	50	110	110	25	0.4	98892
	75	110	110	15	0.5	98978
	110	160	160	22	1.1	98894
	200	250	180	15	2.4	98896
	250	315	190	15	4.4	417135

Concentric increaser coupling

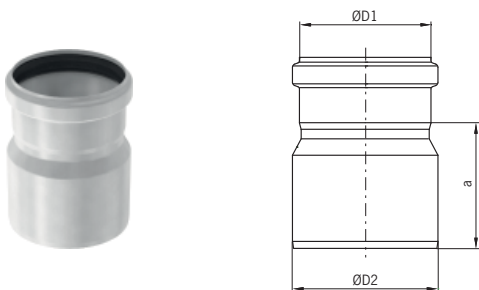

Seal material	Outlet diameter		Dimensions a [mm]	Weight [kg]	Item number
	ØD1 [mm]	ØD2 [mm]			
EPDM	40	50			1.4404
	40	75	85	0.3	417403
	50	75	88	0.3	417417
	50	110	113	1.4	419826
	75	110	105	0.6	417018
	110	125	107	0.6	419828
	110	160	126	0.9	419780
	125	160	160	1.2	419830
	160	200	200	1.8	419811
	200	250	180	2.4	419441
	315	250	190	4.4	417133

Increaser connector

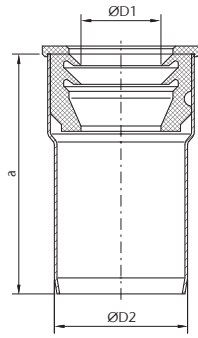

Seal material	Outlet diameter		Dimensions	Weight	Item number
	$\varnothing D1$ [mm]	$\varnothing D2$ [mm]			
NBR	32	50	90	0.2	419373
	40	50	90	0.2	419374

Connector with internal screw thread and spigot

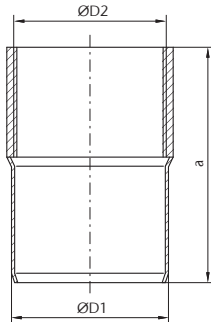

Outlet diameter		Dimensions	Weight	Item number
$\varnothing D1$ [mm]	$\varnothing D2$ [mm]			
40	G 1¼"	70	0.2	417337
50	G 1¼"	72	0.2	98956
50	G 1½"	75	0.3	98957
50	G 2"	80	0.3	98958

Connector with external screw thread and spigot

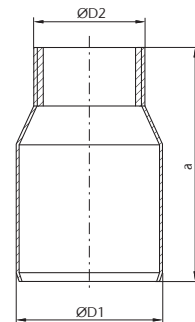

Outlet diameter		Dimensions	Weight	Item number
$\varnothing D1$ [mm]	$\varnothing D2$ [mm]			
50	G 1¼"	100	0.2	419330
50	G 1½"	100	0.3	419331
50	G 2"	100	0.3	419332

Connector with socket and internal screw thread

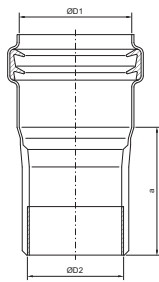

Seal material	Outlet diameter		Dimensions	Weight	Item number
	$\varnothing D1$ [mm]	$\varnothing D2$ [mm]	a [mm]	[kg]	1.4404
EPDM	40	G 1¼"	35	0.2	417336
	50	G 1¼"	58	0.2	419333
	50	G 1½"	58	0.3	419335
	50	G 2"	58	0.3	419337

Connector with socket and external screw thread

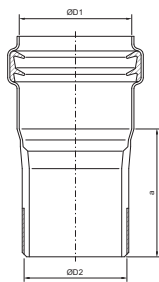

Seal material	Outlet diameter		Dimensions	Weight	Item number
	$\varnothing D1$ [mm]	$\varnothing D2$ [mm]	a [mm]	[kg]	1.4404
EPDM	50	G 1¼"	58	0.2	419250
	50	G 1½"	58	0.3	419252
	50	G 2"	58	0.3	419254

Connector cast iron spigot → ACO pipe socket

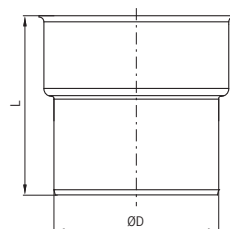

Outlet diameter	Dimensions	Weight	Item number
$\varnothing D$ [mm]	L [mm]	[kg]	1.4404
75	121	0.4	98904
110	137	0.6	98906
160	174	1.0	98905

Note: To be used with reduction sealing item number 400580 for DN 75 and 400581 for DN 110

Connector with socket and flange

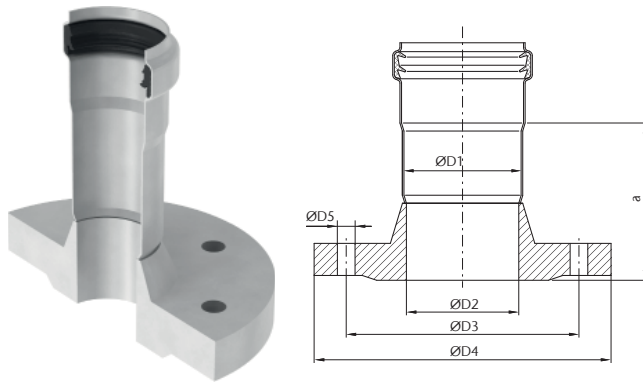

Seal material	Outlet diameter				n x ØD5 [mm]	Dimensions a [mm]	Weight [kg]	Item number
	ØD1 [mm]	ØD2 [mm]	ØD3 [mm]	ØD4 [mm]				
EPDM	40	DN 40	110	150	4 x 18	100	2.0	417420
	40	DN 40	110	150	4 x 18	100	2.0	417421
	50	DN 40	110	150	4 x 18	100	2.3	419256
	50	DN 50	125	165	4 x 18	100	2.7	419258
	75	DN 65	145	185	4 x 18	100	3.4	419260
	110	DN 100	180	220	8 x 18	100	4.9	419262
	200	DN 200	295	340	12 x 22	102	12.0	419514

Note: n – number of holes for screws in the flange. Flange PN 16 DIN 2633. | Flange PN 6 and PN 10 available on request.

Connector with flange and spigot

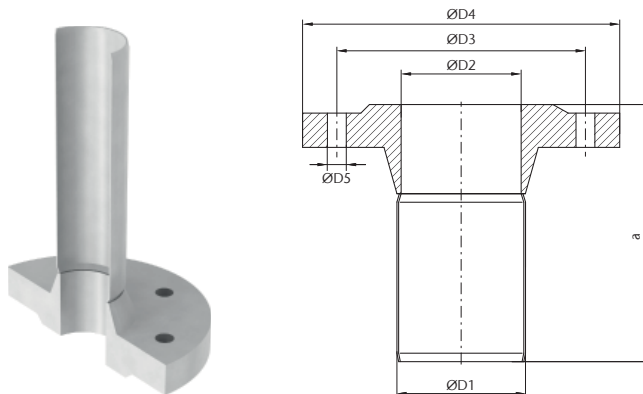

ØD1 [mm]	Outlet diameter			n x ØD5 [mm]	Dimensions a [mm]	Weight [kg]	Item number
	ØD2 [mm]	ØD3 [mm]	ØD4 [mm]				
40	DN 40	100	130	4 x 18	161	1.6	417430
40	DN 50	100	130	4 x 18	161	1.6	417431
40	DN 40	110	150	4 x 18	165	2.0	417422
40	DN 50	110	150	4 x 18	165	2.0	417423
50	DN 40	110	150	4 x 18	192	2.3	419264
50	DN 50	125	165	4 x 18	192	2.7	419265
75	DN 65	145	185	4 x 18	245	3.4	419266
110	DN 100	180	220	8 x 18	259	4.9	419267
160	DN 150	240	285	8 x 22	200	8.5	419540
200	DN 200	295	240	12 x 22	240	12.3	419541

Note: n – number of holes for screws in the flange. Flange PN 16 DIN 2633. | Flange PN 6 and PN 10 available on request.

Access unit

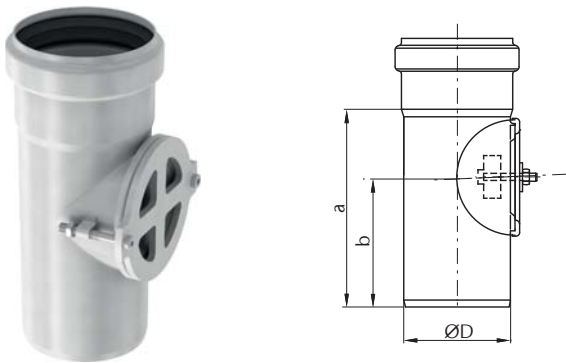

Seal material	Outlet diameter		Dimensions		Weight kg	Item number	
	ØD [mm]		a [mm]	b [mm]		1.4301	1.4404
EPDM	75		139	90	0.5	98913	98963
	110		183	117	0.8	98915	98965
	125		210	135	0.9	419783	419785
	160		288	184	2.3	98917	98967
	200		293	186	3.7	419676	419678
	250		290	184	3.8	-	417128
	315		340	228	8.9	-	417214

Rat-stop

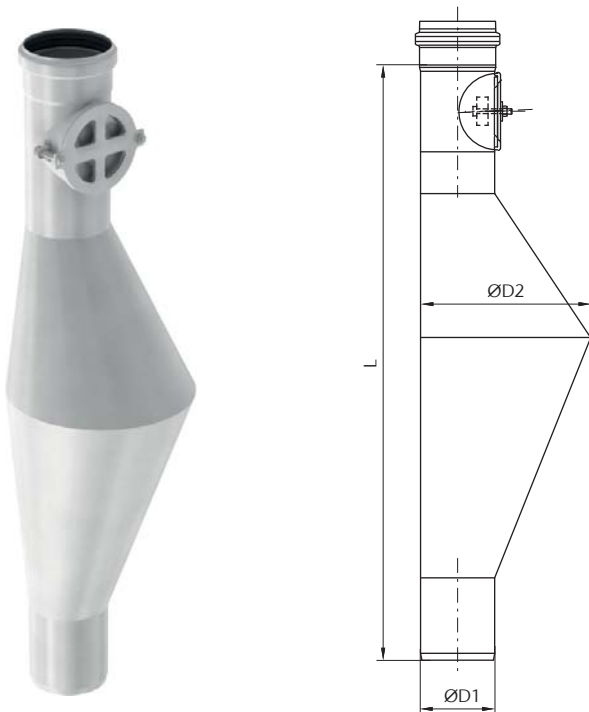

Seal material	Outlet diameter		Dimensions L [mm]	Weight [kg]	Item number	
	ØD1 [mm]	ØD2 [mm]			1.4301	1.4404
EPDM	110	250	864	3.8	419268	419270

Socket plug

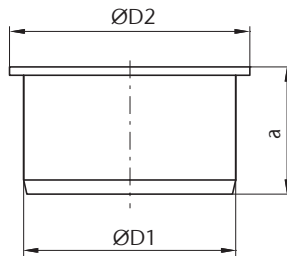

Outlet diameter		Dimensions	Weight	Item number
ØD1 [mm]	ØD2 [mm]	a [mm]	[kg]	1.4404
40	35	50	0.1	417405
50	58	45	0.1	98888
75	85	45	0.3	98889
110	120	45	0.5	98890
125	135	50	0.6	419782
160	170	50	0.5	98891
200	210	50	0.7	98994
250	260	83	1.0	417131
315	325	73	2.2	417215

Socket plug with clamp

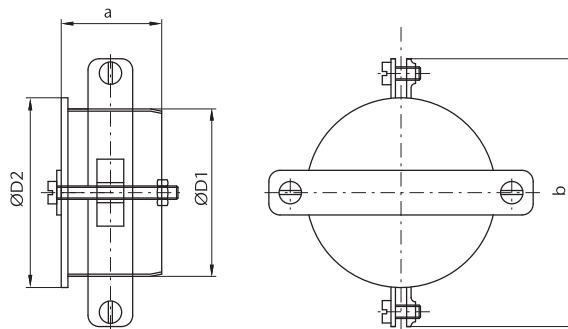

Outlet diameter		Dimensions		Weight	Item number
ØD1 [mm]	ØD2 [mm]	a [mm]	b [mm]	[kg]	1.4404
40					417402
50	58	45	88	0.4	419138
75	85	45	120	0.6	419139
110	120	45	167	0.8	419140
160	170	50	214	1.1	419141
250	260	83	302	1.3	417132
315	325	130	371	3.7	417216

Drainplugs with screwed plug

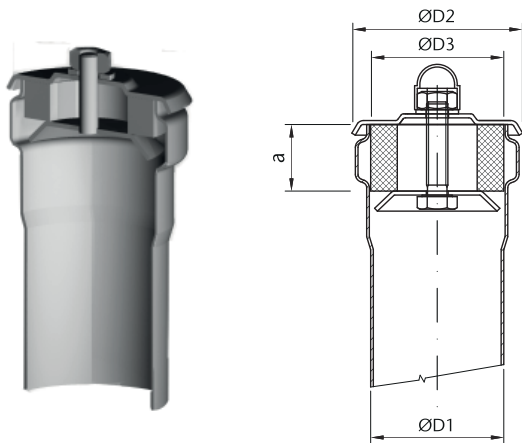

Outlet diameter		Dimensions		Weight [kg]	Item number	
ØD1 [mm]	ØD2 [mm]	ØD3 [mm]	a [mm]		1.4301	1.4404
40				0.1	417404	-
50	64	50	25	0.1	419942	419948
75	92	75	25	0.5	419943	419949
110	126	105	15	0.5	419944	419950
125	160	124	12	0.9	419945	419951
160	186	166	20	1.2	419946	419952

Vent cowl

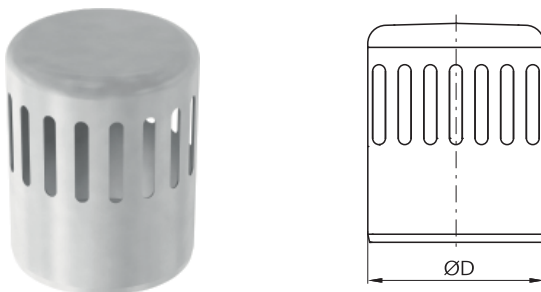

Outlet diameter ØD [mm]	Weight [kg]	Item number
110	0.4	98962

Socket clamp

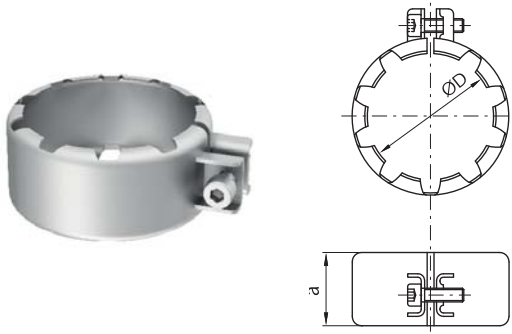

Outlet diameter	Dimensions	Weight	Item number
øD [mm]	a [mm]	[kg]	1.4404
50	40	0.11	417067
75	43	0.16	417069
110	43	0.25	417227

Note: See page 224 for maximum operating pressures

Socket clamp - two parts

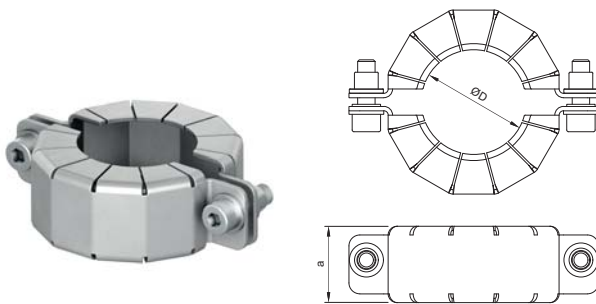

Outlet diameter	Dimensions	Weight	Item number	Item number
øD [mm]	a [mm]	[kg]	1.4301	1.4404
40	36	0.10	417396	417397
50	40	0.14	417024	417025
75	40	0.25	417026	417027
110	43	0.34	417028	417029
125	45	0.38	417016	417017
160	45	0.48	417030	417031
200	45	0.51	–	419983
250	45	0.71	–	417137
315	48	0.9	417219	–

Note: See page 224 for maximum operating pressures

Seal



Outlet diameter	Weight	Item number	Item number	Item number
øD [mm]	[kg]	EPDM	NBR	Viton®
40	0.01	417400	417401	417538
50	0.01	98400	417037	98404
75	0.02	98401	417038	98405
110	0.05	98402	417039	98406
125	0.06	419453	417041	419454
160	0.08	98403	417040	98407
200	0.10	98433	417042	98437
250	0.12	417146	417148	417147
315	0.30	417222	417223	–

Note: Detailed technical data sheet on page 259

Reduction sealing cast iron spigot → ACO pipe socket

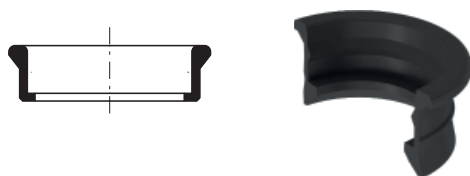

Outlet diameter	Weight	Item number
øD [mm]	[kg]	EPDM
DN 70/75	0.06	400580
DN 100/110	0.10	400581
DN 150/160	0.14	400582

Note: While purchasing AP reduction sealing cast iron spigot @ ACO pipe, it is necessary to order AP cast iron connector.

Reduction sealing ACO pipe spigot → cast iron socket

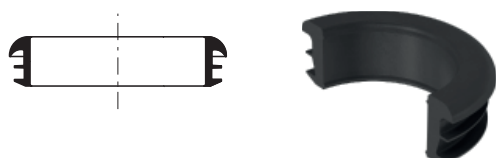

Outlet diameter	Weight	Item number
øD [mm]	[kg]	EPDM
DN 70/75	0.05	400586
DN 100/110	0.08	400587
DN 150/160	0.12	400588

ACO Universal lubricant

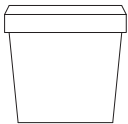
	Weight [kg]	Item number
	0.15	E80350000
	1.00	E80350001

Fixing plate

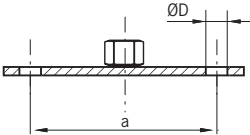
	Outlet diameter øD [mm]	Dimensions a [mm]	Weight [kg]	Item number Galvanised steel	Item number 1.4404
	8.4	70	0.05	400525	400521

Support bracket with rubber infill

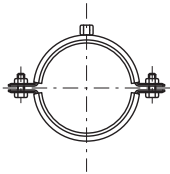
	Outlet diameter øD [mm]	Weight [kg]	Material	Nut size	Item number
	40	0.12	Galvanised steel	M8	417434
			1.4404	M8	417359
	50	0.14	Galvanised steel	M8	400533
			1.4404	M8	400529
	75	0.23	Galvanised steel	M8/M10	400534
			1.4404	M8	400530
	110	0.33	Galvanised steel	M8/M10	400535
			1.4404	M8	400531
	125	0.36	Galvanised steel	M8/M10	419854
			1.4404	M8	419855
	160	0.39	Galvanised steel	M8/M10	400536
			1.4404	M8	400532
	200	0.44	Galvanised steel	M8/M10	419451
			1.4404	M8	419675
	250	0.60	Galvanised steel	–	–
			1.4404	M8	417149
315	1.0	Galvanised steel	–	–	
		1.4404	M12	417224	

Support bracket with rubber infill and stirrup

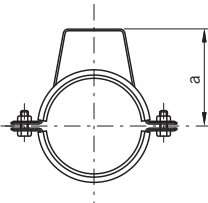
	Outlet diameter	Dimensions	Weight	Item number	Item number
	øD [mm]	a [mm]	[kg]	Galvanised steel	1.4404
	40			417358	417360
	50	56	0.18	400541	400537
	75	80	0.28	400542	400538
	110	116	0.41	400543	400539
	160	166	0.48	400544	400540

Support bracket with rubber infill and key

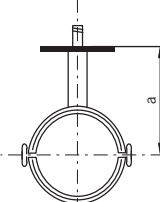
	Outlet diameter	Dimensions	Weight	Item number	Item number
	øD [mm]	a [mm]	[kg]	Galvanised steel	1.4404
	40			–	417361
	50	120	0.16	400549	400545
	75	133	0.26	400550	400546
	110	150	0.38	400551	400547
	160	175	0.44	400552	400548

Threaded support pole M8

	øD	L	Weight	Item number	Item number
	[mm]	[mm]	[kg]	Galvanised steel	1.4404
	M8	1000	0.39	400557	400553
	M8	90	0.03	400558	400554
	M8	40	0.016	400559	400555

Set for axial fixing

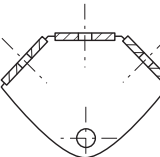
	Weight	Item number	Item number
	[kg]	Galvanised steel	1.4404
	0.11	400565	400561

Joiner/disjoiner

	$\varnothing D$ [mm]	Weight [kg]	Item number
	100 - 400	25	417070

Electric cutter 50 – 110 mm

	Note	Weight [kg]	Item number
	in plastic case	20	400745

Note: Convenient tool for pipe cutting, suitable for larger projects

Manual cutter set 50-110 mm

	Note	Weight [kg]	Item number
	in plastic case	3.50	419363

Manual cutter set

	$\varnothing D$ [mm]	Weight [kg]	Item number
	50–110	1.0	419364
	110–160	2.0	400738
	160–250	2.0	417228

Note: ACO pipe manual cutter should be ordered together with a holder for manual cutting.

Holder for manual cutting

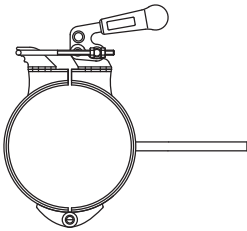
	øD	Weight	Item number
	[mm]	[kg]	
	125	3.5	419857
	160	4.0	400742
	200	4.5	400743

Note: ACO pipe holder for manual cutting should be ordered together with ACO pipe manual cutter.

Replacement discs for manual cutters

	Note	Weight	Item number
		[kg]	
	for cutter 419363	0.005	419365
	for cutters 400738 and 419364	0.005	400578

Note: Minimum order quantity – 10 pcs.

Full bore flow rate tables for varying gradients

For rainwater/storm drainage applications

- Flow rates based on Colebrook-White formula.
- Roughness coefficient $k_s = 0.6$ mm

Gradient [%]	Pipe ø 40 mm		Pipe ø 50 mm		Pipe ø 75 mm		Pipe ø 110 mm		Pipe ø 125 mm	
	Flow rate Q [l/s]	Velocity v [m/s]	Flow rate Q [l/s]	Velocity v [m/s]	Flow rate Q [l/s]	Velocity v [m/s]	Flow rate Q [l/s]	Velocity v [m/s]	Flow rate Q [l/s]	Velocity v [m/s]
10.0	1.44	1.28	2.74	1.52	8.40	2.01	23.81	2.60	33.61	2.83
7.5	1.25	1.11	2.38	1.31	7.28	1.74	20.62	2.25	29.11	2.45
5.0	1.01	0.90	1.94	1.07	5.94	1.42	16.83	1.84	23.77	2.00
4.5	0.96	0.86	1.84	1.02	5.64	1.35	15.97	1.74	22.55	1.90
4.0	0.90	0.81	1.73	0.96	5.31	1.27	15.06	1.64	21.26	1.79
3.5	0.84	0.75	1.62	0.90	4.97	1.19	14.08	1.54	19.88	1.67
3.0	0.78	0.70	1.50	0.83	4.60	1.10	13.04	1.42	18.41	1.55
2.5	0.71	0.64	1.37	0.76	4.20	1.00	11.90	1.30	16.80	1.41
2.0	0.63	0.57	1.23	0.68	3.76	0.90	10.64	1.16	15.03	1.26
1.5	0.55	0.49	1.06	0.59	3.25	0.78	9.22	1.01	13.01	1.10
1.0	0.44	0.40	0.87	0.48	2.66	0.63	7.53	0.82	10.63	0.89

Gradient [%]	Pipe ø 160 mm		Pipe ø 200 mm		Pipe ø 250 mm		Pipe ø 315 mm	
	Flow rate Q [l/s]	Velocity v [m/s]	Flow rate Q [l/s]	Velocity v [m/s]	Flow rate Q [l/s]	Velocity v [m/s]	Flow rate Q [l/s]	Velocity v [m/s]
10.0	64.15	3.31	116.89	3.83	218.31	4.45	401.51	5.15
7.5	55.56	2.87	101.22	3.32	188.95	3.85	347.54	4.46
5.0	45.36	2.34	82.65	2.71	154.13	3.14	283.52	3.64
4.5	43.03	2.22	78.40	2.57	146.17	2.98	268.90	3.45
4.0	40.57	2.10	73.92	2.43	137.77	2.81	253.45	3.25
3.5	37.95	1.96	69.14	2.27	128.82	2.63	236.99	3.04
3.0	35.13	1.81	64.01	2.10	119.20	2.43	219.31	2.82
2.5	32.07	1.66	58.43	1.92	108.74	2.22	200.09	2.57
2.0	28.68	1.48	52.26	1.71	97.18	1.98	178.83	2.30
1.5	24.84	1.28	45.26	1.48	84.05	1.71	154.70	1.99
1.0	20.28	1.05	36.95	1.21	68.48	1.40	126.07	1.62

Note:

The flow rates shown above assume an unrestricted discharge from the pipe. For installations without an unrestricted discharge, the flow rate will be affected by the downstream throttle.

For shallow gradients, the Colebrook-White formula underestimates flow rates (because when gradient tends towards zero %, velocity also tends to zero).

For level or nearly level installations (slope < 1 %), spatially varied flow tables should be used.

For soil/foul water drainage applications

- Flow rates based on Colebrook-White formula.
- Roughness coefficient $k_s = 0.6$ mm

Gradient	Pipe ø 40 mm		Pipe ø 50 mm		Pipe ø 75 mm		Pipe ø 110 mm		Pipe ø 125 mm	
	Flow rate	Velocity	Flow rate	Velocity	Flow rate	Velocity	Flow rate	Velocity	Flow rate	Velocity
[%]	Q [l/s]	v [m/s]	Q [l/s]	v [m/s]	Q [l/s]	v [m/s]	Q [l/s]	v [m/s]	Q [l/s]	v [m/s]
10.0	1.21	1.08	2.30	1.27	7.14	1.71	20.45	2.23	28.97	2.44
7.5	1.04	0.93	1.99	1.10	6.19	1.48	17.71	1.93	25.09	2.11
5.0	0.85	0.76	1.63	0.90	5.05	1.21	14.46	1.58	20.49	1.72
4.5	0.81	0.72	1.54	0.85	4.79	1.14	13.72	1.50	19.43	1.64
4.0	0.76	0.68	1.46	0.80	4.52	1.08	12.94	1.41	18.32	1.54
3.5	0.71	0.64	1.36	0.75	4.23	1.01	12.10	1.32	17.14	1.44
3.0	0.66	0.59	1.26	0.70	3.91	0.93	11.20	1.22	15.87	1.34
2.5	0.60	0.54	1.15	0.64	3.57	0.85	10.23	1.12	14.49	1.22
2.0	0.53	0.48	1.03	0.57	3.19	0.76	9.15	1.00	12.96	1.09
1.5	0.46	0.42	0.89	0.49	2.77	0.66	7.92	0.86	11.22	0.94
1.0	0.37	0.34	0.73	0.40	2.26	0.54	6.47	0.71	9.16	0.77

Gradient	Pipe ø 160 mm		Pipe ø 200 mm		Pipe ø 250 mm		Pipe ø 315 mm	
	Flow rate	Velocity	Flow rate	Velocity	Flow rate	Velocity	Flow rate	Velocity
[%]	Q [l/s]	v [m/s]	Q [l/s]	v [m/s]	Q [l/s]	v [m/s]	Q [l/s]	v [m/s]
10.0	55.61	2.87	101.81	3.34	206.87	4.22	382.95	4.92
7.5	48.16	2.49	88.17	2.89	177.84	3.62	329.47	4.23
5.0	39.32	2.03	71.99	2.36	143.52	2.93	266.21	3.42
4.5	37.30	1.93	68.30	2.24	135.71	2.77	251.81	3.23
4.0	35.17	1.82	64.39	2.11	127.46	2.60	236.59	3.04
3.5	32.90	1.70	60.23	1.98	118.69	2.42	220.42	2.83
3.0	30.46	1.57	55.76	1.83	109.29	2.23	203.07	2.61
2.5	27.80	1.44	50.90	1.67	99.10	2.02	184.25	2.37
2.0	24.87	1.28	45.53	1.49	87.86	1.79	163.50	2.10
1.5	21.53	1.11	39.43	1.29	75.18	1.53	140.05	1.80
1.0	17.58	0.91	32.19	1.06	60.25	1.23	112.42	1.44

Note:

The flow rates shown above assume an unrestricted discharge from the pipe. For installations without an unrestricted discharge, the flow rate will be affected by the downstream throttle.

For shallow gradients, the Colebrook-White formula underestimates flow rates (because when gradient tends towards zero %, velocity also tends to zero).

For level or nearly level installations (slope < 1 %), spatially varied flow tables should be used.

Operating pressures

The ACO pipe socketed stainless steel pipe systems are fitted with a unique, double lip seal manufactured from either EPDM or Viton®.

The double lip seal arrangement provides added security for the ultimate long term reliability. The ACO pipe; socketed stainless steel pipe systems are tested and approved for operating pressures in gravity, siphonic and vacuum systems.

ACO pipe stainless steel pipe systems are designed for maximum working pressure 0.5 bar according to EN 1124. In case where higher pressure may apply, it is necessary to combine the system with socket clamps.

Pipe diameter [mm]	Operating pressure [bar]	
	■ Without socket clamp	■ With socket clamp
40	0.5	2.5
50	0.5	2.5
75	0.5	2.5
110	0.5	2.5
125	0.5	2.5
160	0.5	1.5
200	0.5	1.5
250	0.5	1.0
315	0.5	0.7

Vacuum applications

Pipe diameter [mm]	Operating pressure [bar]
40	-0.8
50	-0.8
75	-0.8
110	-0.8
125	-0.8
160	-0.8
200	-0.8
250	-0.8
315	-0.8

Notes:

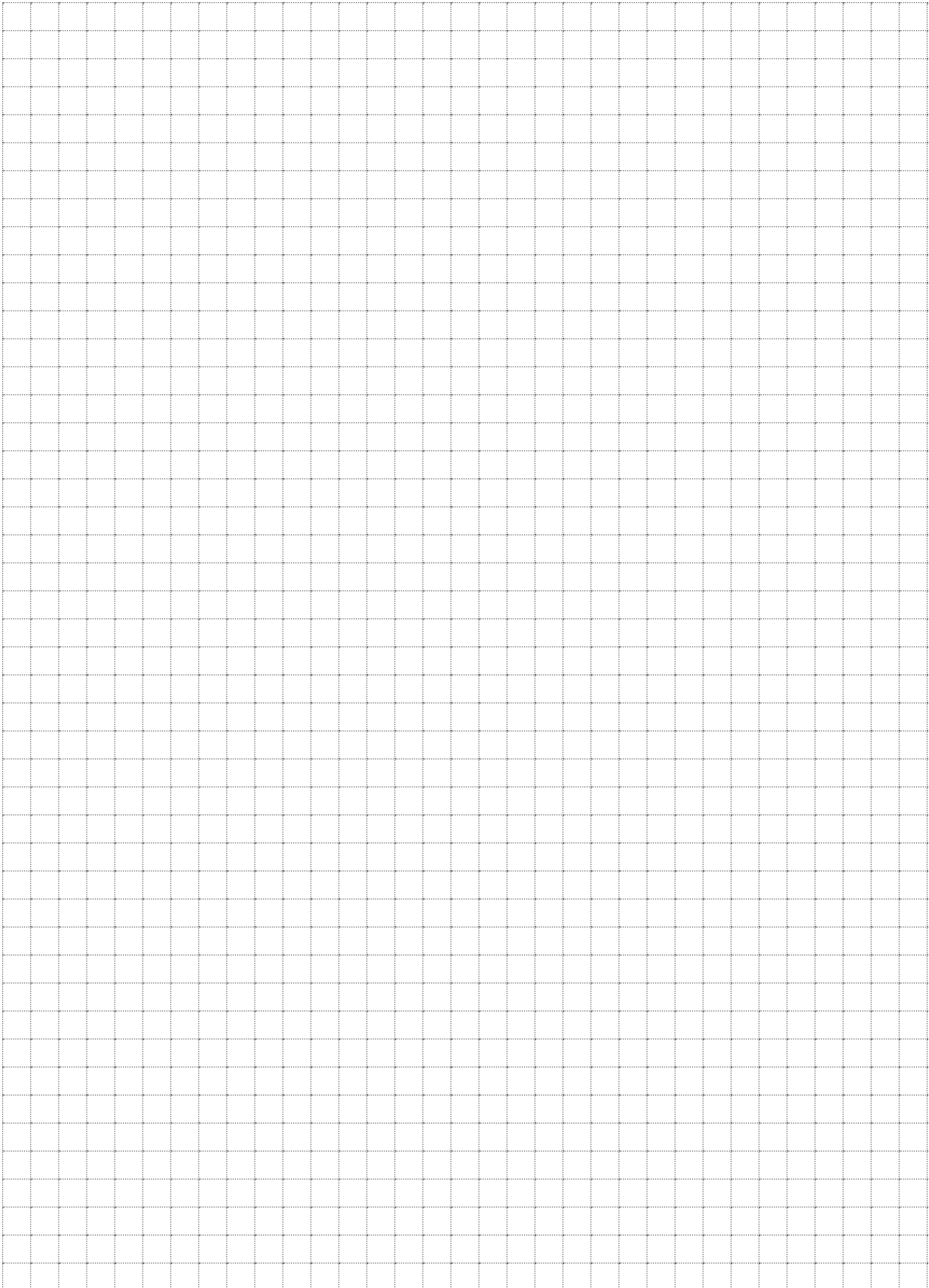



5

ACO Industrial Drainage Support

COLLECT:
Collect and remove



ACO Industrial Drainage Support

Transport & handling	Transport & handling information	238
	ACO gullies and ACO channels - Introduction	240
ACO fire protective solution	ACO gullies and ACO channels - Installation and function	241
	ACO pipes - Installation and function	242
Cleaning procedures	Introduction	244
	Principles of cleaning	245
	Cleaning chemicals	246
	Manual cleaning of drainage	247
	Chemical cleaning of drainage	248
	Overview with recommended cleaning procedures for drainage	249
	ACO hygienic gully	250
Typical installation examples	ACO hygienic box channel	253
	ACO vinyl box channel	255
	ACO modular box channel	256
	ACO modular slot channel	259
	ACO pipe	261
	ACO protective covers	264
Material	Resistance of Material	266
	Sealing material information	269



Discover more in a 3D environment:
buildingdrainage.aco/products

Online
information



Transport & handling information

ACO gully

- ACO gullies are packed on framed pallets, protected by cardboard inserts and PE foil. Individual products are packed in protective plastic net.
- Outlet pipes are equipped with protective lids.
- Gully tops and flanges are covered with protective blisters, which also protect the inside areas during installation. Individual products are packed in plastic protective net.
- Handle the gully/ gully parts with care. Any rough manipulation (like dragging along the ground, dumping off the truck...) can cause deformation and potentially cause product malfunctions.
- Contact with carbon steel may cause stainless steel corrosion.

ACO channel

- The maximum transportable length of channel is 6 000 mm. In case of container or air transport, the recommended maximum transport length is 2 000 mm. Long channels over 6 000 mm are standardly divided in 6 m sections with transport joints.
- If one piece channel is required, the channel will have to be welded on site. Please contact our Sales/Technical department.
- ACO channel is for such requirement packed on framed/ non framed pallets fixed by plastic tape.
- Products are protected by wooden inserts and frames, in some cases PE foil or bubble foil is used.
- Articles are either wrapped separately in ACO paper box or placed loose within EUR pallet space. It is strongly recommended that channels / channel parts / accessories are transported in their original packaging to avoid damage and / or loss of parts.
- Store preferably on dry and flat surface.
- Handle the channels/ channel parts/ accessories with care. Careful truck un/loading procedures are crucial. Any rough manipulation (like dragging along the ground, dumping off the truck etc...) can cause deformation and potentially cause product malfunctions.
- Contact with carbon steel may cause stainless steel corrosion.

ACO grating

- Standard grating length for ACO hygienic box channel is 500 mm and 1 000 mm for ACO modular box channel.
- ACO grating is packed on framed pallets protected by cardboard inserts and PE foil.
- Articles are either wrapped separately in ACO paper box or placed loose within EUR pallet space.
- It is strongly recommended to transport gratings in their original packaging to avoid damage. Store preferably on dry and flat surface.
- Handle the gratings with care.
- Any rough manipulation (like dragging along the ground, dumping off the truck...) can cause deformation and potentially cause product malfunctions.
- Contact with carbon steel may cause stainless steel corrosion.

ACO pipe

- Maximum transport length of straight pipes pallets is 6 080 mm and width 820 mm.
- Straight pipes are packed on framed/ non framed long pallets, protected by wooden inserts and supports.
- Articles are either wrapped in cardboard and stretch or PE foil. Fittings are packed in cardboard boxes and stacked on foiled EUR pallets.
- It is strongly recommended to transport and store the pipes and fittings in their original packaging to avoid damage and/or the loss of parts. Store preferably on dry and flat surface.
- Handle the pipes and fittings with care. Any rough handling (like dragging along the ground, dumping off the truck...) can cause deformation and potentially cause product malfunctions.
- Contact with carbon steel may cause stainless steel corrosion.

ACO gullies and ACO channels Introduction

ACO has developed a solution which prevents the spreading of fire and high temperatures within different building's floors where ACO hygienic gully, ACO hygienic channel and ACO pipe are installed.

The solution has been tested according to EN 1366-2 Fire resistance tests for service installations and classified according to EN 13501 Fire classifications of construction products and building elements. For classification details please see chart below.

ACO fire protective kit can be used with telescopic vertical or fixed height vertical ACO hygienic gully and with ACO hygienic box channel, consisting of following items:

- External protection – Fit in
- Internal protection
 - Fire protective foul air trap
 - Fire protective foul air trap support

This solution has been designed and tested for use in either concrete or aerated concrete ceiling slabs with a minimum height of 150 mm.

ACO hygienic gully and ACO hygienic box channel installed with ACO fire protective kit can be connected to any kind of sewerage with ACO pipe regardless of its material, e.g. non combustible cast iron drain pipes SML, stainless steel ACO pipe (building material class A1) or plastic drain pipes (building material class B1/B2). All mentioned components of external and internal protection must be used to guarantee correct function of fire protection!

Tested at: PAVUS, a.s. protocol: No. Pr-13-2.061

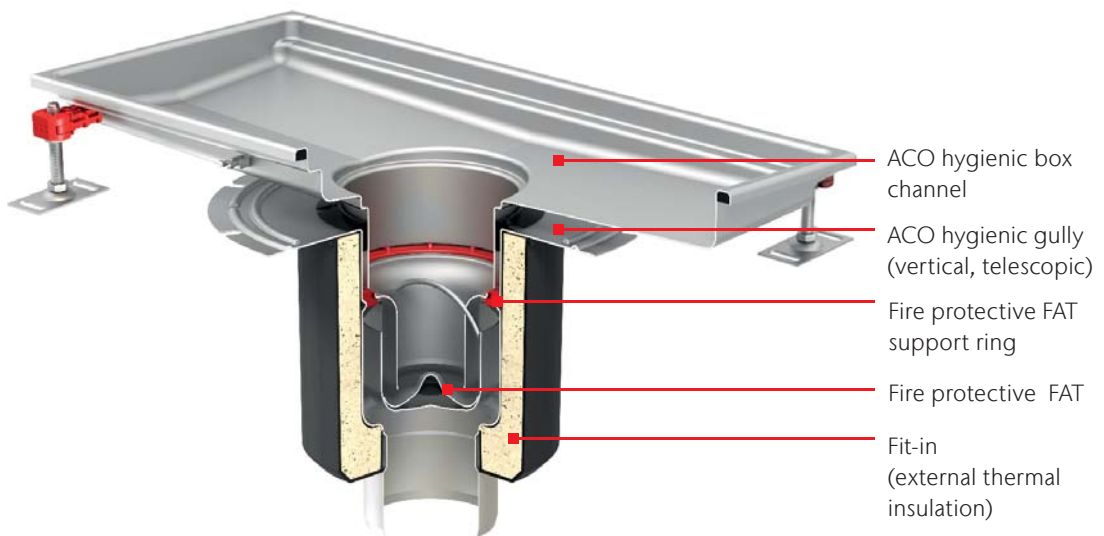

Gully type	Outlet diameter	Classification
■ ACO hygienic gully 142	75	EI 180
	110	EI 120
■ ACO hygienic gully 157	75	EI 180
	110	EI 120
■ ACO hygienic gully 218	110	EI 180
	160	EI 90

Classification according to EN 13501, protocol: PK2-11-13-901-C-0

ACO gullies and ACO channels Installation and function

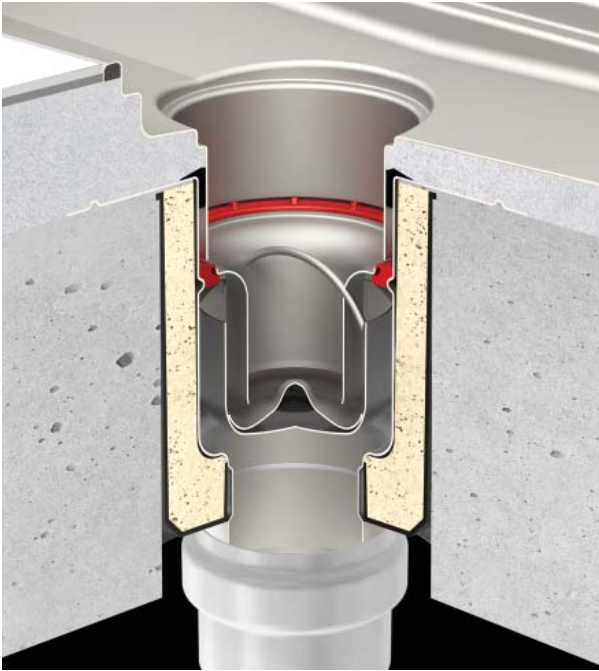

Before activation

- Installation scheme with assembled fire protective solution in ceiling construction.

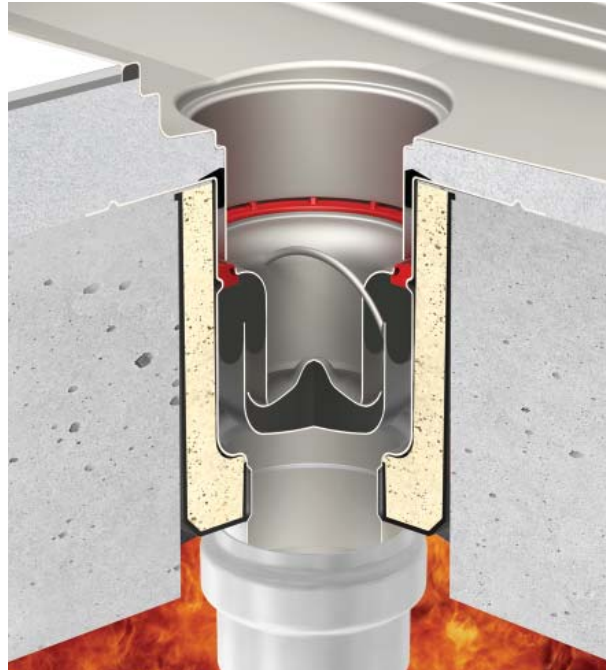

Fire activation

- Function of fire protective solution to prevent the spread of fire within storey structure by transmission (ACO gully).
- Time preventing the spread of fire is limited from 90 minutes to 180 minutes.

ACO pipe Installation and function

ACO pipe push-fit system is classified and certified as a non-combustible product (as it is manufactured in compliance to EN 1124, part 1 & part 2). This standard classifies the ACO pipe systems as class A1 fire resistant (highest rating).

ACO pipe systems are certified also by SITAC authority as fire resistant (cert. no. 0410-01).

Special certificate of fire resistance for coated pipes (no. CSI PK-13-083) is available.

Fire certificates from marine authorities are available.

Non combustibility:

- Non combustible
- No additional fire collars needed at installation
- No toxic fumes emitted in case of fire
- EN 1124

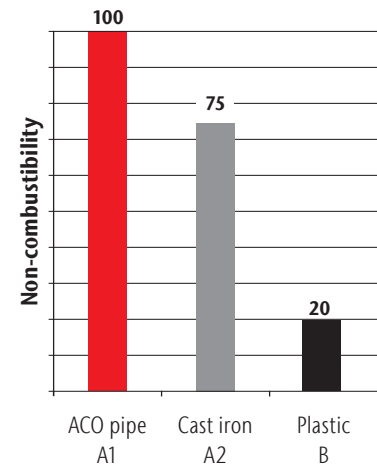
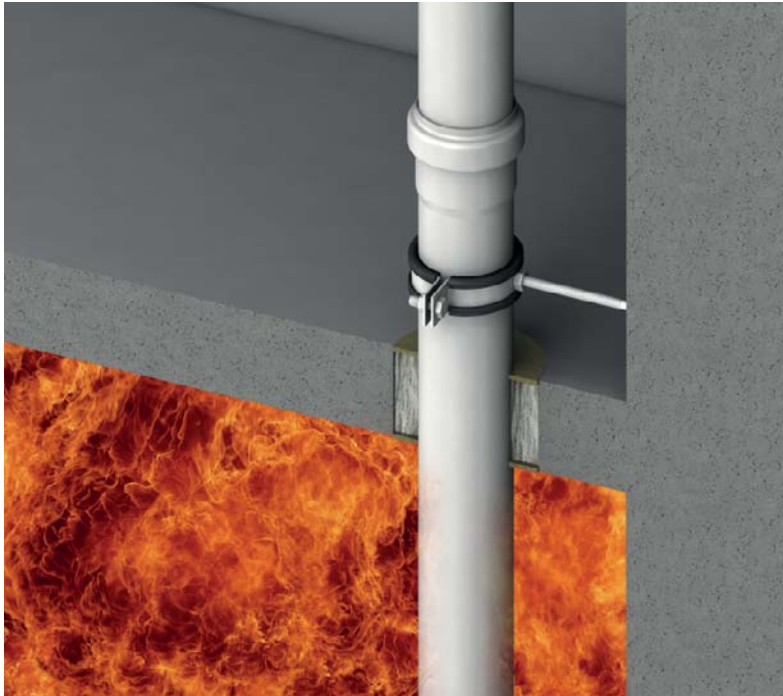

Notes:

A large grid of dotted lines for taking notes, consisting of 20 columns and 30 rows of small squares.

Introduction

Drainage is a critical component affecting the hygienic performance of commercial food preparation business. Effective drainage helps to mitigate hazards from the external environment and is central to the safe and hygienic operation internally. Within the food production facility, surface liquids represent potential hazard of microbiological contamination.

Liquids may be part of the cleaning process, or may originate from specific equipment discharge points, or be simply the result of an accidental spillage. Quite often the liquids contains other components – organic matter being predominant. Floor drainage components cater for these situations through three core functions - interception, conveyance of fluids, and ability to act as a barrier.

Effective cleaning of drainage in commercial food preparation business reduces risk of contamination and spoiling of food during preparation, processing, and storage. The main objective of cleaning is to remove soil to obtain clean surface and thereby reduce number of microorganisms. A further reduction of microorganism can be obtained by disinfection step.

Principles of cleaning

The principles of cleaning involve combination of thermal, kinetic and chemical energy. The cleaning processes are always combination of these factors and time of these to work. The key point to highlight is that all equipment – including

drainage – in food processing plant should have hygienic design, which is easy to clean and disinfect. Otherwise the cleaning process is time and energy consuming and not cost effective.

All surfaces of ACO stainless steel drainage are hygienically designed – no sharp corners, edges, dead spaces and crevices. ACO drainage is easily accessible for cleaning and visual inspection.

The effectiveness of drainage cleaning depends on number of factors:

- Soil type and properties
- Material, design and surfaces
- Water quality
- Cleaning chemicals
- Cleaning procedure
- Cleaning parameters; like temperature, time, flow velocity and concentration of chemicals

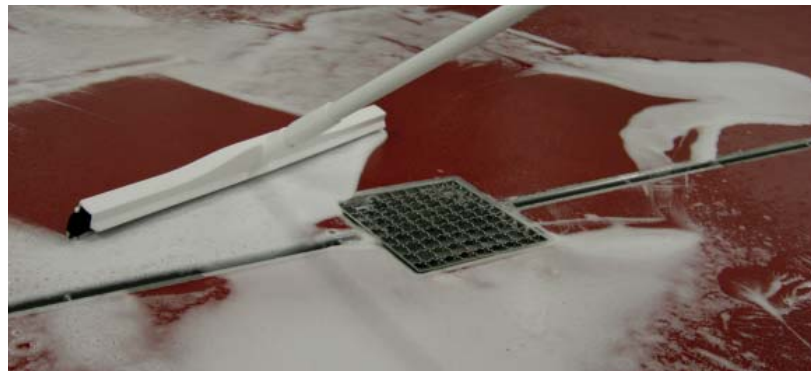

There are two different types of surface to be cleaned:

■ Product contact surface

All equipment that intentionally or unintentionally (e.g. due to splashing) comes to contact with final product or from which product or condensate may drain, drop or be drawn into the main product or product container.

■ Non product contact surface

All other exposed surfaces, including surfaces associated with equipment, such as support structures, control panels and external surfaces. It also includes surfaces related to the manufacturing environment, such as floors, walls and drain channels.

We also differentiate cleaning process as whether it is applied dry or wet.

■ Dry cleaning

Dry cleaning is essentially a mechanical removal of soils using sweeping, brushing, wiping and vacuuming. Environments typically to be cleaned by dry methods include plants which are producing flour, cocoa, dry milk products, dry soups and dry infant formulas.

■ Wet cleaning

Wet cleaning involves application of fluids (usually water based) to achieve the desired cleaning result. This can be applied to Open Plant Cleaning (OPC): surfaces to be cleaned have to be accessible to fluids. In addition, some components may be physically removed from production area and cleaned separately – Cleaning out of place (COP). Drainage systems require wet cleaning.

The last is a distinction between whether the cleaning process is done manually or automatically.

■ Manual cleaning

Manual cleaning is generally considered as labour intensive and, therefore often expensive. The manual tools should be hygienic – resistant to applied chemicals and suitable for a specific operation. On top of it; operators should be properly trained to be able to perform cleaning as expected to achieve clean surfaces. ACO drainage has all elements of hygienic design that makes cleaning of ACO drainage much easier and faster when compared to competitive products.

■ Automatic cleaning

Utensils and dismantled parts of equipment are cleaned and disinfected automatically in industrial washing machines, tray or tunnel washers (automatic COP). CIP is also defined as automatic cleaning system.

Cleaning chemicals

There are three main classes of cleaning compounds:

- detergents
- alkalis
- acids
- disinfectants/sanitizers

Detergents

This broad group of chemicals is widely used in households and in food industries brings different type of soil from surfaces into cleaning foams and emulsions that could be easily rinsed off.

Alkalies

Alkaline compounds are effective for dissolution of proteins and removal of fats. Example of alkalies are sodium hydroxide (caustic soda) and potassium hydroxide. These compounds are hazardous to personnel and mostly used in CIP – automatic dosing system is recommended.

Acids

Acids, both organic and inorganic, are commonly used for removal of mineral deposits, such as: hard water scale or milkstone. Acids are potentially corrosive to construction materials and must be used with care.

When chemical cleaning is performed, it is necessary to use low-pressure sprays, foam or gel. Foam and gel are more viscous than sprayed agents and preferred as they are not prone to aerosol formation. Selection of the correct detergent for given application should be always done in co-operation with the detergent supplier.

Disinfectants/sanitizers

In case of high risk areas or production areas with microbiological sensitive products, the floors and drain systems should be sprayed with disinfectants/sanitizers, which will reduce the contamination risk even more. The disinfectants/sanitizers will kill remaining micro-organisms, according to the required specifications.

The plant downtime and labour associated with cleaning is major cost of any food processing operation.

Sources of soil

Primary source of soil is from processed food product itself. Microbiological biofilms mainly contribute to the soil build ups on drainage surfaces. These films vary in their solubility depending upon such factors as heat effect, age, dryness, time, etc. It is essential that personnel involved in the cleaning process design have understanding of the nature of the soil to be removed before selecting a detergent and cleaning method. The rule of thumb is that acid cleaners dissolve alkaline soils (minerals), and detergents dissolve acid soils and food wastes (proteins).

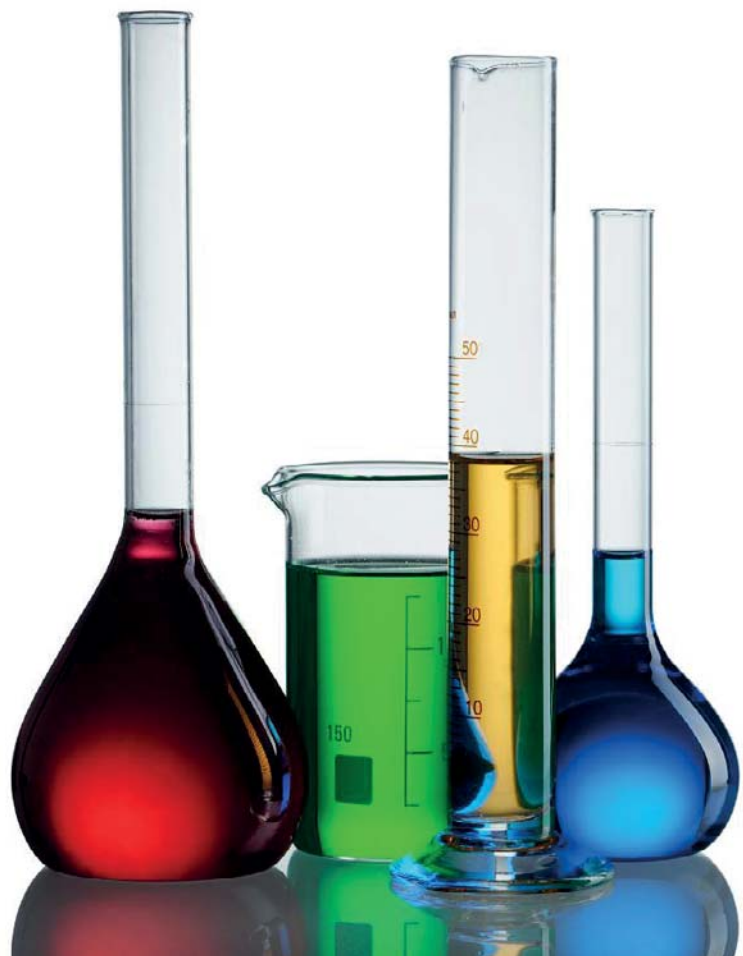



Manual cleaning of drainage

- 

1 Remove all present grocery, raw materials, wrapping materials and tools.
- 

2 Cover all equipment that could be contaminated.
- 

3 Remove excess dirt from floor and gratings, and place into designated container.
- 

4 Remove gratings.
- 

5 Remove and empty silt basket and foul air trap.
- 

6 Place collected waste and dirt into designated container. Rinse grating, silt basket and foul air trap with clean water. Then place foul air trap into its original position.
- 

7 Wash all surfaces with designated detergent and designated hand brush.
- 

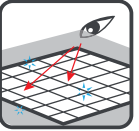
8 Rinse all surfaces with clean water.
- 

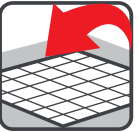
9 Visually check surface cleanliness - repeat cleaning process if necessary.
- 

10 Place silt basket and grating to its original position.
- 

11 Rinse the entire equipment with clean water.

Chemical cleaning of drainage

- 

1 Remove all present grocery, raw materials, wrapping materials and tools.
- 

2 Cover all equipment that could be contaminated.
- 

3 Remove excess dirt from floor and gratings; and place into designated container.
- 

4 Remove gratings.
- 

5 Remove and empty silt basket and foul air trap.
- 

6 Place collected waste and dirt into designated container. Rinse grating, silt basket and foul air trap with clean water. Then place foul air trap into its original position.
- 

7 Apply foam to all surfaces.
- 

8 Leave foam for 15 minutes.
- 

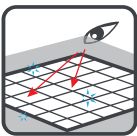
9 Rinse off foam with clean water.
- 

10 Visually check surface cleanliness - repeat cleaning process if necessary.
- 

11 Place silt basket and grating to its original position.
- 

12 Rinse the entire equipment with clean water.

Overview with recommended cleaning procedures for drainage

These instructions are for guidance only. **Always follow manufacturer's instructions.**
All procedures have to be verified and adjusted to the application specifics.

Frequency	Daily	Weekly
Procedure	Removal of organic deposits (fats, proteins, saccharides and polysaccharides)	Removal of inorganic deposits that could promote very resistant biofilms
Note: Removal of rinse water residues		
Physical agents	<ul style="list-style-type: none"> ■ Steam ■ Medium pressure water to max 25 bar ■ Mechanical / kinetic energy (brushes, CIP medium velocity) 	Mechanical abrasive methods – polishing
Note: Removal of excess water with a squeegee		
Chemical agents	<ul style="list-style-type: none"> ■ Caustics (sodium hydroxide, potassium hydroxide) ■ Detergents / surfactants 	<ul style="list-style-type: none"> ■ Nitric acid for stainless steel passivation where chlorine attack could be expected ■ Inorganic acids (phosphoric acid) ■ Weak organic acids
Note: Alcohols (isopropylalcohol, ethanol)		
Examples of chemical cleaning agents suitable for ACO stainless steel drainage	Standard chemical agents used for floor cleaning should be sufficient (should be validated) Oxofeam, Endorochlor (Diversey)	<ul style="list-style-type: none"> ■ Acifoam (Diversey) ■ Acigel (Diversey) ■ Super Dilac (Diversey)
Note: Chlorine tablets (Suma Tab D4 by Diversey) are often added to the water in foul trap in microbial sensitive production area's		

Any cleaning procedures, including those recommended by equipment suppliers, must be properly validated at the equipment, where it will be applied and on the soil that could be expected even after certain time of usage.

Always follow manufacturer's instructions to avoid damage to the equipment.

ACO hygienic gully

ACO hygienic gully – telescopic flanged gully installed in suspended concrete slab construction

- 1** Ceramic tiles
- 2** Tile cement
- 3** Mastic sealant
- 4** Floor screed
- 5** Water proof membrane (WPM)
- 6** Gully
- 7** Suspended concrete slab core-boarded to accept gully body

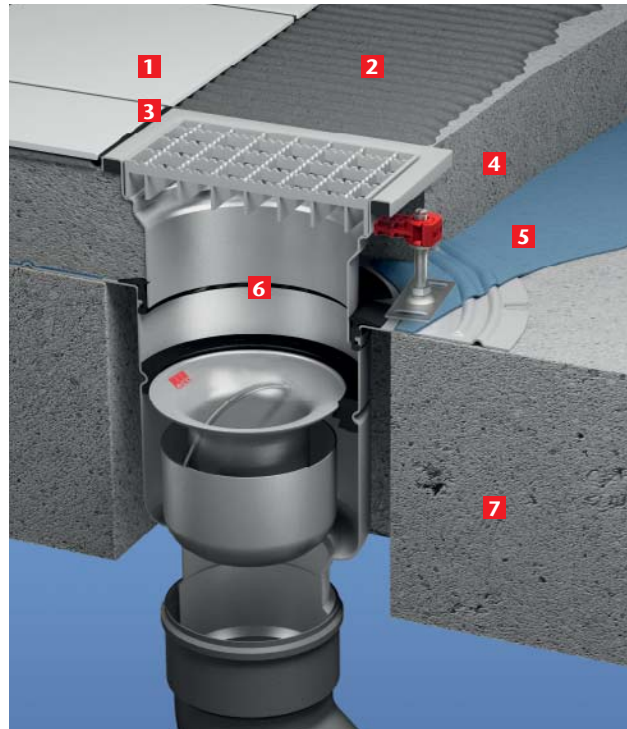

ACO hygienic gully – telescopic flanged gully and raising flanged piece installed in suspended concrete slab construction

- 1** Ceramic tiles
- 2** Tile cement
- 3** Mastic sealant
- 4** Floor screed
- 5** Water proof membrane (WPM)
- 6** Insulation
- 7** Double flange gully
- 8** Suspended concrete slab core-boarded to accept gully body

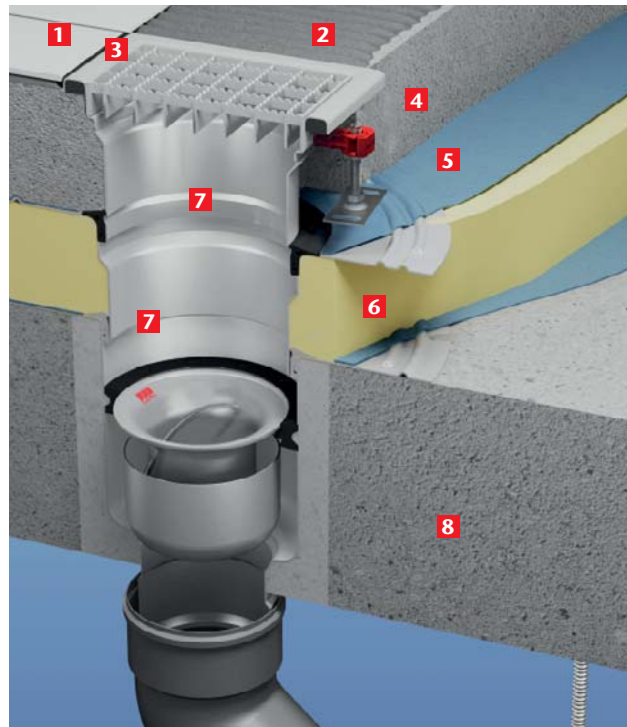

ACO hygienic gully – telescopic flanged gully installed in solid concrete floor

- 1** Ceramic tiles
- 2** Tile cement
- 3** Mastic sealant
- 4** Floor screed
- 5** Water proof membrane (WPM)
- 6** Flange gully
- 7** Solid concrete floor slab
- 8** Compacted soil

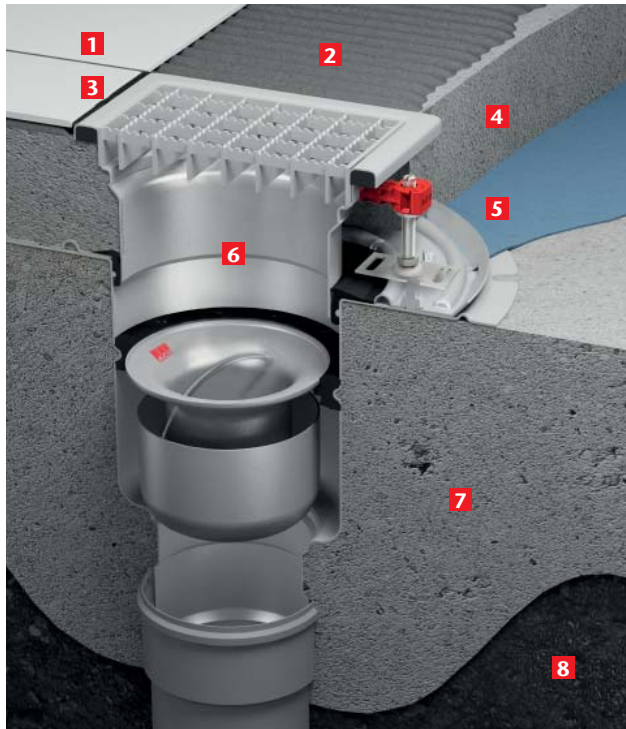

ACO hygienic gully – telescopic flanged gully and raising piece installed in solid concrete floor

- 1** Ceramic tiles
- 2** Tile cement
- 3** Mastic sealant
- 4** Floor screed
- 5** Water proof membrane (WPM)
- 6** Insulation
- 7** Double flange gully
- 8** Solid concrete floor slab
- 9** Compacted soil

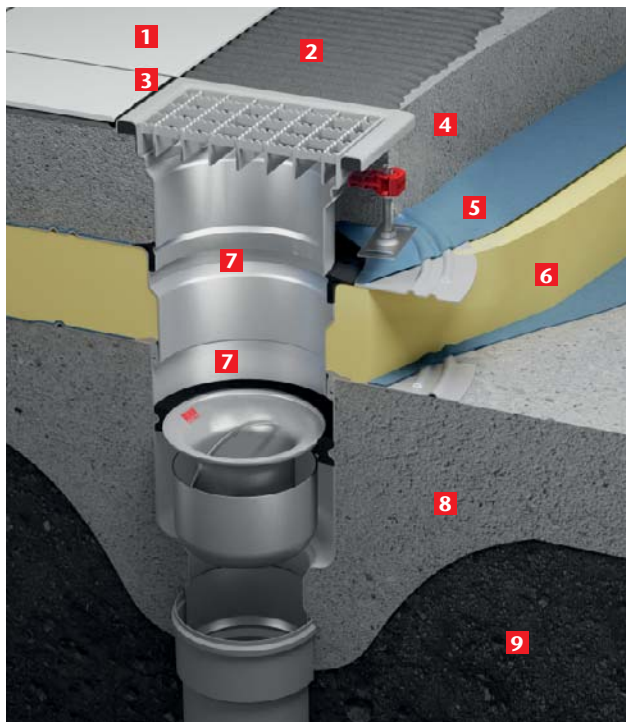

ACO hygienic gully – fixed height gully installed in solid concrete floor

- 1** Ceramic tiles
- 2** Tile cement
- 3** Mastic sealant
- 4** Floor screed
- 5** Dampf proof membrane (DPM)
- 6** Gully
- 7** Outlet pipe
- 8** Floor slab
- 9** Compacted soil

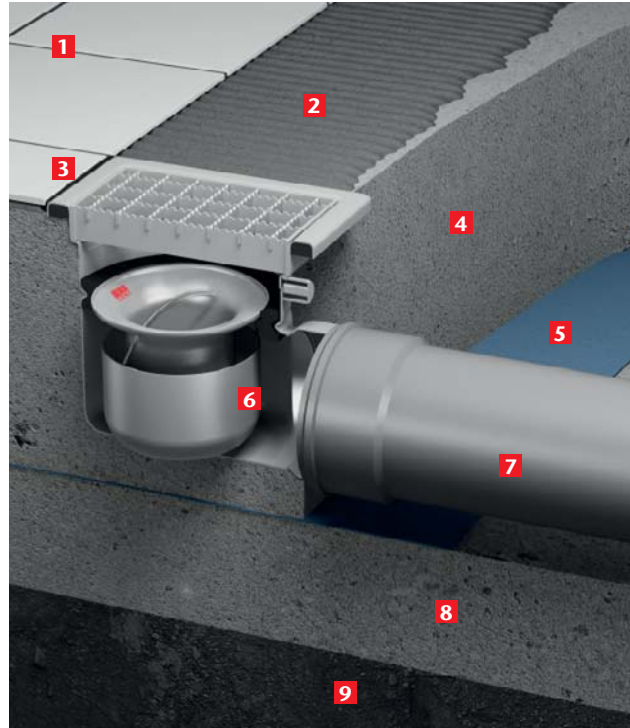

ACO hygienic box channel

ACO hygienic box channel standard type – ACO hygienic gully with adhesive bonding flange (Tiled floor)

- 1** Ceramic tiles
- 2** Tile cement
- 3** Mastic sealant
- 4** Rubber infill
- 5** Floor screed
- 6** Water proof membrane
- 7** Solid concrete floor slab

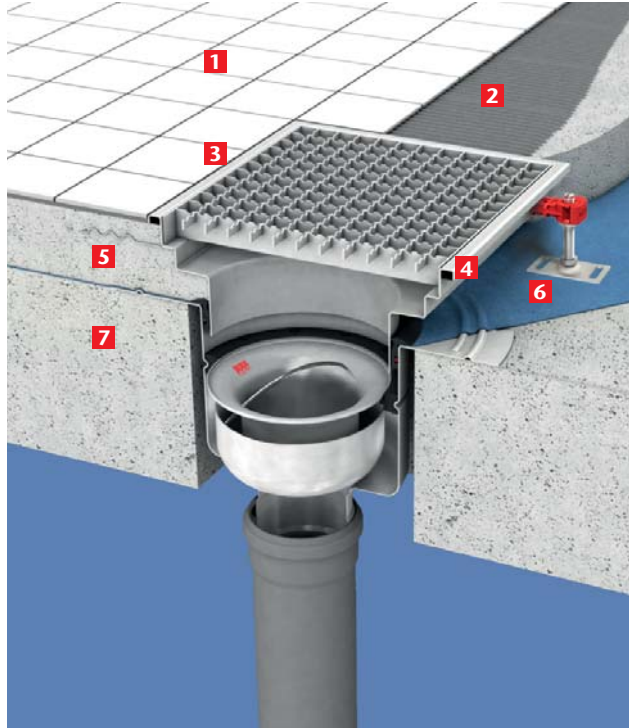

ACO hygienic box channel standard type – ACO hygienic gully with mechanical clamping flange (Tiled floor)

- 1** Ceramic tiles
- 2** Tile cement
- 3** Mastic sealant
- 4** Rubber infill
- 5** Floor screed
- 6** Water proof membrane
- 7** Solid concrete floor slab
- 8** Compacted soil

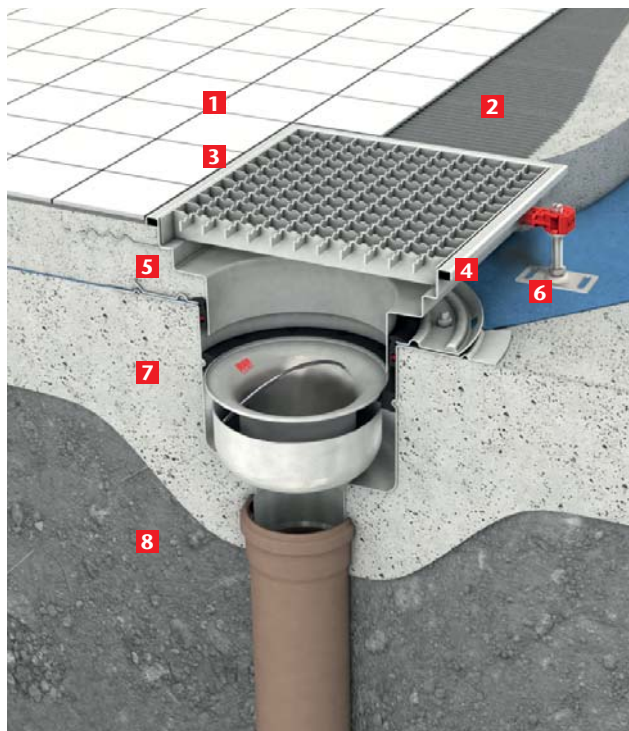

ACO hygienic box channel standard type – ACO hygienic gully with location flange (Resin floor)

- 1** Epoxy/resin floor
- 2** Floor screed
- 3** Rubber infill
- 4** Solid concrete floor slab
- 5** Compacted soil

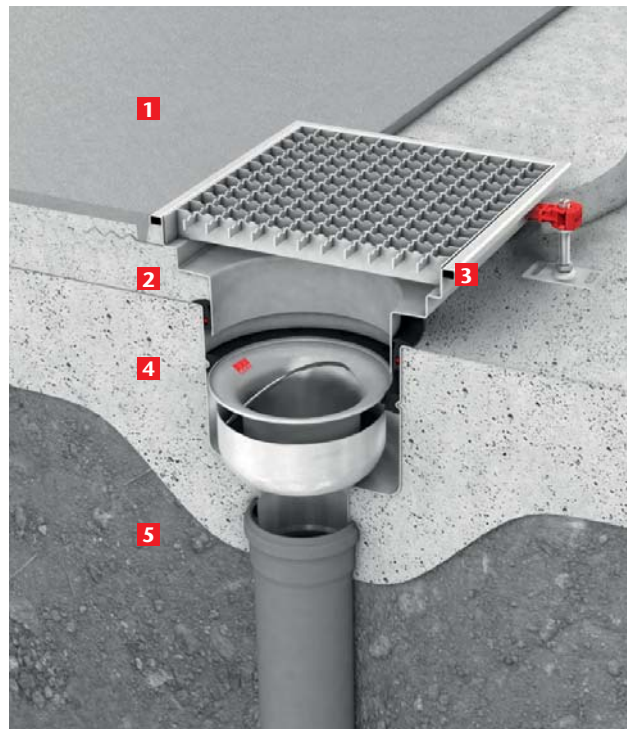

ACO hygienic box channel extendend type – ACO hygienic gully with location flange (Tiled floor)

- 1** Ceramic tiles
- 2** Tile cement
- 3** Mastic sealant
- 4** Rubber infill
- 5** Water proof membrane
- 6** Floor screed
- 7** Solid concrete floor slab
- 8** Compacted soil

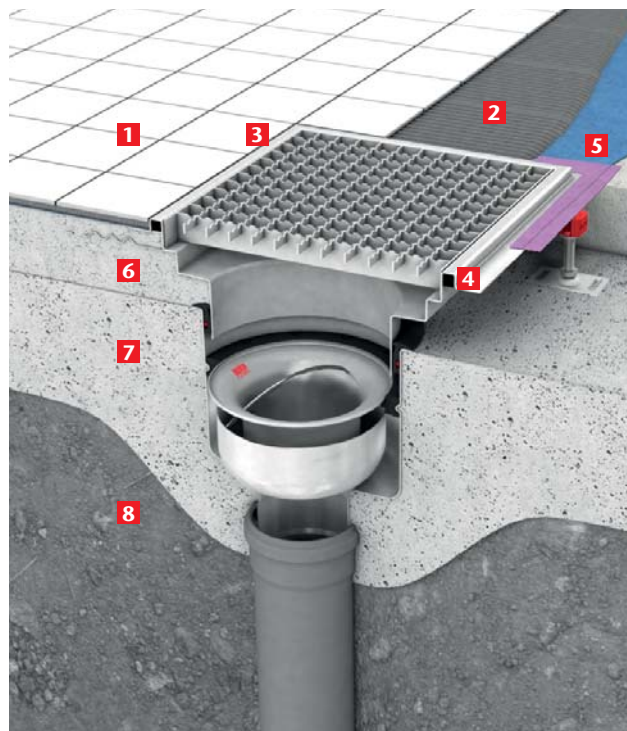

ACO vinyl box channel

ACO vinyl box channel – ACO hygienic gully with location flange (Vinyl floor)

- 1** Vinyl floor
- 2** Floor screed
- 3** Solid concrete floor slab
- 4** Compacted soil

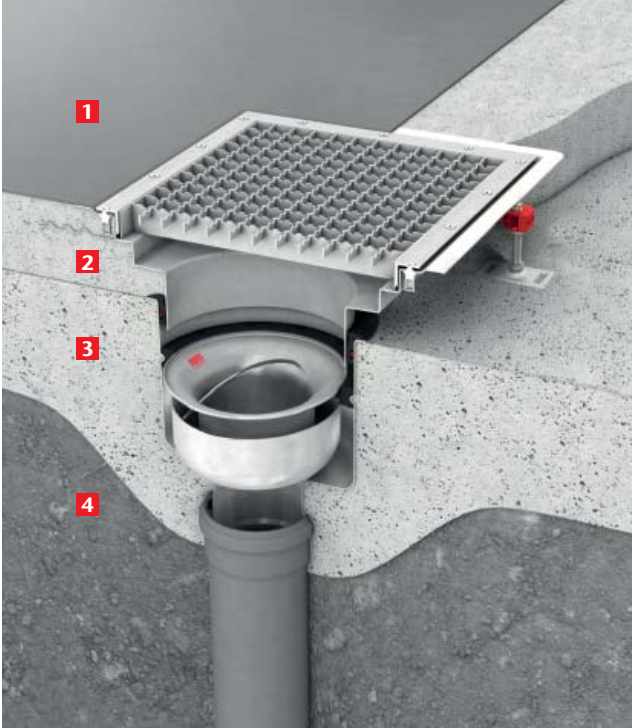

ACO modular box channel

ACO modular box channel standard type – ACO hygienic gully with adhesive bonding flange (Tiled floor)

- 1 Ceramic tiles
- 2 Tile cement
- 3 Mastic sealant
- 4 Rubber infill
- 5 Floor screed
- 6 Water proof membrane
- 7 Solid concrete floor slab

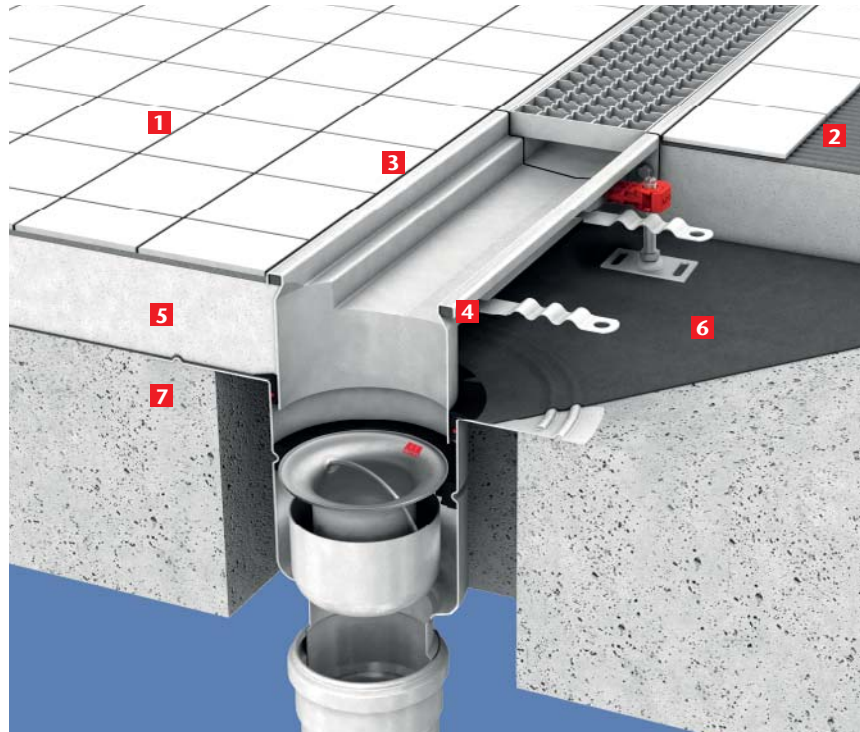

ACO modular box channel standard type – ACO hygienic gully with mechanical clamping flange (Tiled floor)

- 1 Ceramic tiles
- 2 Tile cement
- 3 Mastic sealant
- 4 Rubber infill
- 5 Floor screed
- 6 Water proof membrane
- 7 Solid concrete floor slab
- 8 Compacted soil

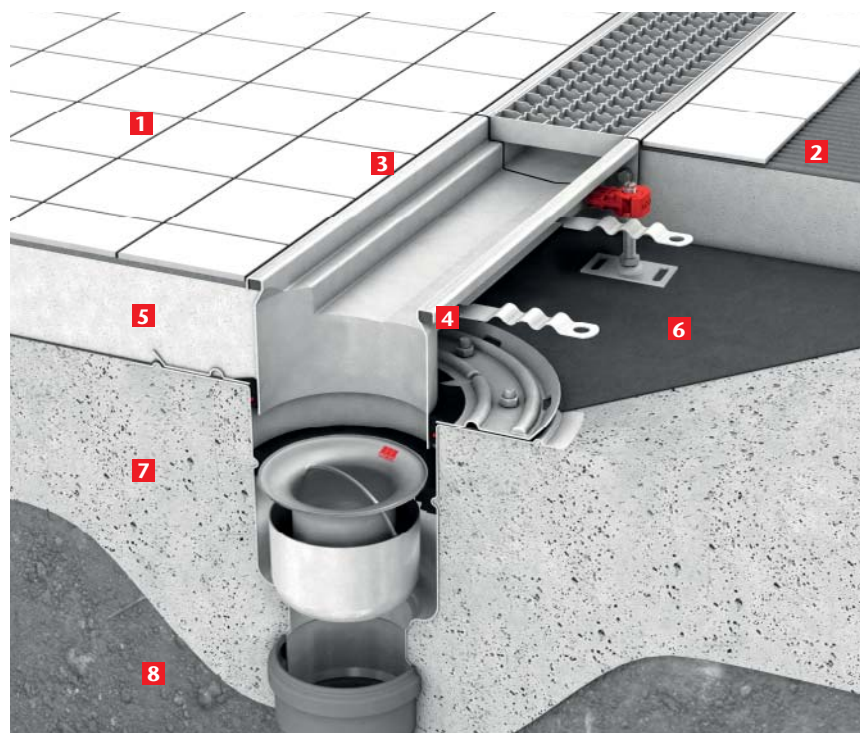

ACO modular box channel standard type – ACO hygienic gully with location flange (Resin floor)

- 1** Epoxy/resin floor
- 2** Floor screed
- 3** Rubber infill
- 4** Solid concrete floor slab
- 5** Compacted soil

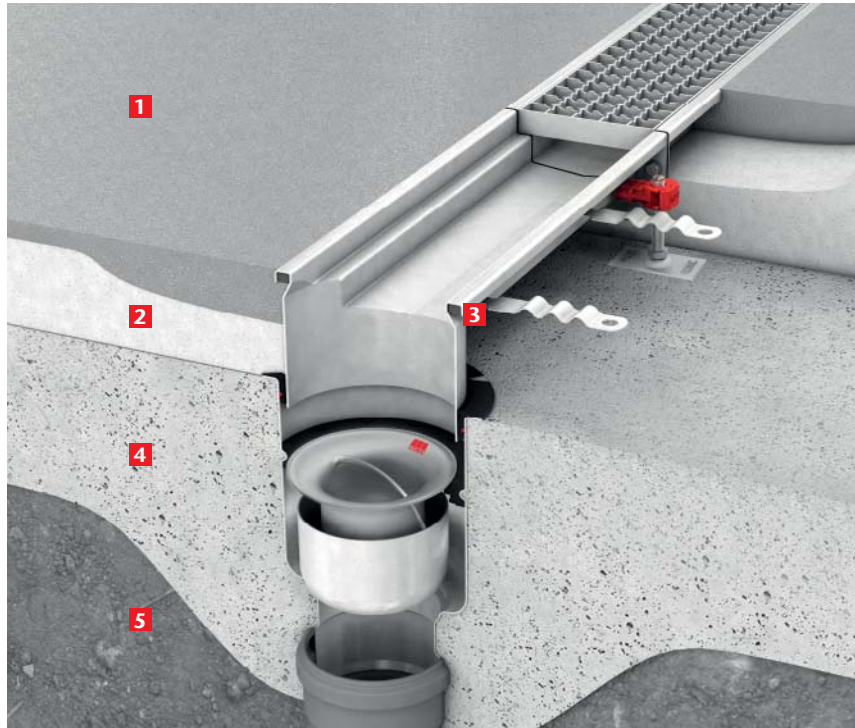

ACO modular box channel vinyl type – ACO hygienic gully with location flange (Vinyl floor)

- 1** Vinyl floor
- 2** Vinyl seal
- 3** Floor screed
- 4** Solid concrete floor slab
- 5** Compacted soil

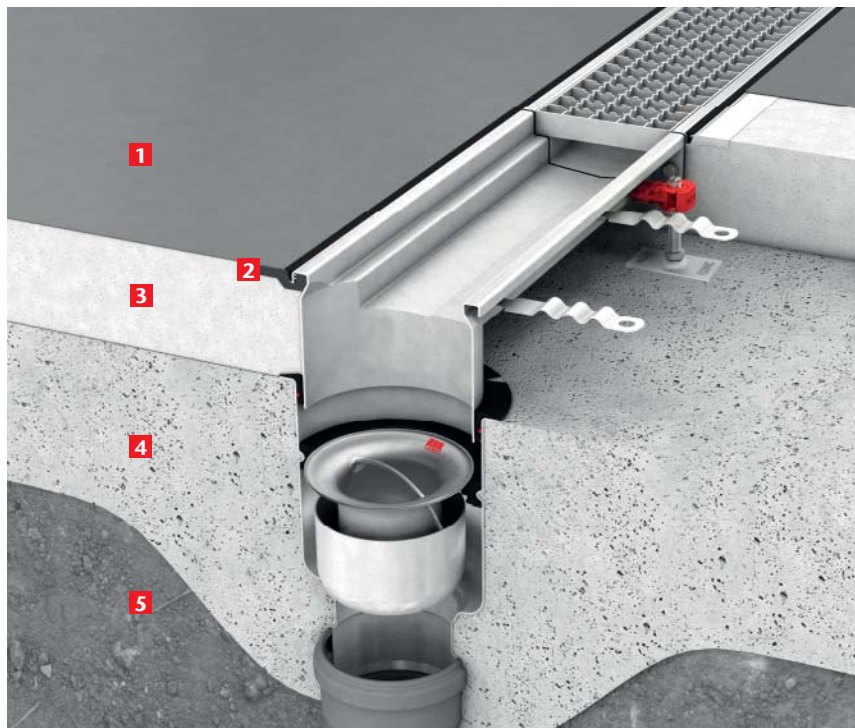

ACO modular box channel standard type – direct connection to sewage pipe system (Resin floor)

- 1** Epoxy/resin floor
- 2** Floor screed
- 3** Rubber infill
- 4** Solid concrete floor slab
- 5** Compacted soil

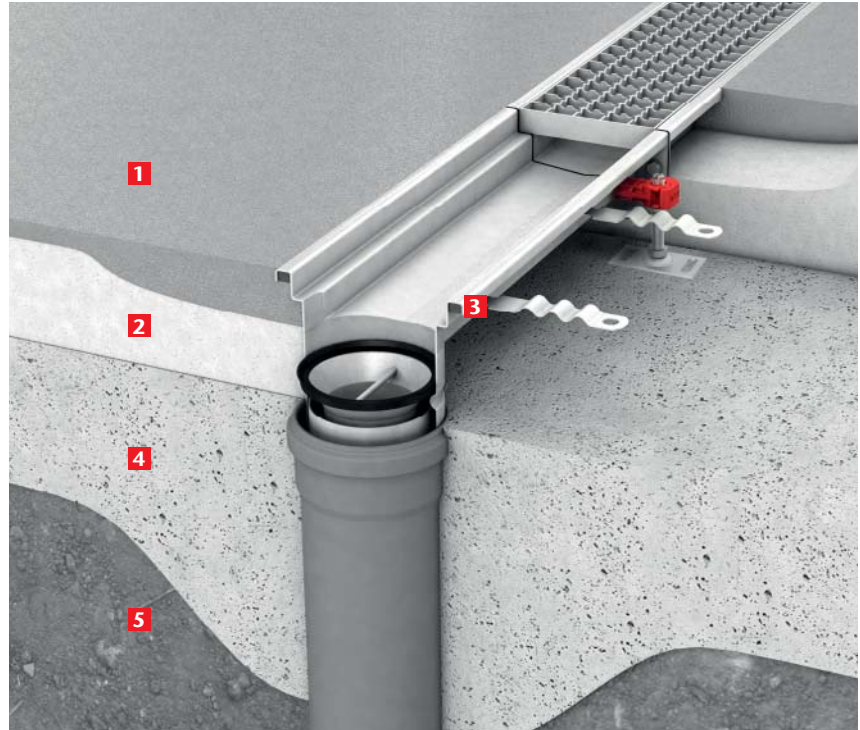

ACO modular slot channel

ACO modular slot channel standard type – ACO hygienic gully with adhesive bonding flange (Tiled floor)

- 1** Ceramic tiles
- 2** Tile cement
- 3** Mastic sealant
- 4** Rubber infill
- 5** Floor screed
- 6** Water proof membrane
- 7** Solid concrete floor slab

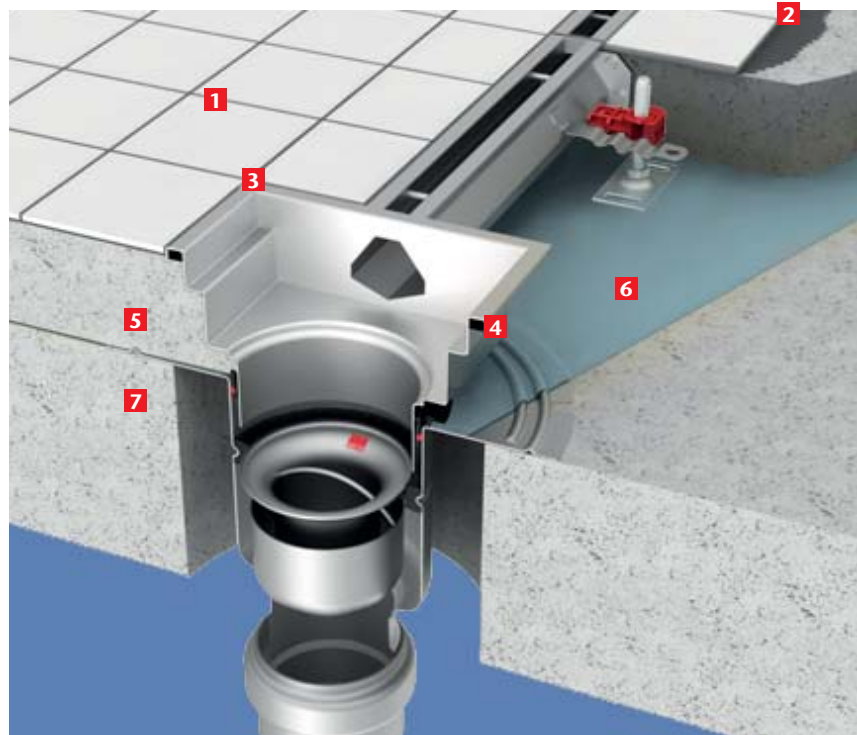

ACO modular slot channel standard type – ACO hygienic gully with mechanical clamping flange (Tiled floor)

- 1** Ceramic tiles
- 2** Tile cement
- 3** Mastic sealant
- 4** Rubber infill
- 5** Floor screed
- 6** Water proof membrane
- 7** Solid concrete floor slab
- 8** Compacted soil

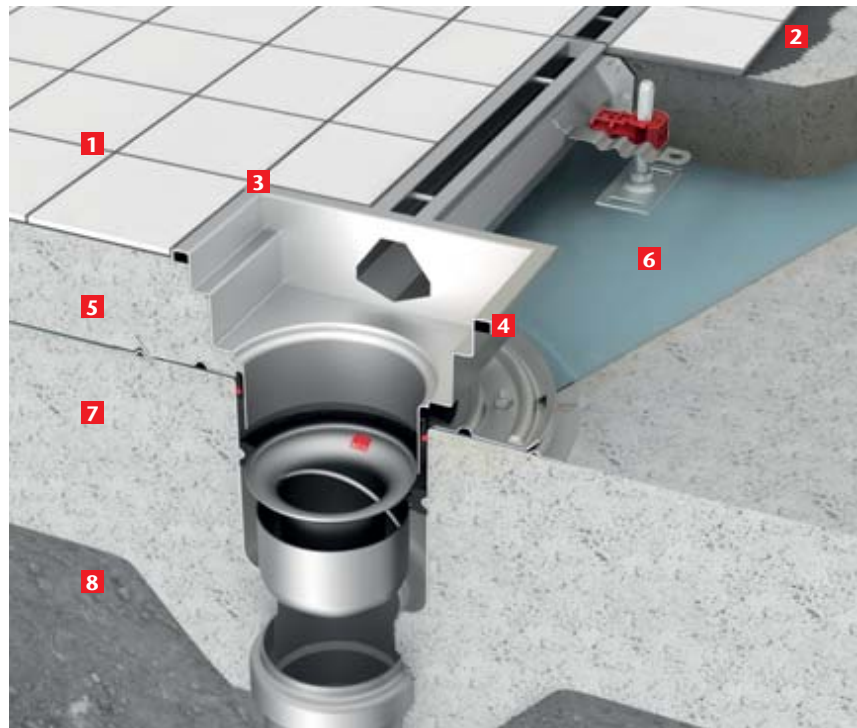

ACO modular slot channel standard type – ACO hygienic gully with location flange (Resin floor)

- 1** Epoxy/resin floor
- 2** Floor screed
- 3** Rubber infill
- 4** Solid concrete floor slab
- 5** Compacted soil

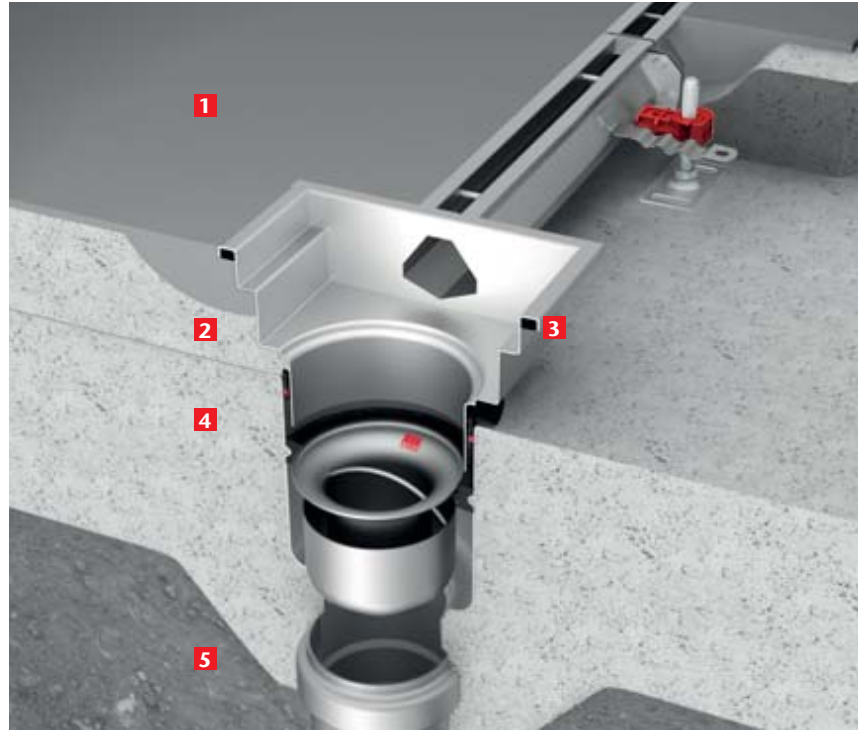

ACO pipe

Generally

The following standards will help designers to select the correct size of pipe system for a particular application: EN 12056: gravity drainage systems inside buildings. EN 752: drain and sewer systems outside buildings. Installation should be in accordance with the manufacturer's recommendations as well as with EN 12056–2, EN 12056–3 and EN 752.

Pipe cutting

If it is necessary to adapt or shorten pipe lengths where tools are used, the cut must be square, clean and chamfered.

Suitable cutters are available from ACO.

These tools are designed to form the edge bevel on the male spigoted end of the pipe. Carbon steel cutting wheels are not suitable.

Vertical pipe stacks

The load applied with a fluid in the pipe is vertically down. Position the highest bracket adjacent to the top inlet of the pipe, then mount brackets at 3 meter spacings. At the bottom of the vertical pipe, use a bracket within 200 mm of the bottom. Fit brackets at each change of pipework is direction or junction points. Pipework should be at least 30 mm from the wall to facilitate maintenance and painting.

Pipe weights

Engineers should be aware of minimum and maximum weights when designing vertical stack and horizontal pipe run systems. Generally, when the pipe is completely full of water, then the vertical deflection of the pipe between brackets should not exceed 1.5 mm. The discretion of the installer should be applied in each instance to ensure that the pipe is adequately supported.

Pipe jointing

The assembly of pipe joints is quick and straightforward requiring only a light application of lubricant available from ACO to the chamfered pipe end. Ensure that the matching ends of the pipes and fittings are clean and free from contamination. Push-fit the pipe end into the socket, but do not push fully into the socket recess so as to allow for thermal expansion within the system.



Horizontal pipe runs

As a guide, use the table below for bracket spacing on horizontal pipes.

Pipe diameter bracket spacing

Pipe ø [mm]	Length [m]
40	2.0
50	2.0
75	2.3
110	2.5
125	3.0
200	3.0
250	3.0

Recommended distances; for installation follow your local standards.



Horizontal pipework should be supported by pipe brackets in 3 meter intervals maximum. One bracket should be within 300 mm of the pipe joint and the other approximately at the midpoint of the pipe length, but not more than 3 metres from the next bracket (depending on the pipe diameter—refer to the upper table).

Additional brackets should be used at changes of direction and at junction points immediately downstream of the fitting. Horizontal pipe runs may be installed at a fall of 1 in 50 and feeder connections should be achieved using 45° branches.

Where long pipe runs occur i.e. greater than 15 meters, a fixing arm should be attached to the bracket to prevent pendulum movement within the system.

Below ground installation

Back-filling

Back-filling around the pipe can only start when the position of the pipe has been checked and approved.

Compression

Care should be taken to avoid distortion of both the pipe run and the pipe itself during back-filling and compaction. Avoid tipping back-fill material directly onto the pipe system. If mechanical compaction is used, the weight and resultant compressive force must be taken into account to avoid distortion. Back-fill materials should be compacted to a minimum of 93%.

Filling in the excavation

Soil from the excavation can be used for filling, but larger stones and blocks should not be used. Compression of the filling material outside reinforced areas is not necessary if the settling will not cause problems or damage.

Local standards

It is recommended to install pipes according to local standards.



ACO protective covers

Description

Product benefits

- Protection from building material debris
- Eliminates cleaning of drainage after installation
- Prevents injuries on worksite
- Certified according to EN 12811-1 for scaffolding load class 3
- Eco friendly and easily disposable

ACO protective covers made from OSB are available for:

- All ACO hygienic gullies and ACO hygienic box channels, standard, semi-standard and customized
- ACO vinyl box channels, standard, semi-standard and customized
- Gully tops on ACO slot channels, semi-standard and customized

Order information:

- For standard articles, add _C at the end of product article number (example: 111111_C)
- For semi-standard and customized articles, specify this option in the order process



Load area	Maximum load capacity	Maximum pressure
200 x 200 mm	max. 100 kg	max. 2.5 N/cm ²
500 x 500 mm	max. 150 kg	max. 0.6 N/cm ²
1000 x 1000 mm	max. 200 kg	max. 0.2 N/cm ²

Classification according to EN 12811-1 for scaffolding load class 3

Notes:

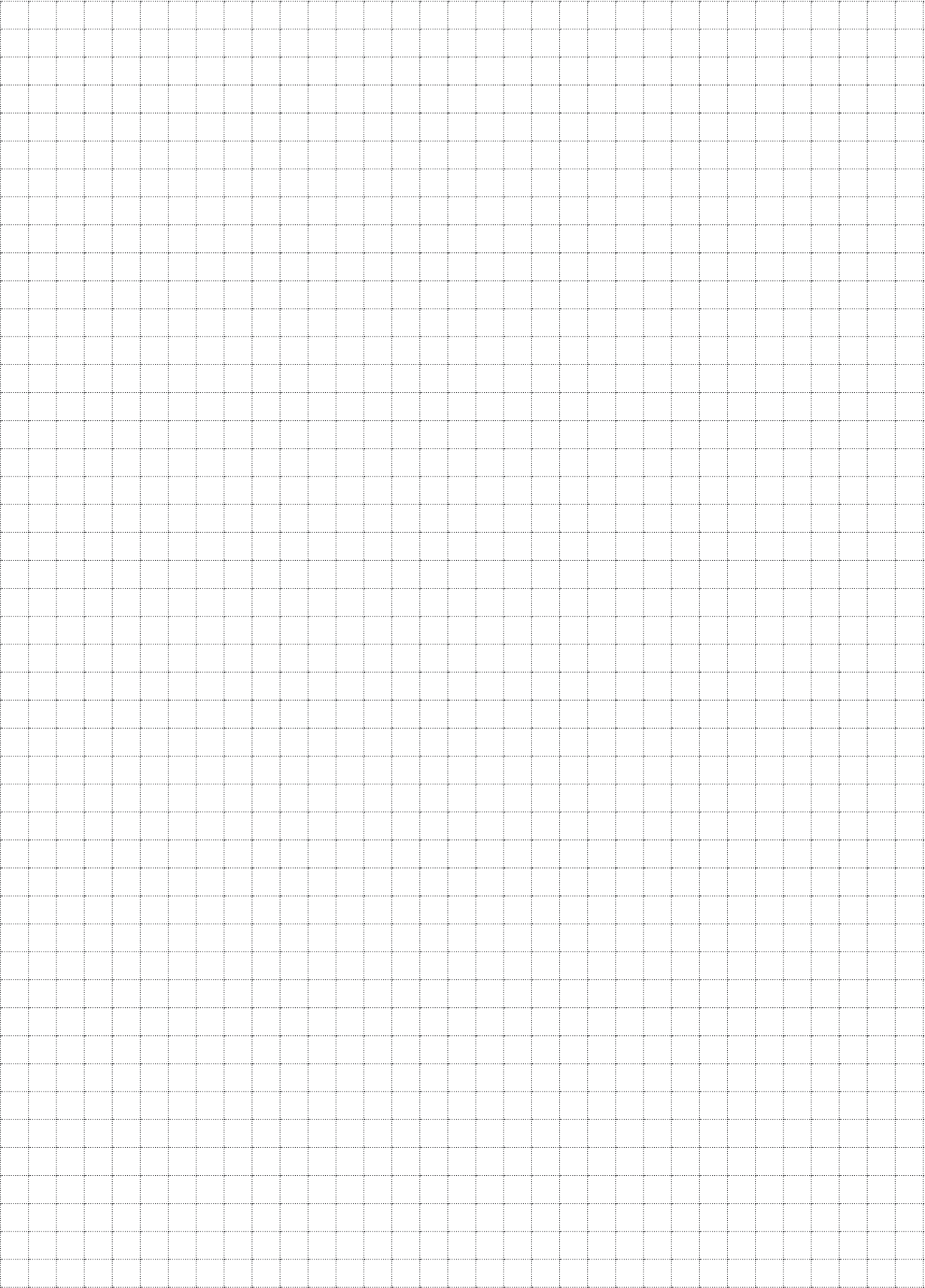

Resistance of Material

1 = Very good service to operating limit of material

2 = Moderate service

3 = Limited or variable service

4 = Unsatisfactory

	AISI 316 Stainless	AISI 304 Stainless	EPDM	NBR	FPM	TPEV
Acetone	1	1	1	4	4	1
Acetic acid (diluted) 30%	1	1	1	2	2	1
Acetic acid 100%	1	1	1	3	3	1
Acetic acid anhydride	1	1	2	3	4	2
Aluminium chloride	4	4	1	1	1	1
Aluminium sulfate	1	4	1	1	1	1
Ammonium carbonate	1	1	1	4	2	1
Ammonium chloride	2	3	1	1	1	1
Ammonium hydroxide	1	1	1	4	2	1
Amyl chloride	1	1	4	4	1	4
Anilin	1	1	2	4	3	1
Anilin hydrochloride	4	4	2	2	2	2
Barium chloride	2	2	1	1	1	1
Barium hydroxide	1	1	1	1	1	1
Benzaldehyde	1	1	1	4	4	1
Benzene	1	1	4	4	1	4
Benzoic acid	1	1	4	4	1	1
Borax	1	1	1	2	1	1
Boric acid	1	1	1	1	1	1
Bromine	4	4	4	4	1	4
Bromine chloride acid	4	4	1	2	1	2
Bromine hydrogen acid	4	4	1	4	1	2
Bromoethylene	1	1	-	-	-	-
Butanol	1	1	4	1	1	3
Butyl acetat	1	1	2	2	4	3
Butyric acid	1	1	2	4	4	3
Calcium bisulfate el sulfite	1	1	4	1	1	1
Calcium chloride	2	2	1	1	1	1
Calcium hydroxide	1	1	1	1	1	1
Calcium hypoklorite	2	3	1	3	1	3
Carbon disulfide	1	1	4	4	1	3
Carbon tetrachloride	1	1	4	3	1	4
Chloracetic acid (mono)	4	4	2	4	4	2
Chloride	4	4	-	-	-	-

Note:

Concentration levels and length of exposure have a direct influence on the resistance of stainless steel to certain chemicals. Each application should therefore be carefully reviewed to determine the suitability of stainless steel.

Assumptions:

Data presented are used as a guide only, for detailed information please contact our Sales/Technical department.

1 = Very good service to operating limit of material

2 = Moderate service

3 = Limited or variable service

4 = Unsatisfactory

	AISI 316 Stainless	AISI 304 Stainless	EPDM	NBR	FPM	TPEV
Chlorilic acid	4	4	1	4	-	3
Chlorine (dry)	1	1	1	2	1	4
Chlorobenzene	1	1	4	4	1	4
Chloroform	2	2	4	4	1	4
Chlorosulfonic acid	2	3	4	4	3	4
Copper chloride	2	2	1	1	1	1
Copper nitrate	1	1	1	1	1	1
Copper sulfate	1	1	1	1	1	1
Ether	1	1	3	4	3	3
Ethyl chloride	1	1	1	1	1	3
Fatty acid	1	1	4	2	1	1
Fluorine (dry)	1	1	-	-	-	-
Fluorine hydrogen acid	4	4	2	4	1	4
Formaldehyde	1	1	1	2	1	1
Formic acid	1	1	1	2	3	2
Furfural	1	1	2	4	4	4
Gallic acid	1	1	2	2	1	2
Hydrochloric acid	4	4	1	4	1	1
Hydrogen peroxide	1	1	3	4	2	3
Iodine (wet)	4	4	2	2	1	2
Lead acetate	1	1	1	2	4	1
Magnesium chloride	2	2	1	1	1	1
Magnesium sulfate	1	1	1	1	1	1
Mercury	1	1	1	1	1	1
Methanol	1	1	1	1	3	1
Methyl chloride	1	1	3	4	1	3
Methylene chloride	2	2	4	4	2	4
Natphalene	1	1	4	4	1	1
Nickel chloride	2	2	1	1	1	1
Nickel sulfate	1	1	1	1	1	1
Nitric acid	3	3	3	4	1	4
Oxalic acid	3	3	1	2	1	2
Perchloric acid	4	4	2	4	1	1
Phorsphor acid	1	1	2	4	1	1
Picric acid	1	1	2	2	1	2
Potassium bromide	1	1	1	1	1	1
Potassium carbonate	1	1	1	2	1	1
Potassium chlorate	1	1	1	1	1	1

Note:

Concentration levels and length of exposure have a direct influence on the resistance of stainless steel to certain chemicals. Each application should therefore be carefully reviewed to determine the suitability of stainless steel.

Assumptions:

Data presented are used as a guide only, for detailed information please contact our Sales/Technical department.

- 1 = Very good service to operating limit of material**
2 = Moderate service
3 = Limited or variable service
4 = Unsatisfactory

	AISI 316 Stainless	AISI 304 Stainless	EPDM	NBR	FPM	TPEV
Potassium cyanide	1	1	1	1	1	1
Potassium hydroxide	1	1	1	2	2	1
Potassium nitrate	1	1	1	1	1	1
Potassium permanganate	1	1	1	3	1	1
Potassium sulfate	1	1	1	1	1	1
Potassium sulfide	1	1	1	1	1	1
Potassiumchloride	2	2	1	1	1	1
Prophylene dichloride	1	1	4	4	1	4
Sal ammoniac	2	3	1	1	1	1
Silver nitrate	1	1	1	2	1	1
Soda (ash)	1	1	1	1	1	1
Sodium acetate	1	1	1	2	4	1
Sodium bicarbonate	1	1	1	1	1	1
Sodium bisulfate	1	3	1	2	1	1
Sodium bisulfite	1	1	1	1	1	1
Sodium bromide	2	2	1	3	1	2
Sodium chlorate	1	1	1	2	1	1
Sodium chloride	4	4	1	1	1	1
Sodium cyanide	1	1	1	1	1	1
Sodium fluoride	1	1	1	1	1	1
Sodium hydroxide	1	1	1	2	2	1
Sodium hypoklorite	4	4	2	2	1	1
Sodium nitrate	1	1	1	2	2	1
Sodium sulfate	1	1	1	1	1	1
Sodium sulfide	1	1	1	1	1	1
Sodium sulfite	1	1	1	1	1	1
Stannicous chloride	2	3	2	1	1	2
Sulfur	1	1	1	4	1	1
Sulfur chloride	1	1	4	3	1	3
Sulfur dioxide	1	2	1	4	1	1
Sulfuric acid	4	4	2	4	1	3
Sulfurous acid	1	3	2	2	1	2
Tionyl chloride	1	1	4	4	1	4
Toluene (toluol)	1	1	4	4	1	4
Trichloroethylene	1	1	4	3	1	4
Turpentine	1	1	4	1	1	4
Xylene (xylol)	1	1	4	4	2	4
Zinc sulfate	1	1	1	1	1	1

Note:

Concentration levels and length of exposure have a direct influence on the resistance of stainless steel to certain chemicals. Each application should therefore be carefully reviewed to determine the suitability of stainless steel.

Assumptions:

Data presented are used as a guide only, for detailed information please contact our Sales/Technical department.

Sealing material information

Sealing material information

EPDM (ethylene propylene diene monomer)

Black sealing rubber ring, which is suitable for most applications where there are no oil or petrol residues in the waste water.

NBR (acryl nitrile-butadiene rubber)

Black sealing rubber ring which is suitable for waste water applications where there are petrol or oil residues. NBR is not resistant to solvents and high temperatures.

FPM (fluoroelastomer) – Viton®

Green sealing rubber ring which is suitable for special applications where oil, solvents and strong acids are present in waste water; and for applications with higher temperatures. Viton® seal has limited resistance to chemicals like acetone, methyl alcohol.

TPEV (thermoplastic elastomer vulkanized)

Sealing rubber with excellent heat resistance, physical and mechanical properties. Suitable for pharmaceutical, medical, food and beverage applications. TPEV has limited resistance in oil or petrol residues in waste water.

Sealing materials

Rubber type	EPDM	NBR	FPM (Viton®)	TPEV
Colour	black	black	green	red
Temperature range	-50 / +130 / +150 °C	-30 / +80 / +100 °C	-20 / +200 / +300 °C	-35 / +120 / +140 °C
Resistance				
Water	excellent	good	good	excellent
Chemicals				
Acids	good	fair	excellent	good
Bases	good	fair	excellent	excellent
Benzene/Petrol	unsatisfied	excellent	excellent	limited
Oils				
ASTM Oil No. 1	unsatisfied	excellent	excellent	limited
ASTM Oil No. 3	unsatisfied	excellent	excellent	limited
Ozone & weather stresses	good	limited	good	good

To be sure of suitability for special applications please consult exact seal material features within ACO installation guide.

Every ACO product supports
the ACO system chain



-
- ACO gully
 - ACO channel
 - ACO pipe
-

ACO Industries k.s.

Havlíčková 260
582 22 Přebyslav
Czech Republic

www.buildingdrainage.aco

All reasonable care has been taken in compiling the information in this document. All recommendations and suggestions on the use of ACO products are made without guarantee since the conditions of use are beyond the control of the Company. It is the customer's responsibility to ensure that each product is fit for its intended purpose and that the actual conditions of use are suitable. This brochure and any advice is provided free of charge and accordingly on terms that no liability (including liability for negligence) will attach the Company or its servants or agents arising out of or in connection with or in relation to this brochure or any such advice. Any goods supplied by the Company will be supplied solely upon its standard conditions of sale, copies of which are available on request. The Company's policy of continuous product development and improvement renders specifications liable to modification. Information provided in this brochure is therefore subject to change without prior notification.